

OECD/G20 BASE EROSION AND PROFIT SHIFTING PROJECT

Tax Challenges Arising from the Digitalisation of the Economy Global Anti-Base Erosion Model Rules (Pillar Two)

INCLUSIVE FRAMEWORK ON BEPS



OECD/G20 Base Erosion and Profit Shifting Project

**Tax Challenges Arising from the
Digitalisation of the Economy – Global
Anti-Base Erosion Model Rules
(Pillar Two)**

Inclusive Framework on BEPS

This document and any map included herein are without prejudice to the status of or sovereignty over any territory, to the delimitation of international frontiers and boundaries and to the name of any territory, city or area.

This document was approved by the OECD/G20 Inclusive Framework on BEPS on 14 December 2021 and prepared for publication by the OECD Secretariat.

Please cite this document as:

OECD (2021), *Tax Challenges Arising from the Digitalisation of the Economy – Global Anti-Base Erosion Model Rules (Pillar Two): Inclusive Framework on BEPS*, OECD, Paris, <https://www.oecd.org/tax/beps/tax-challenges-arising-from-the-digitalisation-of-the-economy-global-anti-base-erosion-model-rules-pillar-two.htm>.

Photo credits: Cover © ninog – Fotolia.com.

© OECD 2021

The use of this work, whether digital or print, is governed by the Terms and Conditions to be found at www.oecd.org/termsandconditions

Foreword

Digitalisation and globalisation have had a profound impact on economies and the lives of people around the world, and this impact has only accelerated in the 21st century. These changes have brought with them challenges to the rules for taxing international business income, which have prevailed for more than a hundred years and created opportunities for base erosion and profit shifting (BEPS), requiring bold moves by policy makers to restore confidence in the system and ensure that profits are taxed where economic activities take place and value is created.

In 2013, the OECD ramped up efforts to address these challenges in response to growing public and political concerns about tax avoidance by large multinationals. The OECD and G20 countries joined forces and developed an Action Plan to address BEPS in September 2013. The Action Plan identified 15 actions aimed at introducing coherence in the domestic rules that affect cross-border activities, reinforcing substance requirements in the existing international standards, and improving transparency as well as certainty.

After two years of work, measures in response to the 15 actions, including those published in an interim form in 2014, were consolidated into a comprehensive package and delivered to G20 Leaders in November 2015. The BEPS package represents the first substantial renovation of the international tax rules in almost a century. As the BEPS measures are implemented, it is expected that profits will be reported where the economic activities that generate them are carried out and where value is created. BEPS planning strategies that rely on outdated rules or on poorly co-ordinated domestic measures will be rendered ineffective.

OECD and G20 countries also agreed to continue to work together to ensure a consistent and co-ordinated implementation of the BEPS recommendations and to make the project more inclusive. As a result, they created the OECD/G20 Inclusive Framework on BEPS (Inclusive Framework), bringing all interested and committed countries and jurisdictions on an equal footing in the Committee on Fiscal Affairs and its subsidiary bodies. With over 140 members, the Inclusive Framework monitors and peer reviews the implementation of the minimum standards and is completing the work on standard setting to address BEPS issues. In addition to its members, other international organisations and regional tax bodies are involved in the work of the Inclusive Framework, which also consults business and the civil society on its different work streams.

Although implementation of the BEPS package is dramatically changing the international tax landscape and improving the fairness of tax systems, one of the key outstanding BEPS issues – to address the tax challenges arising from the digitalisation of the economy – remained unresolved. In a major step forward on 8 October 2021, over 135 Inclusive Framework members, representing more than 95% of global GDP, joined a two-pillar solution to reform the international taxation rules and ensure that multinational enterprises pay a fair share of tax wherever they operate and generate profits in today's digitalised and globalised world economy. The implementation of these new rules is envisaged by 2023.

This report was approved by the Inclusive Framework on 14 December 2021 and prepared for publication by the OECD Secretariat.

Table of contents

| | |
|--|-----------|
| Foreword | 3 |
| Abbreviations and acronyms | 6 |
| Executive summary | 7 |
| 1 Scope | 8 |
| Article 1.1. Scope of GloBE Rules | 8 |
| Article 1.2. MNE Group and Group | 8 |
| Article 1.3. Constituent Entity | 9 |
| Article 1.4. Ultimate Parent Entity | 9 |
| Article 1.5. Excluded Entity | 9 |
| 2 Charging Provisions | 11 |
| Article 2.1. Application of the IIR | 11 |
| Article 2.2. Allocation of Top-Up Tax under the IIR | 12 |
| Article 2.3. IIR Offset Mechanism | 12 |
| Article 2.4. Application of the UTPR | 12 |
| Article 2.5. UTPR Top-up Tax Amount | 13 |
| Article 2.6. Allocation of Top-Up Tax for the UTPR | 13 |
| 3 Computation of GloBE Income or Loss | 15 |
| Article 3.1. Financial Accounts | 15 |
| Article 3.2. Adjustments to determine GloBE Income or Loss | 15 |
| Article 3.3. International Shipping Income exclusion | 18 |
| Article 3.4. Allocation of Income or Loss between a Main Entity and a Permanent Establishment | 19 |
| Article 3.5. Allocation of Income or Loss from a Flow-through Entity | 20 |
| 4 Computation of Adjusted Covered Taxes | 22 |
| Article 4.1. Adjusted Covered Taxes | 22 |
| Article 4.2. Definition of Covered Taxes | 23 |
| Article 4.3. Allocation of Covered Taxes from one Constituent Entity to another Constituent Entity | 24 |
| Article 4.4. Mechanism to address temporary differences | 25 |
| Article 4.5. The GloBE Loss Election | 26 |
| Article 4.6. Post-filing Adjustments and Tax Rate Changes | 27 |

| | |
|--|-----------|
| 5 Computation of Effective Tax Rate and Top-up Tax | 28 |
| Article 5.1. Determination of Effective Tax Rate | 28 |
| Article 5.2. Top-up Tax | 29 |
| Article 5.3. Substance-based Income Exclusion | 30 |
| Article 5.4. Additional Current Top-up Tax | 31 |
| Article 5.5. De minimis exclusion | 32 |
| Article 5.6. Minority-Owned Constituent Entities | 33 |
| 6 Corporate Restructurings and Holding Structures | 34 |
| Article 6.1. Application of Consolidated Revenue Threshold to Group Mergers and Demergers | 34 |
| Article 6.2. Constituent Entities joining and leaving an MNE Group | 35 |
| Article 6.3. Transfer of Assets and Liabilities | 36 |
| Article 6.4. Joint Ventures | 37 |
| Article 6.5. Multi-Parented MNE Groups | 37 |
| 7 Tax neutrality and distribution regimes | 39 |
| Article 7.1. Ultimate Parent Entity that is a Flow-through Entity | 39 |
| Article 7.2. Ultimate Parent Entity subject to Deductible Dividend Regime | 40 |
| Article 7.3. Eligible Distribution Tax Systems | 41 |
| Article 7.4. Effective Tax Rate Computation for Investment Entities | 42 |
| Article 7.5. Investment Entity Tax Transparency Election | 43 |
| Article 7.6. Taxable Distribution Method Election | 43 |
| 8 Administration | 46 |
| Article 8.1. Filing obligation | 46 |
| Article 8.2. Safe Harbours | 47 |
| Article 8.3. Administrative Guidance | 48 |
| 9 Transition rules | 49 |
| Article 9.1. Tax Attributes Upon Transition | 49 |
| Article 9.2. Transitional relief for the Substance-based Income Exclusion | 49 |
| Article 9.3. Exclusion from the UTPR of MNE Groups in the initial phase of their international activity | 50 |
| Article 9.4. Transitional relief for filing obligations | 51 |
| 10 Definitions | 52 |
| Article 10.1. Defined Terms | 52 |
| Article 10.2. Definitions of Flow-through Entity, Tax Transparent Entity, Reverse Hybrid Entity, and Hybrid Entity | 67 |
| Article 10.3. Location of an Entity and a Permanent Establishment | 67 |

Abbreviations and acronyms

| | |
|-------|--|
| CE | Constituent Entity |
| ETR | Effective Tax Rate |
| GloBE | Global Anti-Base Erosion |
| IFRS | International Financial Reporting Standards |
| JV | Joint Venture |
| MNE | Multinational enterprise |
| OECD | Organisation for Economic Co-operation and Development |
| UPE | Ultimate Parent Entity |

Executive summary

The Global Anti-Base Erosion (GloBE) Rules provide for a co-ordinated system of taxation intended to ensure large multinational enterprise (MNE) groups pay a minimum level of tax on the income arising in each of the jurisdictions where they operate. It does so by imposing a top-up tax on profits arising in a jurisdiction whenever the effective tax rate, determined on a jurisdictional basis, is below the minimum rate.

- Chapter 1 defines the scope of the GloBE Rules.
- Chapter 2 determines the constituent entities in the group that are liable for any top-up tax and the portion of any top-up tax charged to any such entity.
- Chapters 3 and 4 set out the components of the effective tax rate calculation under the GloBE Rules. Chapter 3 determines the income (or loss) for the period for each constituent entity in the MNE Group and Chapter 4 then identifies the taxes attributable to such income
- Chapter 5 aggregates the income and taxes of all constituent entities located in the same jurisdiction to determine the effective tax rate for that jurisdiction. If the effective tax rate is below the minimum rate, the difference results in a top-up tax percentage which is applied to the jurisdictional income to determine the total amount of top-up tax. The top-up tax is pro-rated amongst the constituent entities located in that jurisdiction and then charged to the constituent entities liable for any top-up tax in accordance with Chapter 2. Chapter 5 also includes an elective substance-based income exclusion that may reduce the amount of profits subject to any top-up tax.
- Chapter 6 contains rules relating to acquisitions, disposals and joint ventures.
- Chapter 7 deals with the application of the GloBE Rules to certain tax neutrality and other distribution regimes.
- Chapter 8 covers administrative aspects of the GloBE Rules including information filing requirements as well as the application of any safe-harbours.
- Chapter 9 sets out certain transitional rules.
- Chapter 10 sets out defined terms used in the GloBE Rules.

The GloBE Rules apply a minimum rate on a jurisdictional basis. In that context, the OECD/G20 Inclusive Framework on BEPS agreed, in its 8 October 2021 statement, that consideration will be given to the conditions under which the US Global Intangible Low-Taxed Income (GILTI) regime will co-exist with the GloBE Rules, to ensure a level playing field.

1 Scope

Operation of the rules in this chapter

Chapter 1 defines the scope of the rules.

- Article 1.1 determines which MNE Groups and Group Entities are subject to the GloBE Rules.
- Article 1.2 to Article 1.4 set out a number of key definitions that are used to determine when an Entity or collection of Entities constitutes a Group and when that Group qualifies as an MNE Group.
- Article 1.5 specifies those Entities that are Excluded Entities and therefore outside the operative provisions of the GloBE Rules.

Article 1.1. Scope of GloBE Rules

1.1.1. The GloBE Rules apply to Constituent Entities that are members of an MNE Group that has annual revenue of EUR 750 million or more in the Consolidated Financial Statements of the Ultimate Parent Entity (UPE) in at least two of the four Fiscal Years immediately preceding the tested Fiscal Year. Further rules are set out in Article 6.1 which modify the application of the consolidated revenue threshold in certain cases.

1.1.2. If one or more of the Fiscal Years of the MNE Group taken into account for purposes of Article 1.1.1 is of a period other than 12 months, for each of those Fiscal Years the EUR 750 million threshold is adjusted proportionally to correspond with the length of the relevant Fiscal Year.

1.1.3. Entities that are Excluded Entities are not subject to the GloBE Rules.

Article 1.2. MNE Group and Group

1.2.1. An MNE Group means any Group that includes at least one Entity or Permanent Establishment that is not located in the jurisdiction of the Ultimate Parent Entity.

1.2.2. A Group means a collection of Entities that are related through ownership or control such that the assets, liabilities, income, expenses and cash flows of those Entities:

- (a) are included in the Consolidated Financial Statements of the Ultimate Parent Entity; or
- (b) are excluded from the Consolidated Financial Statements of the Ultimate Parent Entity solely on size or materiality grounds, or on the grounds that the Entity is held for sale.

1.2.3. A Group also means an Entity that is located in one jurisdiction and has one or more Permanent Establishments located in other jurisdictions provided that the Entity is not a part of another Group described in Article 1.2.2.

Article 1.3. Constituent Entity

- 1.3.1. A Constituent Entity is:
- (a) any Entity that is included in a Group; and
 - (b) any Permanent Establishment of a Main Entity that is within paragraph (a).
- 1.3.2. A Permanent Establishment that is a Constituent Entity under paragraph (b) above shall be treated as separate from the Main Entity and any other Permanent Establishment of that Main Entity.
- 1.3.3. A Constituent Entity does not include an Entity that is an Excluded Entity.

Article 1.4. Ultimate Parent Entity

- 1.4.1. Ultimate Parent Entity means either:
- (a) an Entity that:
 - i. owns directly or indirectly a Controlling Interest in any other Entity; and
 - ii. is not owned, with a Controlling Interest, directly or indirectly by another Entity; or
 - (b) the Main Entity of a Group that is within Article 1.2.3.

Article 1.5. Excluded Entity

- 1.5.1. An Excluded Entity is an Entity that is:
- (a) a Governmental Entity;
 - (b) an International Organisation;
 - (c) a Non-profit Organisation;
 - (d) a Pension Fund;
 - (e) an Investment Fund that is an Ultimate Parent Entity; or
 - (f) a Real Estate Investment Vehicle that is an Ultimate Parent Entity.
- 1.5.2. An Excluded Entity is also an Entity:
- (a) where at least 95% of the value of the Entity is owned (directly or through a chain of Excluded Entities) by one or more Excluded Entities referred to in Article 1.5.1 (other than a Pension Services Entity) and where that Entity:
 - i. operates exclusively or almost exclusively to hold assets or invest funds for the benefit of the Excluded Entity or Entities; or
 - ii. only carries out activities that are ancillary to those carried out by the Excluded Entity or Entities; or
 - (b) where at least 85% of the value of the Entity is owned (directly or through a chain of Excluded Entities), by one or more Excluded Entities referred to in Article 1.5.1 (other than a Pension Services Entity) provided that substantially all of the Entity's income is Excluded Dividends or Excluded Equity Gain or Loss that is excluded from the computation of GloBE Income or Loss in accordance with Articles 3.2.1(b) or (c).

1.5.3. A Filing Constituent Entity may elect not to treat an Entity as an Excluded Entity under Article 1.5.2. An election under this Article is a Five-Year Election.

2 Charging Provisions

Operation of the rules in this chapter

Under this chapter, the amount of Top-Up Tax charged to a Parent Entity or to the Constituent Entities located in a UTPR Jurisdiction is determined:

- by attributing the Top-Up Tax of each Low-Taxed Constituent Entity determined under the rules in Chapter 5 to the Parent Entity under the IIR in accordance with Article 2.1 to Article 2.3; and then
- by allocating the residual Top-Up Tax, if any, to UTPR Jurisdictions in accordance with Article 2.4 to Article 2.6.

Article 2.1. Application of the IIR

2.1.1. A Constituent Entity, that is the Ultimate Parent Entity of an MNE Group, located in [insert name of implementing-jurisdiction] that owns (directly or indirectly) an Ownership Interest in a Low-Taxed Constituent Entity at any time during the Fiscal Year shall pay a tax in an amount equal to its Allocable Share of the Top-Up Tax of that Low-Taxed Constituent Entity for the Fiscal Year.

2.1.2. An Intermediate Parent Entity of an MNE Group located in [insert name of implementing-jurisdiction] that owns (directly or indirectly) an Ownership Interest in a Low-Taxed Constituent Entity at any time during a Fiscal Year shall pay a tax in an amount equal to its Allocable Share of the Top-Up Tax of that Low-Taxed Constituent Entity for the Fiscal Year.

2.1.3. Article 2.1.2 shall not apply if:

- (a) the Ultimate Parent Entity of the MNE Group is required to apply a Qualified IIR for that Fiscal Year; or
- (b) another Intermediate Parent Entity that owns (directly or indirectly) a Controlling Interest in the Intermediate Parent Entity is required to apply a Qualified IIR for that Fiscal Year.

2.1.4. Notwithstanding Articles 2.1.1 to 2.1.3, a Partially-Owned Parent Entity located in [insert name of implementing-jurisdiction] that owns (directly or indirectly) an Ownership Interest in a Low-Taxed Constituent Entity at any time during the Fiscal Year shall pay a tax in an amount equal to its Allocable Share of the Top-up Tax of that Low-Taxed Constituent Entity for the Fiscal Year.

2.1.5. Article 2.1.4 shall not apply if the Partially-Owned Parent Entity is wholly owned (directly or indirectly) by another Partially-Owned Parent Entity that is required to apply a Qualified IIR for that Fiscal Year.

2.1.6. A Parent Entity located in [insert name of implementing-jurisdiction] shall apply the provisions of Articles 2.1.1 to 2.1.5 with respect to a Low-Taxed Constituent Entity that is not located in [insert name of implementing-jurisdiction].

Article 2.2. Allocation of Top-Up Tax under the IIR

2.2.1. A Parent Entity's Allocable Share of the Top-up Tax of a Low-Taxed Constituent Entity is an amount equal to the Top-up Tax of the Low-Taxed Constituent Entity as calculated under Chapter 5 multiplied by the Parent Entity's Inclusion Ratio for the Low-Taxed Constituent Entity for the Fiscal Year.

2.2.2. A Parent Entity's Inclusion Ratio for a Low-Taxed Constituent Entity for a Fiscal Year is the ratio of (a) the GloBE Income of the Low-Taxed Constituent Entity for the Fiscal Year, reduced by the amount of such income attributable to Ownership Interests held by other owners, to (b) the GloBE Income of the Low-Taxed Constituent Entity for the Fiscal Year.

2.2.3. The amount of GloBE Income attributable to Ownership Interests in a Low-Taxed Constituent Entity held by other owners is the amount that would have been treated as attributable to such owners under the principles of the Acceptable Financial Accounting Standard used in the Ultimate Parent Entity's Consolidated Financial Statements if the Low-Taxed Constituent Entity's net income were equal to its GloBE Income and:

- (a) the Parent Entity had prepared Consolidated Financial Statements in accordance with that accounting standard (the hypothetical Consolidated Financial Statements);
- (b) the Parent Entity owned a Controlling Interest in the Low-Taxed Constituent Entity such that all of the income and expenses of the Low-Taxed Constituent Entity were consolidated on a line-by-line basis with those of the Parent Entity in the hypothetical Consolidated Financial Statements;
- (c) all of the Low-Taxed Constituent Entity's GloBE Income were attributable to transactions with persons that are not Group Entities; and
- (d) all Ownership Interests not directly or indirectly held by the Parent Entity were held by persons other than Group Entities.

2.2.4. In the case of a Flow-through Entity, GloBE Income under this Article shall not include any income allocated, pursuant to Article 3.5.3, to an owner that is not a Group Entity.

Article 2.3. IIR Offset Mechanism

2.3.1. A Parent Entity that owns an Ownership Interest in a Low-Taxed Constituent Entity indirectly through an Intermediate Parent Entity or a Partially-Owned Parent Entity that is not eligible for an exclusion from the IIR under Article 2.1.3 or 2.1.5 shall reduce its allocable share of a Top-up Tax of the Low-Taxed Constituent Entity in accordance with Article 2.3.2.

2.3.2. The reduction in Article 2.3.1 will be an amount equal to the portion of the Parent Entity's Allocable Share of the Top-up Tax that is brought into charge by the Intermediate Parent Entity or the Partially-Owned Parent Entity under a Qualified IIR.

Article 2.4. Application of the UTPR

2.4.1. Constituent Entities of an MNE Group located in [insert name of implementing-Jurisdiction] shall be denied a deduction (or required to make an equivalent adjustment under domestic law) in an amount resulting in those Constituent Entities having an additional cash tax expense equal to the UTPR Top-up Tax Amount for the Fiscal Year allocated to that jurisdiction.

2.4.2. The adjustment mentioned in Article 2.4.1 shall apply to the extent possible with respect

to the taxable year in which the Fiscal Year ends. If this adjustment is insufficient to produce an additional cash tax expense for this taxable year equal to the UTPR Top-up Tax Amount allocated to [insert name of implementing-Jurisdiction] for the Fiscal Year, the difference shall be carried forward to the extent necessary to the succeeding Fiscal Years and be subject to the adjustment mentioned in Article 2.4.1 to the extent possible for each taxable year.

2.4.3. Article 2.4.1 shall not apply to a Constituent Entity that is an Investment Entity.

Article 2.5. UTPR Top-up Tax Amount

2.5.1. The Total UTPR Top-up Tax Amount for a Fiscal Year shall be equal to the sum of the Top-up Tax calculated for each Low-Taxed Constituent Entity of an MNE Group for that Fiscal Year (determined in accordance with Article 5.2), subject to the adjustments set out in this Article 2.5 and Article 9.3.

2.5.2. The Top-up Tax calculated for a Low-Taxed Constituent Entity that is otherwise taken into account under Article 2.5.1 shall be reduced to zero if all of the Ultimate Parent Entity's Ownership Interests in such Low-Taxed Constituent Entity are held directly or indirectly by one or more Parent Entities that are required to apply a Qualified IIR in the jurisdiction where they are located with respect to that Low-Taxed Constituent Entity for the Fiscal Year.

2.5.3. Where Article 2.5.2 does not apply, the Top-up Tax calculated for a Low-Taxed Constituent Entity that is otherwise taken into account under Article 2.5.1 shall be reduced by a Parent Entity's Allocable Share of the Top-up Tax of that Low-Taxed Constituent Entity that is brought into charge under a Qualified IIR.

Article 2.6. Allocation of Top-Up Tax for the UTPR

2.6.1. Subject to Articles 2.6.2 and 2.6.3, the UTPR Top-up Tax Amount allocated to [insert name of implementing-Jurisdiction] shall be determined by multiplying the Total UTPR Top-up Tax Amount determined in Article 2.5.1 by the jurisdiction's UTPR Percentage. The UTPR Percentage of [insert name of implementing-Jurisdiction] shall be determined each Fiscal Year for each MNE Group as follows:

$$50\% \times \frac{\text{Number of Employees in the jurisdiction}}{\text{Number of Employees in all UTPR jurisdictions}} + 50\% \times \frac{\text{Total value of Tangible Assets in the jurisdiction}}{\text{Total value of Tangible Assets in all UTPR jurisdictions}}$$

Where, for each Fiscal Year:

- (a) the Number of Employees in the jurisdiction is the total Number of Employees of all the Constituent Entities of the MNE Group located in [insert name of implementing-Jurisdiction];
- (b) the Number of Employees in all UTPR Jurisdictions is the total Number of Employees of all the Constituent Entities of the MNE Group located in a jurisdiction that has a Qualified UTPR in force for the Fiscal Year;
- (c) the total value of Tangible Assets in the jurisdiction is the sum of the Net Book Values of Tangible Assets of all the Constituent Entities of the MNE Group located in [insert name of implementing-Jurisdiction];
- (d) the total value of Tangible Assets in all UTPR Jurisdictions is the sum of the Net Book Values of Tangible Assets of all the Constituent Entities of the MNE Group located in a

jurisdiction that has a Qualified UTPR in Force for the Fiscal Year.

2.6.2. For purposes of Article 2.6.1,

- (a) the Number of Employees employed and the Net Book Value of Tangible Assets held by an Investment Entity shall be excluded from the elements of the formula for allocating the Total UTPR Top-up Tax Amount;
- (b) the Number of Employees employed and the Net Book Value of Tangible Assets held by a Flow-through Entity that are not allocated to Permanent Establishments shall be allocated to the Constituent Entities (if any) that are located in the jurisdiction where the Flow-through Entity was created. The Number of Employees employed and the Net Book Value of Tangible Assets held by a Flow-through Entity that are not allocated either to Permanent Establishments or under this provision shall be excluded from the formula for allocating the Total UTPR Top-up Tax Amount.

2.6.3. Notwithstanding Article 2.6.1, the UTPR Percentage of [insert name of implementing-Jurisdiction] for an MNE Group is deemed to be zero for a Fiscal Year as long as the Top-Up Tax Amount allocated to [insert name of implementing-Jurisdiction] in a prior Fiscal Year has not resulted in the Constituent Entities of this MNE Group located in [insert name of implementing-Jurisdiction] having an additional cash tax expense equal, in total, to the UTPR Top-up Tax Amount for that prior Fiscal Year allocated to [insert name of implementing-Jurisdiction]. The Number of Employees and the Tangible Assets of the Constituent Entities of this MNE Group located in a jurisdiction with a UTPR Percentage of zero for a Fiscal Year shall be excluded from the formula provided under Article 2.6.1 for allocating the Total UTPR Top-up Tax Amount for that Fiscal Year.

2.6.4. Article 2.6.3 does not apply for a Fiscal Year if all jurisdictions with a Qualified UTPR in Force for the Fiscal Year have a UTPR Percentage of zero for the MNE Group for that Fiscal Year.

3 Computation of GloBE Income or Loss

Operation of the rules in this chapter

Under this chapter, the amount of GloBE Income or Loss of a Constituent Entity is determined:

- by taking the Financial Accounting Net Income or Loss determined for the Constituent Entity for the Fiscal Year in accordance with Article 3.1; and then
- by adjusting this amount under Article 3.2 to Article 3.5 to arrive at that Entity's GloBE Income or Loss.

Article 3.1. Financial Accounts

3.1.1. The GloBE Income or Loss of each Constituent Entity is the Financial Accounting Net Income or Loss determined for the Constituent Entity for the Fiscal Year adjusted for the items described in Article 3.2 to Article 3.5.

3.1.2. Financial Accounting Net Income or Loss is the net income or loss determined for a Constituent Entity (before any consolidation adjustments eliminating intra-group transactions) in preparing Consolidated Financial Statements of the Ultimate Parent Entity.

3.1.3. If it is not reasonably practicable to determine the Financial Accounting Net Income or Loss for a Constituent Entity based on the accounting standard used in the preparation of Consolidated Financial Statements of the Ultimate Parent Entity, the Financial Accounting Net Income or Loss for the Constituent Entity for the Fiscal Year may be determined using another Acceptable Financial Accounting Standard or an Authorised Financial Accounting Standard if:

- (a) the financial accounts of the Constituent Entity are maintained based on that accounting standard;
- (b) the information contained in the financial accounts is reliable; and
- (c) permanent differences in excess of EUR 1 million that arise from the application of a particular principle or standard to items of income or expense or transactions that differs from the financial standard used in the preparation of the Consolidated Financial Statements of the Ultimate Parent Entity are conformed to the treatment required under the accounting standard used in the Consolidated Financial Statements of the Ultimate Parent Entity.

Article 3.2. Adjustments to determine GloBE Income or Loss

3.2.1. A Constituent Entity's Financial Accounting Net Income or Loss is adjusted for the following items to arrive at that Entity's GloBE Income or Loss:

- (a) Net Taxes Expense;
- (b) Excluded Dividends;
- (c) Excluded Equity Gain or Loss;
- (d) Included Revaluation Method Gain or Loss;
- (e) Gain or loss from disposition of assets and liabilities excluded under Article 6.3;
- (f) Asymmetric Foreign Currency Gains or Losses;
- (g) Policy Disallowed Expenses;
- (h) Prior Period Errors and Changes in Accounting Principles; and
- (i) Accrued Pension Expense.

3.2.2. At the election of the Filing Constituent Entity, a Constituent Entity may substitute the amount allowed as a deduction in the computation of its taxable income in its location for the amount expensed in its financial accounts for a cost or expense of such Constituent Entity that was paid with stock-based compensation. If the stock-based compensation expense arises in connection with an option that expires without exercise, the Constituent Entity must include the total amount previously deducted in the computation of its GloBE Income or Loss for the Fiscal Year in which the option expires. The election is a Five-Year Election and must be applied consistently to the stock-based compensation of all Constituent Entities located in the same jurisdiction for the year in which the election is made and all subsequent Fiscal Years. If the election is made in a Fiscal Year after some of the stock-based compensation of a transaction has been recorded in the financial accounts, the Constituent Entity must include in the computation of its GloBE Income or Loss for that Fiscal Year an amount equal to the excess of the cumulative amount allowed as an expense in the computation of its GloBE Income or Loss in previous Fiscal Years over the cumulative amount that would have been allowed as an expense if the election had been in place in those Fiscal Years. If the election is revoked, the Constituent Entity must include in the computation of its GloBE Income or Loss for the revocation year the amount deducted pursuant to the election that exceeds financial accounting expense accrued in respect of the stock-based compensation that has not been paid.

3.2.3. Any transaction between Constituent Entities located in different jurisdictions that is not recorded in the same amount in the financial accounts of both Constituent Entities or that is not consistent with the Arm's Length Principle must be adjusted so as to be in the same amount and consistent with the Arm's Length Principle. A loss from a sale or other transfer of an asset between two Constituent Entities located in the same jurisdiction that is not recorded consistent with the Arm's Length Principle shall be recomputed based on the Arm's Length Principle if that loss is included in the computation of GloBE Income or Loss. Rules for allocating income or loss between a Main Entity and its Permanent Establishments are found in Article 3.4.

3.2.4. Qualified Refundable Tax Credits shall be treated as income in the computation of GloBE Income or Loss of a Constituent Entity. Non-Qualified Refundable Tax Credits shall not be treated as income in the computation of GloBE Income or Loss of a Constituent Entity.

3.2.5. With respect to assets and liabilities that are subject to fair value or impairment accounting in the Consolidated Financial Statements, a Filing Constituent Entity may elect to determine gains and losses using the realisation principle for purposes of computing GloBE Income. The election is a Five-Year Election and applies to all Constituent Entities located in the jurisdiction to which the election applies. The election applies to all assets and liabilities of such Constituent Entities, unless the Filing Constituent Entity chooses to limit the election to tangible assets of such Constituent Entities or to Constituent Entities that are Investment Entities. Under this election:

- (a) all gains or losses attributable to fair value or impairment accounting with respect to an

asset or liability shall be excluded from the computation of GloBE Income or Loss;

- (b) the carrying value of an asset or liability for purposes of determining gain or loss shall be its carrying value at the later of:
 - (i) the first day of the election year, or
 - (ii) the date the asset was acquired or liability was incurred; and
- (c) if the election is revoked, the GloBE Income or Loss of the Constituent Entities is adjusted by the difference at the beginning of the revocation year between the fair value of the asset or liability and the carrying value of the asset or liability determined pursuant to the election.

3.2.6. Where there is Aggregate Asset Gain in a jurisdiction in a Fiscal Year, the Filing Constituent Entity may make, under this Article 3.2.6, an Annual Election for that jurisdiction to adjust GloBE Income or Loss with respect to each previous Fiscal Year in the Look-back Period in the manner described in paragraphs (b) and (c) and to spread any remaining Adjusted Asset Gain over the Look-back Period in the manner described in paragraph (d). The Effective Tax Rate (ETR) and Top-up Tax, if any, for any previous Fiscal Year must be re-calculated under Article 5.4.1. When an election is made under this Article:

- (a) Covered Taxes with respect to any Net Asset Gain or Net Asset Loss in the Election Year shall be excluded from the computation of Adjusted Covered Taxes.
- (b) The Aggregate Asset Gain in the Election Year shall be carried-back to the earliest Loss Year and set-off ratably against any Net Asset Loss of any Constituent Entity located in that jurisdiction.
- (c) If, for any Loss Year, the Adjusted Asset Gain exceeds the total amount of Net Asset Loss of all Constituent Entities located in that jurisdiction, the Adjusted Asset Gain shall be carried forward to the following Loss Year (if any) and applied ratably against any Net Asset Loss of any Constituent Entity located in that jurisdiction.
- (d) Any Adjusted Asset Gain that remains after the application of paragraphs (b) and (c) shall be allocated evenly to each Fiscal Year in the Look-back Period. The Allocated Asset Gain for the relevant year shall be included in the computation of GloBE Income or Loss for a Constituent Entity located in that jurisdiction in that year in accordance with the following formula:

$$\text{Allocated Asset Gain for relevant year} \\ \times \frac{\text{The specified Constituent Entity's Net Asset Gain in the Election Year}}{\text{The Net Asset Gain of all specified Constituent Entities in the Election Year}}$$

For the purposes of the above formula, a specified Constituent Entity is Constituent Entity that has Net Asset Gain in the Election Year and was located in the jurisdiction in the relevant year. If there is no specified Constituent Entity for a relevant year the Adjusted Asset Gain allocated to that year will be allocated equally to each Constituent Entity in the jurisdiction in that year.

3.2.7. The computation of a Low-Tax Entity's GloBE Income or Loss shall exclude any expense attributable to an Intragroup Financing Arrangement that can reasonably be anticipated, over the expected duration of the arrangement to:

- (a) increase the amount of expenses taken into account in calculating the GloBE Income or Loss of the Low-Tax Entity;
- (b) without resulting in a commensurate increase in the taxable income of the High-Tax Counterparty.

3.2.8. An Ultimate Parent Entity may elect to apply its consolidated accounting treatment to eliminate income, expense, gains, and losses from transactions between Constituent Entities that are located, and included in a tax consolidation group, in the same jurisdiction for purposes of computing each such Constituent Entity's Net GloBE Income or Loss. The election under this Article is a Five-Year Election. Upon making or revoking such election, appropriate adjustments shall be made for GloBE purposes such that there shall not be duplications or omissions of items of GloBE Income or Loss as a result of having made or revoked the election.

3.2.9. An insurance company shall exclude from the computation of GloBE Income or Loss amounts charged to policyholders for Taxes paid by the insurance company in respect of returns to the policy holders. An insurance company shall include in the computation of GloBE Income or Loss any returns to policyholders that are not reflected in Financial Accounting Net Income or Loss to the extent the corresponding increase or decrease in liability to the policyholders is reflected in its Financial Accounting Net Income or Loss.

3.2.10. Amounts recognised as a decrease to the equity of a Constituent Entity attributable to distributions paid or payable in respect of Additional Tier One Capital issued by the Constituent Entity shall be treated as an expense in the computation of its GloBE Income or Loss. Amounts recognised as an increase to the equity of a Constituent Entity attributable to distributions received or receivable in respect of Additional Tier One Capital held by the Constituent Entity shall be included in the computation of its GloBE Income or Loss.

3.2.11. A Constituent Entity's Financial Accounting Net Income or Loss must be adjusted as necessary to reflect the requirements of the relevant provisions of Chapters 6 and 7.

Article 3.3. International Shipping Income exclusion

3.3.1. For an MNE Group that has International Shipping Income, each Constituent Entity's International Shipping Income and Qualified Ancillary International Shipping Income shall be excluded from the computation of its GloBE Income or Loss under Article 3.2 for the jurisdiction in which it is located. Where the computation of a Constituent Entity's International Shipping Income and Qualified Ancillary International Shipping Income results in a loss, the loss shall be excluded from the computation of its GloBE Income or Loss.

3.3.2. International Shipping Income means the net income obtained by a Constituent Entity from:

- (a) the transportation of passengers or cargo by ships that it operates in international traffic, whether the ship is owned, leased or otherwise at the disposal of the Constituent Entity;
- (b) the transportation of passengers or cargo by ships operated in international traffic under slot-chartering arrangements;
- (c) leasing a ship, to be used for the transportation of passengers or cargo in international traffic, on charter fully equipped, crewed and supplied;
- (d) leasing a ship on a bare boat charter basis, for the use of transportation of passengers or cargo in international traffic, to another Constituent Entity;
- (e) the participation in a pool, a joint business or an international operating agency for the transportation of passengers or cargo by ships in international traffic; and
- (f) the sale of a ship used for the transportation of passengers or cargo in international traffic provided that the ship has been held for use by the Constituent Entity for a minimum of one year.

International Shipping Income shall not include net income obtained from the transportation of passengers or cargo by ships via inland waterways within the same jurisdiction.

3.3.3. Qualified Ancillary International Shipping Income means net income obtained by a Constituent Entity from the following activities that are performed primarily in connection with the transportation of passengers or cargo by ships in international traffic:

- (a) leasing a ship on a bare boat charter basis to another shipping enterprise that is not a Constituent Entity, provided that the charter does not exceed three years;
- (b) sale of tickets issued by other shipping enterprises for the domestic leg of an international voyage;
- (c) leasing and short-term storage of containers or detention charges for the late return of containers;
- (d) provision of services to other shipping enterprises by engineers, maintenance staff, cargo handlers, catering staff, and customer services personnel; and
- (e) investment income where the investment that generates the income is made as an integral part of the carrying on the business of operating the ships in international traffic.

3.3.4. The aggregated Qualified Ancillary International Shipping Income of all Constituent Entities located in a jurisdiction shall not exceed 50% of those Constituent Entities' International Shipping Income.

3.3.5. The costs incurred by a Constituent Entity that are directly attributable to its international shipping activities listed in Article 3.3.2 and the costs directly attributable to its qualified ancillary activities listed in Article 3.3.3 shall be deducted from the Constituent Entity's revenues from such activities to compute its International Shipping Income and Qualified Ancillary International Shipping Income. Other costs incurred by a Constituent Entity that are indirectly attributable to a Constituent Entity's international shipping activities and qualified ancillary activities shall be allocated on the basis of the Constituent Entity's revenues from such activities in proportion to its total revenues. All direct and indirect costs attributed to a Constituent Entity's International Shipping Income and Qualified Ancillary International Shipping Income shall be excluded from the computation of its GloBE Income or Loss.

3.3.6. In order for a Constituent Entity's International Shipping Income and Qualified Ancillary International Shipping Income to qualify for the exclusion from its GloBE Income or Loss under this Article, the Constituent Entity must demonstrate that the strategic or commercial management of all ships concerned is effectively carried on from within the jurisdiction where the Constituent Entity is located.

Article 3.4. Allocation of Income or Loss between a Main Entity and a Permanent Establishment

3.4.1. The Financial Accounting Net Income or Loss of a Constituent Entity that is a Permanent Establishment in accordance with paragraphs (a), (b) and (c) of the definition in Article 10.1 is the net income or loss reflected in the separate financial accounts of the Permanent Establishment. If the Permanent Establishment does not have separate financial accounts, then the Financial Accounting Net Income or Loss is the amount that would have been reflected in its separate financial accounts if prepared on a standalone basis and in accordance with the accounting standard used in the preparation of the Consolidated Financial Accounts of the Ultimate Parent Entity.

3.4.2. The Financial Accounting Net Income or Loss of a Permanent Establishment referred to

in Article 3.4.1 shall be adjusted, if necessary:

- (a) in the case of a Permanent Establishment as defined by paragraphs (a) and (b) of the definition in Article 10.1, to reflect only the amounts and items of income and expense that are attributable to the Permanent Establishment in accordance with the applicable Tax Treaty or domestic law of the jurisdiction where it is located regardless of the amount of income subject to tax and the amount of deductible expenses in that jurisdiction;
- (b) in the case of a Permanent Establishment as defined by paragraph (c) of the definition in Article 10.1, to reflect only the amounts and items of income and expense that would have been attributed to it in accordance with Article 7 of the OECD Model Tax Convention.

3.4.3. In case of a Constituent Entity that is a Permanent Establishment in accordance with paragraph (d) of the definition in Article 10.1, its income used for computing Financial Accounting Net Income or Loss is the income being exempted in the jurisdiction where the Main Entity is located and attributable to the operations conducted outside that jurisdiction. The expenses used for computing Financial Accounting Net Income or Loss are those that are not deducted for taxable purposes in the jurisdiction where the Main Entity is located and that are attributable to such operations.

3.4.4. The Financial Accounting Net Income or Loss of a Permanent Establishment is not taken into account in determining the GloBE Income or Loss of the Main Entity, except as provided in Article 3.4.5.

3.4.5. A GloBE Loss of a Permanent Establishment shall be treated as an expense of the Main Entity (and not of the Permanent Establishment) for purposes of computing its GloBE Income or Loss to the extent that the loss of the Permanent Establishment is treated as an expense in the computation of the domestic taxable income of such Main Entity and is not set off against an item of income that is subject to tax under the laws of both the jurisdiction of the Main Entity and the jurisdiction of the Permanent Establishment. GloBE Income subsequently arising in the Permanent Establishment shall be treated as GloBE Income of the Main Entity (and not the Permanent Establishment) up to the amount of the GloBE Loss that previously was treated as an expense for purposes of computing the GloBE Income or Loss of the Main Entity.

Article 3.5. Allocation of Income or Loss from a Flow-through Entity

3.5.1. The Financial Accounting Net Income or Loss of a Constituent Entity that is a Flow-through Entity is allocated as follows:

- (a) in the case of a Permanent Establishment through which the business of the Entity is wholly or partly carried out, the Financial Accounting Net Income or Loss of the Entity is allocated to that Permanent Establishment in accordance with Article 3.4;
- (b) in the case of a Tax Transparent Entity that is not the Ultimate Parent Entity, any Financial Accounting Net Income or Loss remaining after application of paragraph (a) is allocated to its Constituent Entity-owners in accordance with their Ownership Interests; and
- (c) in the case of a Tax Transparent Entity that is the Ultimate Parent Entity or a Reverse Hybrid Entity, any Financial Accounting Net Income or Loss remaining after application of paragraph (a) is allocated to it.

3.5.2. The rules of Article 3.5.1 shall be applied separately with respect to each Ownership Interest in the Flow-through Entity.

3.5.3. Prior to the application of Article 3.5.1, the Financial Accounting Net Income or Loss of a

Flow-through Entity shall be reduced by the amount allocable to its owners that are not Group Entities and that hold their Ownership Interest in the Flow-through Entity directly or through a Tax Transparent Structure.

3.5.4. Article 3.5.3 does not apply to:

- (a) an Ultimate Parent Entity that is a Flow-through Entity; or
- (b) any Flow-through Entity owned by such an Ultimate Parent Entity (directly or through a Tax Transparent Structure).

The treatment of these Entities is addressed in Article 7.1.

3.5.5. The Financial Accounting Net Income or Loss of a Flow-through Entity is reduced by the amount that is allocated to another Constituent Entity.

4 Computation of Adjusted Covered Taxes

Operation of the rules in this chapter

Under this chapter the amount of a Constituent Entity's Covered Taxes, as defined in Article 4.2 is determined

- by taking the current taxes determined for the Constituent Entity for the Fiscal Year in accordance with Article 4.1, adjusted to reflect certain timing differences under Article 4.4 and Article 4.5; by allocating Covered Taxes from one Constituent Entity to another in certain cases under Article 4.3; and
- by taking into account the effect of certain post-filing tax adjustments under Article 4.6.

Article 4.1. Adjusted Covered Taxes

4.1.1. The Adjusted Covered Taxes of a Constituent Entity for the Fiscal Year shall be equal to the current tax expense accrued in its Financial Accounting Net Income or Loss with respect to Covered Taxes for the Fiscal Year adjusted by:

- (a) the net amount of its Additions to Covered Taxes for the Fiscal Year (as determined under Article 4.1.2) and Reductions to Covered Taxes for the Fiscal Year (as determined under Article 4.1.3);
- (b) the Total Deferred Tax Adjustment Amount (as determined under Article 4.4); and
- (c) any increase or decrease in Covered Taxes recorded in equity or Other Comprehensive Income relating to amounts included in the computation of GloBE Income or Loss that will be subject to tax under local tax rules.

4.1.2. The Additions to Covered Taxes of a Constituent Entity for the Fiscal Year is the sum of:

- (a) any amount of Covered Taxes accrued as an expense in the profit before taxation in the financial accounts;
- (b) any amount of GloBE Loss Deferred Tax Asset used under Article 4.5.3;
- (c) any amount of Covered Taxes that is paid in the Fiscal Year and that relates to an uncertain tax position where that amount has been treated for a previous Fiscal Year as a Reduction to Covered Taxes under Article 4.1.3(d); and
- (d) any amount of credit or refund in respect of a Qualified Refundable Tax Credit that is recorded as a reduction to the current tax expense.

4.1.3. The Reductions to Covered Taxes of a Constituent Entity for the Fiscal Year is the sum of:

- (a) the amount of current tax expense with respect to income excluded from the computation of GloBE Income or Loss under Chapter 3;
- (b) any amount of credit or refund in respect of a Non-Qualified Refundable Tax Credit that is not recorded as a reduction to the current tax expense;
- (c) any amount of Covered Taxes refunded or credited, except for any Qualified Refundable Tax Credit, to a Constituent Entity that was not treated as an adjustment to current tax expense in the financial accounts;
- (d) the amount of current tax expense which relates to an uncertain tax position; and
- (e) any amount of current tax expense that is not expected to be paid within three years of the last day of the Fiscal Year.

4.1.4. No amount of Covered Taxes may be taken into account more than once.

4.1.5. In a Fiscal Year in which there is no Net GloBE Income for a jurisdiction, if the Adjusted Covered Taxes for a jurisdiction are less than zero and less than the Expected Adjusted Covered Taxes Amount the Constituent Entities in that jurisdiction shall be treated as having Additional Current Top-up Tax for the jurisdiction under Article 5.4 arising in the current Fiscal Year equal to the difference between these amounts. The Expected Adjusted Covered Taxes Amount is equal to the GloBE Income or Loss for a jurisdiction multiplied by the Minimum Rate.

Article 4.2. Definition of Covered Taxes

4.2.1. Covered Taxes means:

- (a) Taxes recorded in the financial accounts of a Constituent Entity with respect to its income or profits or its share of the income or profits of a Constituent Entity in which it owns an Ownership Interest;
- (b) Taxes on distributed profits, deemed profit distributions, and non-business expenses imposed under an Eligible Distribution Tax System;
- (c) Taxes imposed in lieu of a generally applicable corporate income tax; and
- (d) Taxes levied by reference to retained earnings and corporate equity, including a Tax on multiple components based on income and equity.

4.2.2. Covered Taxes does not include any amount of:

- (a) Top-up Tax accrued by a Parent Entity under a Qualified IIR;
- (b) Top-up Tax accrued by a Constituent Entity under a Qualified Domestic Minimum Top-Up Tax;
- (c) Taxes attributable to an adjustment made by a Constituent Entity as a result of the application of a Qualified UTPR;
- (d) A Disqualified Refundable Imputation Tax;
- (e) Taxes paid by an insurance company in respect of returns to policyholders.

Article 4.3. Allocation of Covered Taxes from one Constituent Entity to another Constituent Entity

4.3.1. Article 4.3.2 applies to the allocation of Covered Taxes in respect of Permanent Establishments, Tax Transparent Entities and Hybrid Entities as well as the allocation of CFC taxes and taxes on distributions from one Constituent Entity to another.

4.3.2. Covered Taxes are allocated from one Constituent Entity to another Constituent Entity as follows:

- (a) the amount of any Covered Taxes included in the financial accounts of a Constituent Entity with respect to GloBE Income or Loss of a Permanent Establishment is allocated to the Permanent Establishment;
- (b) the amount of any Covered Taxes included in the financial accounts of a Tax Transparent Entity with respect to GloBE Income or Loss allocated to a Constituent Entity-owner pursuant to Article 3.5.1(b) is allocated to that Constituent Entity-owner;
- (c) in the case of a Constituent Entity whose Constituent Entity-owners are subject to a Controlled Foreign Company Tax Regime, the amount of any Covered Taxes included in the financial accounts of its direct or indirect Constituent Entity-owners under a Controlled Foreign Company Tax Regime on their share of the Controlled Foreign Company's income are allocated to the Constituent Entity;
- (d) in the case of a Constituent Entity that is a Hybrid Entity the amount of any Covered Taxes included in the financial accounts of a Constituent Entity-owner on income of the Hybrid Entity is allocated to the Hybrid Entity; and
- (e) the amount of any Covered Taxes accrued in the financial accounts of a Constituent Entity's direct Constituent Entity-owners on distributions from the Constituent Entity during the Fiscal Year are allocated to the distributing Constituent Entity.

4.3.3. Covered Taxes allocated to a Constituent Entity pursuant to Article 4.3.2(c) and (d) in respect of Passive Income are included in such Constituent Entity's Adjusted Covered Taxes in an amount equal to the lesser of:

- (a) the Covered Taxes allocated in respect of such Passive Income; or
- (b) the Top-up Tax Percentage for the Constituent Entity's jurisdiction, determined without regard to the Covered Taxes incurred with respect to such Passive Income by the Constituent Entity-owner, multiplied by the amount of the Constituent Entity's Passive Income includible under any Controlled Foreign Company Tax Regime or fiscal transparency rule.

Any Covered Taxes of the Constituent Entity-owner incurred with respect to such Passive Income that remain after the application of this Article shall not be allocated under Article 4.3.2(c) or (d).

4.3.4. Where the GloBE Income of a Permanent Establishment is treated as GloBE Income of the Main Entity pursuant to Article 3.4.5, any Covered Taxes arising in the location of the Permanent Establishment and associated with such income are treated as Covered Taxes of the Main Entity up to an amount not exceeding such income multiplied by the highest corporate tax rate on ordinary income in the jurisdiction where the Main Entity is located.

Article 4.4. Mechanism to address temporary differences

4.4.1. The Total Deferred Tax Adjustment Amount for a Constituent Entity for the Fiscal Year is equal to the deferred tax expense accrued in its financial accounts if the applicable tax rate is below the Minimum Rate or, in any other case, such deferred tax expense recast at the Minimum Rate, with respect to Covered Taxes for the Fiscal Year subject to the adjustments set forth in Articles 4.4.2 and 4.4.3 and the following exclusions:

- (a) The amount of deferred tax expense with respect to items excluded from the computation of GloBE Income or Loss under Chapter 3;
- (b) The amount of deferred tax expense with respect to Disallowed Accruals and Unclaimed Accruals;
- (c) The impact of a valuation adjustment or accounting recognition adjustment with respect to a deferred tax asset;
- (d) The amount of deferred tax expense arising from a re-measurement with respect to a change in the applicable domestic tax rate; and
- (e) The amount of deferred tax expense with respect to the generation and use of tax credits.

4.4.2. The Total Deferred Tax Adjustment Amount is adjusted as follows:

- (a) Increased by the amount of any Disallowed Accrual or Unclaimed Accrual paid during the Fiscal Year;
- (b) Increased by the amount of any Recaptured Deferred Tax Liability determined in a preceding Fiscal Year which has been paid during the Fiscal Year; and
- (c) Reduced by the amount that would be a reduction to the Total Deferred Tax Adjustment Amount due to recognition of a loss deferred tax asset for a current year tax loss, where a loss deferred tax asset has not been recognised because the recognition criteria are not met.

4.4.3. A deferred tax asset that has been recorded at a rate lower than the Minimum Rate may be recast at the Minimum Rate in the Fiscal Year such deferred tax asset is recorded, if the taxpayer can demonstrate that the deferred tax asset is attributable to a GloBE Loss. The Total Deferred Tax Adjustment Amount is reduced by the amount that a deferred tax asset is increased due to being recast under this Article.

4.4.4. To the extent a deferred tax liability, that is not a Recapture Exception Accrual, is taken into account under this Article and such amount is not paid within the five subsequent Fiscal Years, the amount must be recaptured pursuant to this article. The Amount of the Recaptured Deferred Tax Liability determined for the current Fiscal Year shall be treated as a reduction to Covered Taxes in the fifth preceding Fiscal Year and the Effective Tax Rate and Top-up Tax of such Fiscal Year shall be recalculated under the rules of Article 5.4.1. The Recaptured Deferred Tax Liability for the current Fiscal Year is the amount of the increase in a category of deferred tax liability that was included in the Total Deferred Tax Adjustment Amount in the fifth preceding Fiscal Year that has not reversed by the end of the last day of the current Fiscal Year, unless such amount relates to a Recapture Exception Accrual as set forth in Article 4.4.5.

4.4.5. Recapture Exception Accrual means the tax expense accrued attributable to changes in associated deferred tax liabilities, in respect of:

- (a) Cost recovery allowances on tangible assets
- (b) The cost of a licence or similar arrangement from the government for the use of immovable

property or exploitation of natural resources that entails significant investment in tangible assets;

- (c) Research and development expenses;
- (d) De-commissioning and remediation expenses;
- (e) Fair value accounting on unrealised net gains;
- (f) Foreign currency exchange net gains;
- (g) Insurance reserves and insurance policy deferred acquisition costs;
- (h) Gains from the sale of tangible property located in the same jurisdiction as the Constituent Entity that are reinvested in tangible property in the same jurisdiction; and
- (i) Additional amounts accrued as a result of accounting principle changes with respect to categories (a) through (h).

4.4.6. Disallowed Accrual means:

- (a) Any movement in deferred tax expense accrued in the financial accounts of a Constituent Entity which relates to an uncertain tax position; and
- (b) Any movement in deferred tax expense accrued in the financial accounts of a Constituent Entity which relates to distributions from a Constituent Entity.

4.4.7. Unclaimed Accrual means any increase in a deferred tax liability recorded in the financial accounts of a Constituent Entity for a Fiscal Year that is not expected to be paid within the time period set forth in Article 4.4.4 and for which the Filing Constituent Entity makes an Annual Election not to include in Total Deferred Tax Adjustment Amount for such Fiscal Year.

Article 4.5. The GloBE Loss Election

4.5.1. In lieu of applying the rules set forth in Article 4.4, a Filing Constituent Entity may make a GloBE Loss Election for a jurisdiction. When a GloBE Loss Election is made for a jurisdiction, a GloBE Loss Deferred Tax Asset is established in each Fiscal Year in which there is a Net GloBE Loss for the jurisdiction. The GloBE Loss Deferred Tax Asset is equal to the Net GloBE Loss in a Fiscal Year for the jurisdiction multiplied by the Minimum Rate.

4.5.2. The balance of the GloBE Loss Deferred Tax Asset is carried forward to subsequent Fiscal Years, reduced by the amount of GloBE Loss Deferred Tax Asset used in a Fiscal Year.

4.5.3. The GloBE Loss Deferred Tax Asset must be used in any subsequent Fiscal Year in which there is Net GloBE Income for the jurisdiction in an amount equal to the lower of the Net GloBE Income multiplied by the Minimum Rate or the amount of available GloBE Loss Deferred Tax Asset.

4.5.4. If the GloBE Loss Election is subsequently revoked, any remaining GloBE Loss Deferred Tax Asset is reduced to zero, effective as of the first day of the first Fiscal Year in which the GloBE Loss Election is no longer applicable.

4.5.5. The GloBE Loss Election must be filed with the first GloBE Information Return of the MNE Group that includes the jurisdiction for which the election is made. A GloBE Loss Election cannot be made for a jurisdiction with an Eligible Distribution Tax System as defined in Article 7.3.

4.5.6. A Flow-through Entity that is a UPE of an MNE Group may make a GloBE Loss Election under this Article. When such an election is made, the GloBE Loss Deferred Tax Asset shall be calculated in accordance with Articles 4.5.1 to 4.5.5, however, the GloBE Loss Deferred Tax Asset

shall be calculated with reference to the GloBE Loss of the Flow-through Entity after reduction in accordance with Article 7.1.2.

Article 4.6. Post-filing Adjustments and Tax Rate Changes

4.6.1. An adjustment to a Constituent Entity's liability for Covered Taxes for a previous Fiscal Year recorded in the financial accounts shall be treated as an adjustment to Covered Taxes in the Fiscal Year in which the adjustment is made, unless the adjustment relates to a Fiscal Year in which there is a decrease in Covered Taxes for the jurisdiction. In the case of a decrease in Covered Taxes included in the Constituent Entity's Adjusted Covered Taxes for a previous Fiscal Year, the Effective Tax Rate and Top-up Tax for such Fiscal Year must be recalculated under Article 5.4.1. In the Article 5.4.1 recalculations, the Adjusted Covered Taxes determined for the Fiscal Year shall be reduced by the amount of the decrease in Covered Taxes and GloBE Income determined for the Fiscal Year and any intervening Fiscal Years shall be adjusted as necessary and appropriate. A Filing Constituent Entity may make an Annual Election to treat an immaterial decrease in Covered Taxes as an adjustment to Covered Taxes in the Fiscal Year in which the adjustment is made. An immaterial decrease in Covered Taxes is an aggregate decrease of less than EUR 1 million in the Adjusted Covered Taxes determined for the jurisdiction for a Fiscal Year.

4.6.2. The amount of deferred tax expense resulting from a reduction to the applicable domestic tax rate shall be treated as an adjustment to a Constituent Entity's liability for Covered Taxes claimed under Article 4.1 for a previous Fiscal Year when such reduction results in the application of a rate that is less than the Minimum Rate.

4.6.3. The amount of deferred tax expense, when paid, that has resulted from an increase to the applicable domestic tax rate shall be treated as an adjustment under Article 4.6.1 to a Constituent Entity's liability for Covered Taxes claimed under Article 4.1 for a previous Fiscal Year when such amount was originally recorded at a rate less than the Minimum Rate. This adjustment is limited to an amount that is equal to an increase of deferred tax expense up to such deferred tax expense recast at the Minimum Rate.

4.6.4. If more than EUR 1 million of the amount accrued by a Constituent Entity as current tax expense and included in Adjusted Covered Taxes for a Fiscal Year is not paid within three years of the last day of such year, the Effective Tax Rate and Top-up Tax for the Fiscal Year in which the unpaid amount was claimed as a Covered Tax must be recalculated in accordance with Article 5.4.1 by excluding such unpaid amount from Adjusted Covered Taxes.

5 Computation of Effective Tax Rate and Top-up Tax

Operation of the rules in this chapter

Under this chapter the Top-up Tax of each Low-Taxed Constituent Entity is determined:

- by aggregating each Constituent Entity's GloBE Income or Loss, determined under Chapter 3, and Adjusted Covered Taxes, determined under Chapter 4, with those of other Constituent Entities located in the same jurisdiction to determine an Effective Tax Rate for the jurisdiction;
- by identifying which jurisdiction is a Low-Tax Jurisdiction (i.e. has an Effective Tax Rate that is below the Minimum Rate);
- by computing a jurisdictional Top-Up Tax Percentage for each Low-Tax Jurisdiction;
- by applying the Substance-based Income Exclusion to the Net GloBE Income in the Low-Tax Jurisdiction to determine the Excess Profits in that jurisdiction;
- by multiplying the Top-up Tax percentage by such Excess Profit and reducing the result by the amount of any Qualified Domestic Minimum Top-up Tax to determine the Top-Up Tax for each Low-Tax Jurisdiction; and
- by allocating such Top-up Taxes to the Constituent Entities in the Low-Tax Jurisdiction in proportion to their GloBE Income.

The resulting Top-up Tax of each Low Tax Constituent Entity is then charged to a Parent Entity or to Constituent Entities located in a UTPR Jurisdiction under Chapter 2.

This chapter also includes a *de minimis* exclusion for the Constituent Entities located in the same jurisdiction when their aggregated revenue and income does not exceed certain thresholds. Special rules are provided in Article 5.6 for calculating the ETR in respect of Minority-Owned Constituent Entities.

Article 5.1. Determination of Effective Tax Rate

5.1.1. The Effective Tax Rate of the MNE Group for a jurisdiction with Net GloBE Income shall be calculated for each Fiscal Year. The Effective Tax Rate of the MNE Group for a jurisdiction is equal to the sum of the Adjusted Covered Taxes of each Constituent Entity located in the jurisdiction divided by the Net GloBE Income of the jurisdiction for the Fiscal Year. For purposes of Chapter 5, each Stateless Constituent Entity shall be treated as a single Constituent Entity located in a separate jurisdiction.

5.1.2. The Net GloBE Income of a jurisdiction for a Fiscal Year is the positive amount, if any, computed in accordance with the following formula:

Net GloBE Income = GloBE Income of all Constituent Entities – GloBE Losses of all Constituent Entities

Where:

- (a) the GloBE Income of all Constituent Entities is the sum of the GloBE Income of all Constituent Entities located in the jurisdiction determined in accordance with Chapter 3 for the Fiscal Year; and
- (b) the GloBE Losses of all Constituent Entities is the sum of the GloBE Losses of all Constituent Entities located in the jurisdiction determined in accordance with Chapter 3 for the Fiscal Year.

5.1.3. Adjusted Covered Taxes and GloBE Income or Loss of Constituent Entities that are Investment Entities are excluded from the determination of the Effective Tax Rate in Article 5.1.1 and the determination of Net GloBE Income in Article 5.1.2.

Article 5.2. Top-up Tax

5.2.1. The Top-up Tax Percentage for a jurisdiction for a Fiscal Year shall be the positive percentage point difference, if any, computed in accordance with the following formula:

$$\text{Top up Tax Percentage} = \text{Minimum Rate} - \text{Effective Tax Rate}$$

Where the Effective Tax Rate is the Effective Tax Rate determined in accordance with Article 5.1 for the jurisdiction for the Fiscal Year.

5.2.2. The Excess Profit for the jurisdiction for the Fiscal Year is the positive amount, if any, computed in accordance with the following formula:

$$\text{Excess Profit} = \text{Net GloBE Income} - \text{Substance based Income Exclusion}$$

Where:

- (a) The Net GloBE Income is the Net GloBE Income determined under Article 5.1.2 for the jurisdiction for the Fiscal Year; and
- (b) The Substance-based Income Exclusion is the Substance-based Income Exclusion determined under Article 5.3 for the jurisdiction for the Fiscal Year (if any).

5.2.3. The Jurisdictional Top-up Tax for a jurisdiction for a Fiscal Year is equal to the positive amount, if any, computed in accordance with the following formula:

$$\text{Jurisdictional Top up Tax}$$

$$= (\text{Top up Tax Percentage} \times \text{Excess Profit}) + \text{Additional Current Top up Tax} - \text{Domestic Top up Tax}$$

Where:

- (a) The Top-up Tax Percentage is percentage point difference determined in accordance with Article 5.2.1 for the jurisdiction for the Fiscal Year;
- (b) The Excess Profit is the Excess Profit determined in accordance with Article 5.2.2 for the jurisdiction for the Fiscal Year;
- (c) The Additional Current Top-up Tax is the amount determined, or treated as Additional Current Top-up Tax, under Article 4.1.5 or Article 5.4.1 for the jurisdiction for the Fiscal Year; and
- (d) The Domestic Top-up Tax is the amount payable under a Qualified Domestic Minimum Top-Up Tax of the jurisdiction for the Fiscal Year.

5.2.4. Except as provided in Article 5.4.3, the Top-up Tax of a Constituent Entity shall be determined for each Constituent Entity of a jurisdiction that has GloBE Income determined in accordance with Chapter 3 for the Fiscal Year included in the computation of Net GloBE Income of that jurisdiction in accordance with the following formula:

$$\text{Top up Tax of a CE} = \text{Jurisdictional Top up Tax} \times \frac{\text{GloBE Income of the CE}}{\text{Aggregate GloBE Income of all CEs}}$$

Where:

- (a) The Jurisdictional Top-up Tax is the Top-up Tax determined in accordance with Article 5.2.3 for the jurisdiction for the Fiscal Year;
- (b) The GloBE Income of the CE is the GloBE Income of the Constituent Entity determined in accordance with Article 3.2 for the jurisdiction for the Fiscal Year;
- (c) The aggregate GloBE Income of all CEs is the aggregate GloBE Income of all Constituent Entities that have GloBE Income for the Fiscal Year included in the computation of Net GloBE Income in accordance with Article 5.1.2 for the jurisdiction for the Fiscal Year.

5.2.5. If the Jurisdictional Top-up Tax is attributable to a recalculation under the Article 5.4.1 and the jurisdiction does not have Net GloBE Income for the current Fiscal Year, Top-up Tax shall be allocated using the formula in Article 5.2.4 based on the GloBE Income of the Constituent Entities in the Fiscal Years for which the recalculations under Article 5.4.1 were performed.

Article 5.3. Substance-based Income Exclusion

5.3.1. The Net GloBE Income for the jurisdiction shall be reduced by the Substance-based Income Exclusion for the jurisdiction to determine the Excess Profit for purposes of computing the Top-up Tax under Article 5.2. A Filing Constituent Entity of an MNE Group may make an Annual Election not to apply the Substance-based Income Exclusion for a jurisdiction by not computing the exclusion or claiming it in the computation of Top-up Tax for the jurisdiction in the GloBE Information Return(s) filed for the Fiscal Year.

5.3.2. The Substance-based Income Exclusion amount for a jurisdiction is the sum of the payroll carve-out and the tangible asset carve-out for each Constituent Entity, except for Constituent Entities that are Investment Entities, in that jurisdiction.

5.3.3. The payroll carve-out for a Constituent Entity located in a jurisdiction is equal to 5% of its Eligible Payroll Costs of Eligible Employees that perform activities for the MNE Group in such jurisdiction, except Eligible Payroll costs that are:

- (a) capitalised and included in the carrying value of Eligible Tangible Assets;
- (b) attributable to a Constituent Entity's International Shipping Income and Qualified Ancillary International Shipping Income under Article 3.3.5 that is excluded from the computation of GloBE Income or Loss for the Fiscal Year.

5.3.4. The tangible asset carve-out for a Constituent Entity located in a jurisdiction is equal to 5% of the carrying value of Eligible Tangible Assets located in such jurisdiction. Eligible Tangible Assets means:

- (a) property, plant, and equipment located in that jurisdiction;
- (b) natural resources located in that jurisdiction;
- (c) a lessee's right of use of tangible assets located in that jurisdiction; and

- (d) a licence or similar arrangement from the government for the use of immovable property or exploitation of natural resources that entails significant investment in tangible assets.

For this purpose, the tangible asset carve-out computation shall not include the carrying value of property (including land or buildings) that is held for sale, lease or investment. The tangible asset carve-out computation shall not include the carrying value of tangible assets used in the generation of a Constituent Entity's International Shipping Income and Qualified Ancillary International Shipping Income (i.e. ships and other maritime equipment and infrastructure). The carrying value of tangible assets attributable to a Constituent Entity's excess income over the cap for Qualified Ancillary International Shipping Income under Article 3.3.4 shall be included in the tangible asset carve-out computation.

5.3.5. The computation of carrying value of Eligible Tangible Assets for purposes of Article 5.3.4 shall be based on the average of the carrying value (net of accumulated depreciation, amortisation, or depletion and including any amount attributable to capitalisation of payroll expense) at the beginning and ending of the Reporting Fiscal Year as recorded for the purposes of preparing the Consolidated Financial Statements of the Ultimate Parent Entity.

5.3.6. For purposes of Articles 5.3.3 and 5.3.4, the Eligible Payroll Costs and Eligible Tangible Assets of a Constituent Entity that is a Permanent Establishment are those included in its separate financial accounts as determined by Article 3.4.1 and adjusted in accordance with Article 3.4.2, provided that the Eligible Employees and Eligible Tangible Assets are located in the jurisdiction where the Permanent Establishment is located. The Eligible Payroll Costs and Eligible Tangible Assets of a Permanent Establishment are not taken into account for the Eligible Payroll Costs and Eligible Tangible Assets of the Main Entity. The Eligible Payroll Costs and Eligible Tangible Assets of a Permanent Establishment whose income has been wholly or partly excluded in accordance with Articles 3.5.3 and 7.1.4 are excluded from the Substance-based Income Exclusion computations of the MNE Group in the same proportion.

5.3.7. For purposes of Articles 5.3.3 and 5.3.4, Eligible Payroll Costs and Eligible Tangible Assets of a Flow-through Entity that are not allocated under Article 5.3.6 are allocated as follows:

- (a) if the Financial Accounting Net Income or Loss of the Flow-through Entity has been allocated to the Constituent Entity-owner under Article 3.5.1(b), then the Entity's Eligible Payroll Costs and Eligible Tangible Assets are allocated in the same proportion to the Constituent Entity-owner provided it is located in the jurisdiction where the Eligible Employees and Eligible Tangible Assets are located;
- (b) if the Flow-through Entity is the Ultimate Parent Entity, then Eligible Payroll Costs and Eligible Tangible Assets located in the jurisdiction where the Ultimate Parent Entity is located are allocated to it and reduced in proportion to the income that is excluded under Article 7.1.1; and
- (c) all other Eligible Payroll Costs and Eligible Tangible Assets of the Flow-through Entity are excluded from the Substance-based Income Exclusion computations of the MNE Group.

Article 5.4. Additional Current Top-up Tax

5.4.1. If the Effective Tax Rate and Top-up Tax for a prior Fiscal Year is required or permitted to be recalculated pursuant to an ETR Adjustment Article,

- (a) the Effective Tax Rate and Top-Up Tax for the prior Fiscal Year shall be recalculated in accordance with the rules of Article 5.1 through Article 5.3 after taking into account the adjustments to Adjusted Covered Taxes and GloBE Income or Loss required by the

relevant ETR Adjustment Article; and

- (b) any amount of incremental Top-up Tax resulting from such recalculation shall be treated as Additional Current Top-up Tax under Article 5.2.3 arising in the current Fiscal Year.

5.4.2. If there is Additional Current Top-up Tax attributable to a recalculation under Article 5.4.1 and the jurisdiction does not have Net GloBE Income for the current Fiscal Year, the GloBE Income of each Constituent Entity located in the jurisdiction for purposes of Article 2.2.2 shall be equal to the result of the Top-up Tax allocated to such Entity under Articles 5.2.4 and 5.2.5 divided by the Minimum Rate.

5.4.3. If there is Additional Current Top-up Tax attributable to the operation of Article 4.1.5, the GloBE Income of each Constituent Entity located in the jurisdiction for purposes of Article 2.2.2 shall be equal to the result of the Top-up Tax allocated to such Entity under this Article divided by the Minimum Rate. The amount of Additional Current Top-up Tax allocated to each Constituent Entity for purposes of this Article shall be allocated only to Constituent Entities that record an Adjusted Covered Taxes amount that is less than zero and less than the GloBE Income or Loss of such Constituent Entity multiplied by the Minimum Rate. The allocation shall be made pro-rata based upon the following amount for each of those Constituent Entities:

$$(GloBE\ Income\ or\ Loss\ \times\ Minimum\ Rate) - Adjusted\ Covered\ Taxes$$

5.4.4. If a Constituent Entity is allocated Additional Current top-up Tax pursuant to this Article and Article 5.2.4 such Constituent Entity shall be treated as a Low-Taxed Constituent Entity for the purposes of Chapter 2.

Article 5.5. De minimis exclusion

5.5.1. At the election of the Filing Constituent Entity, and notwithstanding the requirements otherwise provided in Chapter 5, the Top-up Tax for the Constituent Entities located in a jurisdiction shall be deemed to be zero for a Fiscal Year if, for such Fiscal Year:

- (a) the Average GloBE Revenue of such jurisdiction is less than EUR 10 million; and
- (b) the Average GloBE Income or Loss of such jurisdiction is a loss or is less than EUR 1 million.

The election under this Article is an Annual Election.

5.5.2. For purposes of Article 5.5.1, the Average GloBE Revenue (or GloBE Income or Loss) of a jurisdiction is the average of the GloBE Revenue (or GloBE Income or Loss) of the jurisdiction for the current and the two preceding Fiscal Years. If there were no Constituent Entities with GloBE Revenue or GloBE Losses that were located in the jurisdiction in the first or second preceding Fiscal Year, such year or years shall be excluded from the calculation of the Average GloBE Revenue and the Average GloBE Income or Loss of the relevant jurisdiction.

5.5.3. For purposes of Article 5.5.2:

- (a) the GloBE Revenue of a jurisdiction for a Fiscal Year is the sum of the revenue of all Constituent Entities located in the jurisdiction for such Fiscal Year, taking into account the adjustments calculated in accordance with Chapter 3; and
- (b) the GloBE Income or Loss of a jurisdiction for a Fiscal Year is the Net GloBE Income of that jurisdiction, if any, or the Net GloBE Loss of that jurisdiction.

5.5.4. An election under Article 5.5 shall not apply to a Constituent Entity that is a Stateless

Constituent Entity or an Investment Entity and the revenue and GloBE Income or Loss of a Stateless Constituent Entity and of an Investment Entity shall be excluded from the computations in Article 5.5.3.

Article 5.6. Minority-Owned Constituent Entities

5.6.1. The computation of the Effective Tax Rate and Top-up Tax for a jurisdiction in accordance with Chapters 3 to 7, and Article 8.2 with respect to members of a Minority-Owned Subgroup shall apply as if they were a separate MNE Group. The Adjusted Covered Taxes and GloBE Income or Loss of members of a Minority-Owned Subgroup are excluded from the determination of the remainder of the MNE Group's Effective Tax Rate in Article 5.1.1 and Net GloBE Income in Article 5.1.2.

5.6.2. The Effective Tax Rate and Top-up Tax of a Minority-Owned Constituent Entity that is not a member of a Minority-Owned Subgroup is computed on an entity basis in accordance with Chapters 3 to 7, and Article 8.2. The Adjusted Covered Taxes and GloBE Income or Loss of the Minority-Owned Constituent Entity are excluded from the determination of the remainder of the MNE Group's Effective Tax Rate in Article 5.1.1 and Net GloBE Income in Article 5.1.2. This provision does not apply if the Minority-Owned Constituent Entity is an Investment Entity.

6 Corporate Restructurings and Holding Structures

Operation of the rules in this chapter

Chapter 6 contains rules relating to acquisitions, disposals and Joint Ventures.

- Article 6.1 supplements Article 1.1 by providing further rules for applying the consolidated revenue threshold in the case of merger and demerger transactions that took place in the prior four year period.
- Article 6.2 provides special rules for the application of the GloBE Rules that apply when a Constituent Entity enters or leaves an MNE Group during the Fiscal Year.
- Article 6.3 provides special rules for the treatment of transfers of assets and liabilities including as part of a reorganisation.
- Article 6.4 brings certain Joint Ventures within the scope of the GloBE Rules.
- Article 6.5 provides special rules for Multi-Parented MNE Groups.

Article 6.1. Application of Consolidated Revenue Threshold to Group Mergers and Demergers

6.1.1. For the purposes of Article 1.1

- (a) If two or more Groups merge to form a single Group in any of the four Fiscal Years prior to the tested Fiscal Year, then the consolidated revenue threshold of the MNE Group for any Fiscal Year prior to the merger is deemed to be met for that year if the sum of the revenue included in each of their Consolidated Financial Statements for that year is equal to or greater than EUR 750 million.
- (b) Where an Entity that is not a member of any Group (target) merges with an Entity or Group (acquirer) in the tested Fiscal Year and the target or acquirer does not have Consolidated Financial Statements in any of the four Fiscal Years prior to the tested Fiscal Year because it was not a member of any Group in that year, the consolidated revenue threshold of the MNE Group is deemed to be met for that year if the sum of the revenue included in each of their Financial Statements or Consolidated Financial Statements for that year is equal to or greater than EUR 750 million.
- (c) Where a single MNE Group within the scope of the GloBE Rules demerges into two or more Groups (each a demerged Group), the consolidated revenue threshold is deemed to be met by a demerged Group:
 - i. with respect to the first tested Fiscal Year ending after the demerger, if the demerged

Group has annual revenues of EUR 750 million or more in that year;

- ii. with respect to the second to fourth tested Fiscal Years ending after the demerger, if the demerged Group has annual revenues of EUR 750 million or more in at least two of the Fiscal Years following the year of the demerger.

6.1.2. For the purposes of Article 6.1.1 a merger is any arrangement where :

- (a) all or substantially all of the Group Entities of two or more separate Groups are brought under common control such that they constitute Group Entities of a combined Group; or
- (b) an Entity that is not a member of any Group is brought under common control with another Entity or Group such that they constitute Group Entities of a combined Group.

6.1.3. For the purposes of Article 6.1.1 a demerger is any arrangement where the Group Entities of a single Group are separated into two or more Groups that are no longer consolidated by the same Ultimate Parent Entity.

Article 6.2. Constituent Entities joining and leaving an MNE Group

6.2.1. Except to the extent provided in Article 6.2.2, the following provisions apply where an Entity (the target) becomes or ceases to be a Constituent Entity of an MNE Group as a result of a transfer of direct or indirect Ownership Interests in such Entity during the Fiscal Year (the acquisition year):

- (a) where the target joins or leaves a Group or the target becomes the Ultimate Parent Entity of a new Group, the target will be treated as a member of the Group for the purposes of the GloBE Rules if any portion of its assets, liabilities, income, expenses or cash flows are included on a line-by-line basis in the Consolidated Financial Statements of the Ultimate Parent Entity in the acquisition year;
- (b) in the acquisition year, an MNE Group shall take into account only the Financial Accounting Net Income or Loss and Adjusted Covered Taxes of the target that are taken into account in the Consolidated Financial Statements of the Ultimate Parent Entity for purposes of applying the GloBE Rules;
- (c) in the acquisition year and each succeeding year, the target shall determine its GloBE Income or Loss and Adjusted Covered Taxes using its historical carrying value of the assets and liabilities;
- (d) the computation of the target's Eligible Payroll Costs under Article 5.3.3 shall take into account only those costs reflected in the Consolidated Financial Statements of the Ultimate Parent Entity;
- (e) the computation of carrying value of the target's Eligible Tangible Assets for purposes of Article 5.3.4 shall be adjusted proportionally to correspond with the length of the relevant Fiscal Year that the target was a member of the MNE Group;
- (f) with the exception of the GloBE Loss Deferred Tax Asset, the deferred tax assets and deferred tax liabilities of a Constituent Entity that are transferred between MNE Groups shall be taken into account under the GloBE Rules by the acquiring MNE Group in the same manner and to the same extent as if the acquiring MNE Group controlled the Constituent Entity when such assets and liabilities arose;
- (g) deferred tax liabilities of a target that have previously been included in its Total Deferred Tax Adjustment Amount shall be treated as reversed for purposes of applying Article 4.4.4

by the disposing MNE Group and treated as arising in the acquisition year for purposes of applying Article 4.4.4 by the acquiring MNE Group, except that in such cases any subsequent reduction to Covered Taxes under Article 4.4.4 shall have effect in the year in which the amount is recaptured ; and

- (h) if the target is a Parent Entity and it is a Group Entity of two or more MNE Groups during the acquisition year, it shall apply separately the provisions of the IIR to its Allocable Shares of the Top-up Tax of Low-Taxed Constituent Entities determined for each MNE Group.

6.2.2. For purposes of the GloBE Rules, the acquisition or disposal of a Controlling Interest in a Constituent Entity will be treated as an acquisition or disposal of the assets and liabilities if the jurisdiction in which the target Constituent Entity is located, or in the case of a Tax Transparent Entity, the jurisdiction in which the assets are located, treats the acquisition or disposal of that Controlling Interest in the same or similar manner as an acquisition or disposition of the assets and liabilities and imposes a Covered Tax on the seller based on the difference between the tax basis and the consideration paid in exchange for the Controlling Interest or the fair value of the assets and liabilities.

Article 6.3. Transfer of Assets and Liabilities

6.3.1. In the case of a disposition or acquisition of assets and liabilities, a disposing Constituent Entity will include the gain or loss on disposition in the computation of its GloBE Income or Loss and an acquiring Constituent Entity will determine its GloBE Income or Loss using the acquiring Constituent Entity's carrying value of the acquired assets and liabilities determined under the accounting standard used in preparing Consolidated Financial Statements of the Ultimate Parent Entity.

6.3.2. If the disposition or acquisition of assets and liabilities is part of a GloBE Reorganisation Article 6.3.1 shall not apply and:

- (a) a disposing Constituent Entity will exclude any gain or loss on the disposition from the computation of its GloBE Income or Loss; and
- (b) an acquiring Constituent Entity will determine its GloBE Income or Loss after the acquisition using the disposing Entity's carrying values of the acquired assets and liabilities upon disposition.

6.3.3. If a disposition or acquisition of assets and liabilities is part of a GloBE Reorganisation in which a disposing Constituent Entity recognises Non-qualifying Gain or Loss, Articles 6.3.1 and 6.3.2 shall not apply and:

- (a) the disposing Constituent Entity will include gain or loss on the disposition in its GloBE Income or Loss computation to the extent of the Non-qualifying Gain or Loss; and
- (b) an acquiring Constituent Entity will determine its GloBE Income or Loss after the acquisition using the disposing Entity's carrying value of the acquired assets and liabilities upon disposition adjusted consistent with local tax rules to account for the Non-qualifying Gain or Loss.

6.3.4. At the election of the Filing Constituent Entity, a Constituent Entity of an MNE Group that is required or permitted to adjust the basis of its assets and the amount of its liabilities to fair value for tax purposes in the jurisdiction in which it is located, shall:

- (a) Include in the computation of its GloBE Income or Loss an amount of gain or loss in respect

of each of its assets and liabilities that is equal to:

- i. the difference between the carrying value for financial accounting purposes of the asset or liability immediately before and the fair value of the asset or liability immediately after the date of the event that triggered the tax adjustment (the triggering event);
 - ii. decreased (or increased) by the Non-Qualifying Gain (or Loss), if any, arising in connection with the triggering event;
- (b) use the fair value for financial accounting purposes of the asset or liability immediately after the triggering event to determine GloBE Income or Loss in Fiscal Years ending after the triggering event; and
- (c) include the net total of the amounts determined in 6.3.4(a) in the Constituent Entity's GloBE Income or Loss in one of the following ways:
- i. the net total of the amounts is included in the Fiscal Year in which the triggering event occurs; or
 - ii. an amount equal to the net total of the amounts divided by five is included in the Fiscal Year in which the triggering event occurs and in each of the immediate four subsequent Fiscal Years, unless the Constituent Entity leaves the MNE Group in a Fiscal Year within this period, in which case the remaining amount will be wholly included in that Fiscal Year.

Article 6.4. Joint Ventures

6.4.1. The GloBE Rules shall apply to a Joint Venture and its JV Subsidiaries as follows for each Fiscal Year:

- (a) Chapters 3 to 7, and Article 8.2 shall apply for purposes of computing any Top-Up Tax of the Joint Venture and its JV Subsidiaries as if they were Constituent Entities of a separate MNE Group and as if the Joint Venture was the Ultimate Parent Entity of that Group;
- (b) a Parent Entity that holds directly or indirectly Ownership Interests in the Joint Venture or a JV Subsidiary shall apply the IIR with respect to its Allocable Share of the Top-up Tax of a member of the JV Group in accordance with Article 2.1 to Article 2.3; and
- (c) the JV Group Top-up Tax shall be reduced by each Parent Entity's Allocable Share of the Top-up Tax of each member of the JV Group that is brought into charge under a Qualified IIR under paragraph (b), and any remaining amount shall be added to the Total UTPR Top-up Tax Amount taken into account under Article 2.5.1.

Article 6.5. Multi-Parented MNE Groups

6.5.1. The following provisions apply to Multi-Parented MNE Groups:

- (a) the Entities and Constituent Entities of each Group are treated as members of a single MNE Group for purposes of the GloBE Rules (the Multi-Parented MNE Group);
- (b) an Entity (other than an Excluded Entity) shall be treated as a Constituent Entity if it is consolidated on a line-by-line basis by the Multi-Parented MNE Group or its Controlling Interests are held by Entities in the Multi-Parented MNE Group;

- (c) the Consolidated Financial Statements of the Multi-Parented MNE Group shall be the Consolidated Financial Statements referred to in the definition of Stapled Structure or Dual-listed arrangement (as relevant) prepared under an Acceptable Financial Accounting Standard, which is deemed to be the accounting standard of the Ultimate Parent Entity;
- (d) the Ultimate Parent Entities of the separate Groups that comprise the Multi-Parented MNE Group shall be the Ultimate Parent Entities of the Multi-Parented MNE Group (when applying the GloBE Rules in respect of a Multi-Parented MNE Group, references to an Ultimate Parent Entity shall apply, as required, as if they were references to multiple Ultimate Parent Entities);
- (e) the Parent Entities of the Multi-Parented MNE Group (including each Ultimate Parent Entity) located in [insert name of implementing jurisdiction] shall apply the IIR in accordance with Article 2.1 to Article 2.3 with respect to their Allocable Share of the Top-up Tax of the Low-Taxed Constituent Entity;
- (f) all of the Constituent Entities of the Multi-Parented MNE Group located in [insert name of implementing jurisdiction] shall apply the UTPR in accordance with Article 2.4 to Article 2.6 taking into account the Top-up Tax of each Low-Taxed Constituent Entity of the Multi-Parented MNE Group; and
- (g) the Ultimate Parent Entities are required to submit the GloBE Information Return in accordance with Article 8.1, unless they appoint a single Designated Filing Entity and that return shall include the information concerning each of the Groups that comprise the Multi-Parented MNE Group.

7 Tax neutrality and distribution regimes

Operation of the rules in this chapter

Chapter 7 deals with the application of the GloBE Rules to certain tax neutrality and other distribution regimes.

- Article 7.1 and Article 7.2 provide special rules in relation to Ultimate Parent Entities that are subject to a tax neutrality regime (such as a tax transparency regime or a Deductible Dividend Regime).
- Article 7.3 provides special rules in relation to certain tax regimes that subject an Entity to tax on its earnings when those earnings are distributed or deemed distributed.
- Article 7.4 to Article 7.6 provide special rules in relation to controlled Investment Entities that seek to preserve the tax neutrality of these Entities without giving rise to any leakage under the GloBE Rules.

Article 7.1. Ultimate Parent Entity that is a Flow-through Entity

7.1.1. The GloBE Income for a Fiscal Year of a Flow-through Entity that is the Ultimate Parent Entity of an MNE Group shall be reduced by the amount of GloBE Income attributable to each Ownership Interest if:

- (a) the holder of the Ownership Interest is subject to tax on such income for a taxable period that ends within 12 months of the end of the MNE Group's Fiscal Year and:
 - (i) the holder of the Ownership Interest is subject to tax on the full amount of such income at a nominal rate that equals or exceeds the Minimum Rate; or
 - (ii) it can be reasonably expected that the aggregate amount of Adjusted Covered Taxes of the Ultimate Parent Entity and Taxes of the holder of the Ownership Interest on such income equals or exceeds the amount that results from multiplying the full amount of such income by the Minimum Rate; or
- (b) the holder is a natural person that:
 - (i) is a tax resident in the UPE Jurisdiction; and
 - (ii) holds Ownership Interests that, in the aggregate, are a right to 5% or less of the profits and assets of the Ultimate Parent Entity; or
- (c) the holder is a Governmental Entity, an International Organisation, a Non-profit Organisation, or a Pension Fund that
 - (i) is resident in the UPE Jurisdiction; and

- (ii) holds Ownership Interests that, in the aggregate, are a right to 5% or less of the profits and assets of the Ultimate Parent Entity.

7.1.2. In computing its GloBE Loss for a Fiscal Year, a Flow-through Entity that is the Ultimate Parent Entity of an MNE Group shall reduce its GloBE Loss for such Fiscal Year by the amount of GloBE Loss attributable to each Ownership Interest, except to the extent that the holders of Ownership Interests are not allowed to use the loss in computing their separate taxable income.

7.1.3. A Flow-through Entity that reduces its GloBE Income pursuant to Article 7.1.1 shall reduce its Covered Taxes proportionally.

7.1.4. Articles 7.1.1 through 7.1.3 shall apply to a Permanent Establishment:

- (a) through which a Flow-Through Entity that is the Ultimate Parent Entity of an MNE Group wholly or partly carries out its business; or
- (b) through which the business of a Tax Transparent Entity is wholly or partly carried out if the Ultimate Parent Entity's Ownership Interest in that Tax Transparent Entity is held directly or through a Tax Transparent Structure.

Article 7.2. Ultimate Parent Entity subject to Deductible Dividend Regime

7.2.1. For purposes of computing its GloBE Income or Loss for a Fiscal year, an Ultimate Parent Entity that is subject to a Deductible Dividend Regime shall reduce (but not below zero) its GloBE Income for such Fiscal Year by the amount that is distributed as a Deductible Dividend within 12 months of the end of the Fiscal Year if:

- (a) the dividend is subject to tax in the hands of the dividend recipient for a taxable period that ends within 12 months of the end of the MNE Group's Fiscal Year, and:
 - (i) the dividend recipient is subject to tax on such dividend at a nominal rate that equals or exceeds the Minimum Rate;
 - (ii) it can be reasonably expected that the aggregate amount of Adjusted Covered Taxes of the Ultimate Parent Entity and Taxes paid by the dividend recipient on the dividend income equals or exceeds the amount that results from multiplying the full amount of such income by the Minimum Rate; or
 - (iii) the dividend recipient is a natural person and the dividend is a patronage dividend from a supply Cooperative; or
- (b) the dividend recipient is a natural person that:
 - (i) is a tax resident in the UPE Jurisdiction; and
 - (ii) holds Ownership Interests that, in the aggregate, are a right to 5% or less of the profits and assets of the Ultimate Parent Entity.
- (c) the dividend recipient is resident in the UPE Jurisdiction and is:
 - (i) a Governmental Entity,
 - (ii) an International Organisation,
 - (iii) a Non-profit Organisation or
 - (iv) a Pension Fund that is not a Pension Services Entity.

7.2.2. An Ultimate Parent Entity that reduces its GloBE Income pursuant to Article 7.2.1 shall reduce its Covered Taxes (other than the Taxes for which the dividend deduction was allowed) proportionally and shall reduce its GloBE Income by the same amount.

7.2.3. If the Ultimate Parent Entity holds an Ownership Interest in another Constituent Entity subject to the Deductible Dividend Regime (directly or through a chain of such Constituent Entities), Articles 7.2.1 and 7.2.2 shall apply to each other Constituent Entity in the UPE Jurisdiction that is subject to the Deductible Dividend Regime to the extent that its GloBE Income is further distributed by the Ultimate Parent Entity to recipients that meet the requirements of Article 7.2.1.

7.2.4. Patronage dividends from a supply Cooperative are subject to tax to the extent they reduce an expense or cost that is deductible in the computation of the recipient's taxable income.

Article 7.3. Eligible Distribution Tax Systems

7.3.1. A Filing Constituent Entity may make an annual election with respect to a Constituent Entity that is subject to an Eligible Distribution Tax System to add the amount of Deemed Distribution Tax determined under Article 7.3.2 to Adjusted Covered Taxes for the Fiscal Year. An election under this Article shall apply to all Constituent Entities located in the jurisdiction.

7.3.2. The amount of Deemed Distribution Tax is the lesser of:

- (a) the amount of Adjusted Covered Taxes necessary to increase the Effective Tax Rate computed under Article 5.2.1 for the jurisdiction for the Fiscal Year to the Minimum Rate; or
- (b) the amount of tax that would have been due if the Constituent Entities located in the jurisdiction had distributed all of their income that is subject to the Eligible Distribution Tax Regime during such year.

7.3.3. An annual Deemed Distribution Tax Recapture Account is established for each Fiscal Year in which the election in Article 7.3.1 applies. A Deemed Distribution Tax Recapture Account is increased by the amount of the Deemed Distribution Tax determined under Article 7.3.2 for the jurisdiction for the Fiscal Year for which it was established. At the end of each succeeding Fiscal Year, the outstanding balances of Deemed Distribution Tax Recapture Accounts established for prior Fiscal Years are reduced in chronological order and to the extent thereof, but not below zero:

- (a) first by Taxes paid by the Constituent Entities during the Fiscal Year in relation to actual or deemed distributions;
- (b) then by the amount of any Net GloBE Loss of the jurisdiction multiplied by the Minimum Rate; and
- (c) then by any amount of Recapture Account Loss Carry-forward applied to the current Fiscal Year pursuant to Article 7.3.4.

7.3.4. A Recapture Account Loss Carry-forward shall be established for the jurisdiction when the amount described in Article 7.3.3(b) exceeds the outstanding balance of the Deemed Distribution Tax Recapture Accounts. The Recapture Account Loss Carry-forward shall be in an amount equal to such excess and shall be taken into account in subsequent Fiscal Years as a reduction to Deemed Distribution Tax Recapture Accounts in such Fiscal Years. When such amount is taken into account in a subsequent Fiscal Year, the Recapture Account Loss Carry-forward must be reduced by that amount.

7.3.5. If there is an outstanding balance of a Deemed Distribution Tax Recapture Account (maintained in accordance with Article 7.3.3) on the last day of the fourth Fiscal Year after the Fiscal

Year for which such account was established, the Effective Tax Rate and Top-up Tax for the Fiscal Year for which the account was established must be recalculated under Article 5.4.1 by treating the balance of the Deemed Distribution Tax Recapture Account as a reduction to the Adjusted Covered Taxes previously determined for such year.

7.3.6. Taxes paid during the Fiscal Year in relation to actual or deemed distributions are not included in Adjusted Covered Taxes to the extent they reduce a Deemed Distribution Tax Recapture Account under Article 7.3.3.

7.3.7. In the Fiscal Year that a Departing Constituent Entity leaves the MNE Group or transfers substantially all of its assets,

- (a) the Effective Tax Rate and Top-up Tax for each preceding year for which a Deemed Distribution Tax Recapture Account is outstanding is re-calculated in accordance with the principles of Article 5.4.1. by treating the balance of the Deemed Distribution Tax Recapture Account as a reduction to the Adjusted Covered Taxes previously determined for such year; and
- (b) any amount of incremental Top-up Tax resulting from such recalculation shall be multiplied by the Disposition Recapture Ratio to determine the Additional Current Top-up Tax for purposes of Article 5.2.3.

7.3.8. The Disposition Recapture Ratio is determined for each Departing Constituent Entity using the following formula:

$$\frac{\text{GloBE Income of the CE}}{\text{Net Income of the jurisdiction}}$$

Where:

- (a) GloBE Income of the CE is the sum of GloBE Income of the Departing Constituent Entity determined in accordance with Chapter 3 for each Fiscal Year corresponding to the Deemed Distribution Tax Recapture Accounts for the jurisdiction; and
- (b) Net Income of the jurisdiction is the sum of the Net GloBE Income of the jurisdiction determined in accordance with Article 5.1.2 for each Fiscal Year corresponding to the Deemed Distribution Tax Recapture Accounts for the jurisdiction.

Article 7.4. Effective Tax Rate Computation for Investment Entities

7.4.1. The rules of Article 7.4 apply to Constituent Entities that meet the definition of an Investment Entity, except Investment Entities that are Tax Transparent Entities or subject to an election under Article 7.5 or Article 7.6.

7.4.2. The Effective Tax Rate for an Investment Entity that is a Constituent Entity shall be calculated separately from the Effective Tax Rate of the jurisdiction in which it is located. The Effective Tax Rate for each such Investment Entity is equal to the Investment Entity's Adjusted Covered Taxes divided by the MNE Group's Allocable Share of the Investment Entity's GloBE Income determined under Chapter 3. If there is more than one Investment Entity located in the jurisdiction, the Adjusted Covered Taxes and the MNE Group's Allocable Share of each Investment Entity's GloBE Income or Loss determined for each such Investment Entity are combined to compute the Effective Tax Rate of all such Investment Entities.

7.4.3. An Investment Entity's Adjusted Covered Taxes is the sum of the Adjusted Covered Taxes determined for the Investment Entity under Article 4.1 attributable to the MNE Group's Allocable Share of the Investment Entity's GloBE Income and the Covered Taxes allocated to the Investment

Entity under Article 4.3. The Investment Entity's Adjusted Covered Taxes does not include any Covered Taxes accrued by the Investment Entity attributable to income that is not part of the MNE Group's Allocable Share of the Investment Entity's GloBE Income.

7.4.4. The MNE Group's Allocable Share of the Investment Entity's GloBE Income is equal to the Allocable Share of the Investment Entity's GloBE Income or Loss that would be determined for the Ultimate Parent Entity in accordance with the rules of Article 2.2.2 taking into account only interests that are not subject to an election under Article 7.5 or Article 7.6.

7.4.5. The Top-up Tax of a Constituent Entity that is an Investment Entity shall be an amount equal to the Top-up Tax Percentage for the Investment Entity multiplied by the excess of the MNE Group's Allocable Share of the Investment Entity's GloBE Income over the Substance-based Income Exclusion for the Investment Entity. The Top-up Tax Percentage for an Investment Entity shall be the percentage point excess, if any, of the Minimum Rate over the Effective Tax Rate of the Investment Entity. If there is more than one Investment Entity located in the jurisdiction, the MNE Group's Allocable Share of the Investment Entity's GloBE Income and the Substance-based Income Exclusion determined for each such Investment Entity are combined to compute the Effective Tax Rate of all such Investment Entities.

7.4.6. The Substance-based Income Exclusion for an Investment Entity shall be determined in accordance with the principles in Article 5.3 without regard to the exception in Article 5.3.2, and by taking into account only Eligible Tangible Assets and Eligible Payroll Costs of Eligible Employees of the Investment Entities reduced in proportion to the MNE Group's Allocable Share of the Investment Entity's GloBE Income to the Investment Entity's total GloBE Income.

Article 7.5. Investment Entity Tax Transparency Election

7.5.1. A Filing Constituent Entity may elect to treat a Constituent Entity that is an Investment Entity or an Insurance Investment Entity as a Tax Transparent Entity if the Constituent Entity-owner is subject to tax in its location under a mark-to-market or similar regime based on the annual changes in the fair value of its Ownership Interest in the Entity and the tax rate applicable to the Constituent Entity-owner with respect to such income equals or exceeds the Minimum Rate. For this purpose, a Constituent Entity that indirectly owns an Ownership Interest in an Investment Entity or Insurance Investment Entity through a direct Ownership Interest in another Investment Entity or Insurance Investment Entity is considered to be subject to tax under a mark-to-market or similar regime with respect to the indirect Ownership Interest in the first-mentioned Entity if it is subject to a mark-to-market or similar regime with respect to the direct Ownership Interest in the second-mentioned Entity.

7.5.2. The election under this Article is a Five-Year Election. If the election is revoked, gain or loss from the disposition of an asset or liability held by the Investment Entity shall be determined based on the fair value of the assets or liabilities on the first day of the revocation year.

Article 7.6. Taxable Distribution Method Election

7.6.1. At the election of the Filing Constituent Entity, a Constituent Entity-owner that is not an Investment Entity may apply the Taxable Distribution Method with respect to its Ownership Interest in a Constituent Entity that is an Investment Entity if the Constituent Entity-owner can be reasonably expected to be subject to tax on distributions from the Investment Entity at a tax rate that equals or exceeds the Minimum Rate.

7.6.2. Under the Taxable Distribution Method:

- (a) distributions and deemed distributions of the Investment Entity's GloBE Income are included in the GloBE Income of the Constituent Entity-owner (other than an Investment Entity) that received the distribution;
- (b) the Local Creditable Tax Gross-up is included in the GloBE Income and Adjusted Covered Taxes of the Constituent Entity-owner (other than an Investment Entity) that received the distribution;
- (c) the Constituent Entity-owner's proportionate share of the Investment Entity's Undistributed Net GloBE Income for the Tested Year is treated as GloBE Income of the Investment Entity for the Reporting Fiscal Year and the result of multiplying the Minimum Rate by such GloBE Income is treated as Top-up Tax of a Low-Tax Constituent Entity in the Fiscal Year for purposes of Chapter 2; and
- (d) the Investment Entity's GloBE Income or Loss for the Fiscal Year and any Adjusted Covered Taxes attributable to such income are excluded from all Effective Tax Rate computations under Chapter 5 and Articles 7.4.2 to 7.4.5, except as provided in paragraph (b).

7.6.3. The Undistributed Net GloBE Income for a Fiscal Year is the amount of the Investment Entity's GloBE Income, if any, for the Tested Year reduced (but not below zero) by:

- (a) any Covered Taxes of the Investment Entity;
- (b) distributions and deemed distributions to shareholders other than Constituent Entities that are Investment Entities in the Testing Period;
- (c) GloBE Losses arising in the Testing Period; and
- (d) Investment Loss Carry-forwards.

7.6.4. Undistributed Net GloBE Income for the Tested Year cannot be reduced by distributions or deemed distributions to the extent that such distributions were treated as a reduction to Undistributed Net GloBE Income of a previous Tested Year. For purposes of computing Undistributed Net GloBE Income, a GloBE Loss is reduced to the extent it reduced Undistributed Net GloBE Income at the end of a previous Fiscal Year. If a GloBE Loss for a Fiscal Year is not reduced to zero before the end of the last Tested Period that includes such Fiscal Year, the remainder becomes an Investment Loss Carry-forward and is reduced in the same manner as a GloBE Loss in subsequent Fiscal Years.

7.6.5. For purposes of Article 7.6,

- (a) the Tested Year is the third year preceding the Reporting Fiscal Year;
- (b) the Testing Period is the period beginning with the first day of the Tested Year and ending with the last day of the Reporting Fiscal Year that the Ownership Interest was held by a Group Entity;
- (c) a deemed distribution arises when a direct or indirect Ownership Interest in the Investment Entity is transferred to a non-Group Entity and is equal to the proportionate share of the Undistributed Net GloBE Income attributable to such Ownership Interest on the date of such transfer (determined without regard to the deemed distribution); and
- (d) the Local Creditable Tax Gross-up is the amount of Covered Taxes incurred by the Investment Entity that is allowed as a credit against the Constituent Entity-owner's tax liability arising in connection with a distribution from the Investment Entity.

7.6.6. The election under this Article is a Five-Year Election. If the election is revoked, Constituent Entity-owner's proportionate share of the Investment Entity's Undistributed Net GloBE

Income for the Tested Year at the end of the Fiscal Year preceding the revocation year is treated as GloBE Income of the Investment Entity for the revocation year and the result of multiplying the Minimum Rate by such GloBE Income is treated as Top-up Tax of a Low-Tax Constituent Entity in the revocation year for purposes of Chapter 2.

8 Administration

Operation of the rules in this chapter

Chapter 8 addresses certain administrative aspects of the GloBE Rules.

- Article 8.1 sets out an MNE Groups obligation to file a standardised information return in each jurisdiction that has introduced the GloBE Rules in order to provide information on the tax calculations made by the MNE under the GloBE Rules.
- Article 8.2 allows for the development of certain safe harbours.
- Article 8.3 facilitates co-ordination between tax administrations in the application of the GloBE Rules through the development Agreed Administrative Guidance.

Article 8.1. Filing obligation

8.1.1. Subject to Article 8.1.2, each Constituent Entity located in [insert name of implementing-Jurisdiction] shall file a GloBE Information Return conforming to the requirements of Articles 8.1.4 to 8.1.6 with the tax administration of [insert name of implementing-Jurisdiction]. The return may be filed by either the Constituent Entity itself or by a Designated Local Entity on its behalf.

8.1.2. A Constituent Entity is not obligated to file a GloBE Information Return with the tax administration of [insert name of implementing-Jurisdiction] if a GloBE Information Return conforming to the requirements of Articles 8.1.4 to 8.1.6 has been filed by either:

- (a) the Ultimate Parent Entity located in a jurisdiction that has a Qualifying Competent Authority Agreement in effect with [insert name of implementing-Jurisdiction] for the Reporting Fiscal Year; or
- (b) the Designated Filing Entity located in a jurisdiction that has a Qualifying Competent Authority Agreement in effect with [insert name of implementing-Jurisdiction] for the Reporting Fiscal Year.

8.1.3. Where Article 8.1.2 applies, a Constituent Entity located in [insert name of implementing-Jurisdiction] or the Designated Local Entity on its behalf, shall notify the tax administration of [insert name of implementing-Jurisdiction] of the identity of the Entity that is filing the GloBE Information Return and the jurisdiction in which it is located.

8.1.4. The GloBE Information Return shall be filed in a standard template that is developed in accordance with the GloBE Implementation Framework and shall include the following information concerning the MNE Group (which shall be specified, expanded or restricted in accordance with the GloBE Implementation Framework including through the development of simplified reporting procedures):

- (a) identification of the Constituent Entities, including their tax identification numbers (if they

- exist), the jurisdiction in which they are located and their status under the GloBE Rules,
- (b) Information on the overall corporate structure of the MNE Group including the Controlling Interests in the Constituent Entities held by other Constituent Entities;
 - (c) the information necessary to compute:
 - i. the Effective Tax Rate for each jurisdiction and the Top-up Tax of each Constituent Entity under Chapter 5;
 - ii. the Top-up Tax of a member of the JV Group under Chapter 6;
 - iii. the allocation of Top-Up Tax under the IIR, and the UTPR Top-Up Tax Amount to each jurisdiction, under Chapter 2;
 - (d) a record of the elections made in accordance with the relevant provisions of the GloBE Rules; and
 - (e) other information that is agreed as part of the GloBE Implementation Framework and is necessary to carry out the administration of the GloBE Rules.

8.1.5. The GloBE Information Return shall apply the definitions and instructions contained in the standard template that is developed in accordance with the GloBE Implementation Framework.

8.1.6. The GloBE Information Return and the notifications pursuant to this Article shall be filed with the tax administration of [insert name of implementing-Jurisdiction] no later than 15 months after the last day of the Reporting Fiscal Year.

8.1.7. The tax administration of [insert name of implementing-Jurisdiction] may modify the information, filing and notification requirements of the GloBE Information Return to align those requirements with those provided under the GloBE Implementation Framework (including the development of simplified reporting procedures).

8.1.8. The laws of [insert name of implementing-Jurisdiction] with respect to penalties, sanctions and the confidentiality of returns and return information shall apply to the GloBE Information Return.

Article 8.2. Safe Harbours

8.2.1. At the election of the Filing Constituent Entity, and notwithstanding Chapter 5, the Top-up Tax for a jurisdiction (the safe harbour jurisdiction) shall be deemed to be zero for a Fiscal Year when the Constituent Entities located in this jurisdiction are eligible for a GloBE Safe Harbour, pursuant to the conditions provided under the GloBE Implementation Framework and applicable for that Fiscal Year.

8.2.2. An election made for a jurisdiction under Article 8.2.1 shall not apply in circumstances where:

- (a) [insert name of implementing-Jurisdiction] could be allocated Top-up Tax under the GloBE Rules if the Effective Tax Rate for the safe harbour jurisdiction computed in accordance with Chapter 5 was below the Minimum Rate; and
- (b) the tax administration of [insert name of implementing-Jurisdiction] notifies the Liable Constituent Entity (or Entities) within 36 months after the filing of the GloBE Information Return of specific facts and circumstances that may have materially affected the eligibility of the Constituent Entities located in the safe harbour jurisdiction for the relevant safe harbour and invites the Liable Constituent Entity (or Entities) to clarify within six months the effect of those facts and circumstances on the eligibility of those Constituent Entities

for that safe harbour; and

- (c) the Liable Constituent Entity (or Entities) fail(s) to demonstrate within the response period that those facts and circumstances did not materially affect the eligibility of the Constituent Entities for the relevant safe harbour.

Article 8.3. Administrative Guidance

8.3.1. The tax administration of [insert name of implementing-Jurisdiction] shall, subject to any requirements of domestic law, apply the GloBE Rules in accordance with any Agreed Administrative Guidance.

9 Transition rules

Operation of the rules in this chapter

Chapter 9 sets out certain Transitional Rules.

- Article 9.1 provides the transition rules that apply where an MNE Group enters within the scope of the GloBE Rules.
- Article 9.2 modifies the percentages to be applied in the calculation of the Substance-based Income Exclusion under Article 5.3 during a transitional period.
- Article 9.3 provides an exclusion from the UTPR for MNE Groups that are in the initial phase of their international activity.
- Article 9.4 provides transitional relief for filing obligations.

Article 9.1. Tax Attributes Upon Transition

9.1.1. When determining the Effective Tax Rate for a jurisdiction in a Transition Year, and for each subsequent year, the MNE Group shall take into account all of the deferred tax assets and deferred tax liabilities reflected or disclosed in the financial accounts of all of the Constituent Entities in a jurisdiction for the Transition Year. Such deferred tax assets and liabilities must be taken into account at the lower of the Minimum Rate or the applicable domestic tax rate. A deferred tax asset that has been recorded at a rate lower than the Minimum Rate may be taken into account at the Minimum Rate if the taxpayer can demonstrate that the deferred tax asset is attributable to a GloBE Loss. For purposes of applying this Article, the impact of any valuation adjustment, or accounting recognition adjustment with respect to a deferred tax asset is disregarded.

9.1.2. Deferred tax assets arising from items excluded from the computation of GloBE Income or Loss under Chapter 3 must be excluded from the Article 9.1.1 computation when such deferred tax assets are generated in a transaction that takes place after 30 November 2021.

9.1.3. In the case of a transfer of assets between Constituent Entities after 30 November 2021 and before the commencement of a Transition Year, the basis in the acquired assets (other than inventory) shall be based upon the disposing Entity's carrying value of the transferred assets upon disposition with the deferred tax assets and liabilities brought into GloBE determined on that basis.

Article 9.2. Transitional relief for the Substance-based Income Exclusion

9.2.1. For the purposes of applying Article 5.3.3, the value of 5% shall be replaced with the value set out in the table set out below for each Fiscal Year beginning in each of the following calendar years:

| Fiscal Year Beginning In | Article 5.3.3 Rate |
|--------------------------|--------------------|
| 2023 | 10% |
| 2024 | 9.8% |
| 2025 | 9.6% |
| 2026 | 9.4% |
| 2027 | 9.2% |
| 2028 | 9.0% |
| 2029 | 8.2% |
| 2030 | 7.4% |
| 2031 | 6.6% |
| 2032 | 5.8% |

9.2.2. For the purposes of applying Article 5.3.4, the value of 5% shall be replaced with the value set out in the table set out below for each Fiscal Year beginning in each of the following calendar years:

| Fiscal Year Beginning In | Article 5.3.4 Rate |
|--------------------------|--------------------|
| 2023 | 8.0% |
| 2024 | 7.8% |
| 2025 | 7.6% |
| 2026 | 7.4% |
| 2027 | 7.2% |
| 2028 | 7.0% |
| 2029 | 6.6% |
| 2030 | 6.2% |
| 2031 | 5.8% |
| 2032 | 5.4% |

Article 9.3. Exclusion from the UTPR of MNE Groups in the initial phase of their international activity

9.3.1. Subject to Article 9.3.4 the Top-up Tax that would otherwise be taken into account under Article 2.5.1 shall be reduced to zero during the initial phase of an MNE Group's international activity, notwithstanding the requirements otherwise provided in Chapter 5.

9.3.2. For the purposes of Article 9.3, an MNE Group is in its initial phase of its international activity if, for a Fiscal Year:

- (a) it has Constituent Entities in no more than six jurisdictions; and
- (b) the sum of the Net Book Values of Tangible Assets of all Constituent Entities located in all jurisdictions other than the Reference Jurisdiction does not exceed EUR 50 million.

9.3.3. For the purposes of Article 9.3.2, the Reference Jurisdiction of an MNE Group is the jurisdiction where the MNE Group has the highest total value of Tangible Assets for the Fiscal Year in which the MNE Group originally comes within the scope of the GloBE Rules. The total value of Tangible Assets in a jurisdiction is the sum of the Net Book Values of all Tangible Assets of all the Constituent Entities of the MNE Group that are located in that jurisdiction.

9.3.4. This Article 9.3 shall not apply for any Fiscal Year that starts later than five years after the first day of the first Fiscal Year when the MNE Group originally came within the scope of the GloBE Rules. For MNE Groups that are in scope of the GloBE Rules when they come into effect, the period of five years will start at the time the UTPR rules come into effect.

9.3.5. [Optional provision] If [insert name of implementing-Jurisdiction] is the Reference

Jurisdiction of the MNE Group pursuant to Article 9.3.3, then Article 9.3.1 shall not apply during the initial phase of that MNE Group's international activity and, during that initial phase:

- (a) [*Optional provision*] the Top-up Tax calculated for a Low-Taxed Constituent Entity that would be taken into account under Article 2.5.1 shall be reduced to zero if that Low-Taxed Constituent Entity is located in the Reference Jurisdiction, notwithstanding the requirements otherwise provided in Chapter 5; and
- (b) the UTPR Percentage of the jurisdictions other than the Reference Jurisdiction is deemed to be zero.

Article 9.4. Transitional relief for filing obligations

9.4.1. Notwithstanding Article 8.1.6, the GloBE Information Return or the notifications pursuant to Article 8.1 shall be filed with the tax administration of [insert name of implementing-Jurisdiction] no later than 18 months after the last day of the Reporting Fiscal Year that is the Transitional Year.

10 Definitions

Operation of the rules in this chapter

Chapter 10 sets out defined terms used elsewhere in the GloBE Rules.

- Article 10.1 sets out general definitions that are used in the GloBE Rules.
- Article 10.2 sets out certain definitions in respect of Flow-through Entities.
- Article 10.3 sets out definitional rules for determining the location of an Entity for the purposes of applying the GloBE Rules.

Article 10.1. Defined Terms

10.1.1. The terms set out below have the following definitions:

Acceptable Financial Accounting Standard means International Financial Reporting Standards (IFRS) and the generally accepted accounting principles of Australia, Brazil, Canada, Member States of the European Union, Member States of the European Economic Area, Hong Kong (China), Japan, Mexico, New Zealand, the People's Republic of China, the Republic of India, the Republic of Korea, Russia, Singapore, Switzerland, the United Kingdom, and the United States of America.

Accrued Pension Expense means the difference between the amount of pension liability expense included in the Financial Accounting Net Income or Loss and the amount contributed to a Pension Fund for the Fiscal Year.

Additional Current Top-up Tax is the amount of tax determined in Article 5.4 and any amount treated as Additional Current Top-up Tax determined under Article 5.4, such as the amount determined under Article 4.1.5 or Article 7.3.

Additional Tier One Capital means an instrument issued by a Constituent Entity pursuant to prudential regulatory requirements applicable to the banking sector that is convertible to equity or written down if a pre-specified trigger event occurs and that has other features which are designed to aid loss absorbency in the event of a financial crisis.

Additions to Covered Taxes is defined in Article 4.1.2.

Adjusted Asset Gain in respect of Aggregate Asset Gain that is subject to an election under Article 3.2.6 means an amount equal to the Aggregate Asset Gain in the Election Year, reduced by any amount of such gain that has been applied against the Net Asset Loss in a prior Loss Year under Article 3.2.6(b) or (c).

Adjusted Covered Taxes is defined in Article 4.1.1.

Aggregate Asset Gain in respect of an election under Article 3.2.6, means the net gain in the Election Year from the disposition of Local Tangible Assets by all Constituent Entities located in the jurisdiction excluding the gain or loss on a transfer of assets between Group Members.

Agreed Administrative Guidance means guidance on the interpretation or administration of the GloBE Rules issued by the Inclusive Framework.

Allocable Share of the Top-up Tax is defined in Article 2.2.1.

Annual Election means an election made by a Filing Constituent Entity and that applies only for the Fiscal Year for which the election is made.

Allocated Asset Gain in respect of an election under Article 3.2.6, means the Adjusted Asset Gain that is allocated to a Fiscal Year in the Lookback Period under Article 3.2.6(d).

Arm's Length Principle means the principle under which transactions between Constituent Entities must be recorded by reference to the conditions that would have been obtained between independent enterprises in comparable transactions and under comparable circumstances.

Asymmetric Foreign Currency Gains or Losses means foreign currency gains or losses of an entity whose accounting and tax functional currencies are different and that are:

- (a) included in the computation of a Constituent Entity's taxable income or loss and attributable to fluctuations in the exchange rate between its accounting functional currency and its tax functional currency;
- (b) included in the computation of a Constituent Entity's Financial Accounting Net Income or Loss and attributable to fluctuations in the exchange rate between its tax functional currency and its accounting functional currency;
- (c) included in the computation of a Constituent Entity's Financial Accounting Net Income or Loss and attributable to fluctuations in the exchange rate between a third foreign currency and its accounting functional currency; and
- (d) attributable to fluctuations in the exchange rate between a third foreign currency and its tax functional currency, whether or not such foreign currency gain or loss is included in taxable income.

The tax functional currency is the functional currency used to determine the Constituent Entity's taxable income or loss for a Covered Tax in the jurisdiction in which it is located. The accounting functional currency is the functional currency used to determine the Constituent Entity's Financial Accounting Net Income or Loss. A third foreign currency is a currency that is not the Constituent Entity's tax functional currency or accounting functional currency.

Authorised Accounting Body is the body with legal authority in a jurisdiction to prescribe, establish, or accept accounting standards for financial reporting purposes.

Authorised Financial Accounting Standard, in respect of any Entity, means a set of generally acceptable accounting principles permitted by an Authorised Accounting Body in the jurisdiction where that Entity is located.

Average GloBE Income or Loss is defined in Article 5.5.2.

Average GloBE Revenue is defined in Article 5.5.2.

Commentary means the Commentary to the GloBE Rules as developed by the OECD/G20 Inclusive Framework on Base Erosion and Profit Shifting.

Consolidated Financial Statements means:

- (a) the financial statements prepared by an Entity in accordance with an Acceptable Financial Accounting Standard, in which the assets, liabilities, income, expenses and cash flows of that Entity and the Entities in which it has a Controlling Interest are presented as those of a single economic unit;

- (b) where an Entity meets the definition of a Group under Article 1.2.3, the financial statements of the Entity that are prepared in accordance with an Acceptable Financial Accounting Standard;
- (c) where the Ultimate Parent Entity has financial statements described in paragraph (a) or (b) that are not prepared in accordance with an Acceptable Financial Accounting Standard, the financial statements are those that have been prepared subject to adjustments to prevent any Material Competitive Distortions; and
- (d) where the Ultimate Parent Entity does not prepare financial statements described in the paragraphs above, the Consolidated Financial Statements of the Ultimate Parent Entity are those that would have been prepared if such Entity were required to prepare such statements in accordance with an Authorised Financial Accounting Standard that is either an Acceptable Financial Accounting Standard or another financial accounting standard that is adjusted to prevent any Material Competitive Distortions.

Constituent Entity (CE) is defined in Article 1.3.1.

Constituent Entity-owner means a Constituent Entity that directly or indirectly owns an Ownership Interest in another Constituent Entity of the same MNE Group.

Controlled Foreign Company Tax Regime means a set of tax rules (other than an IIR) under which a direct or indirect shareholder of a foreign entity (the controlled foreign company or CFC) is subject to current taxation on its share of part or all of the income earned by the CFC, irrespective of whether that income is distributed currently to the shareholder.

Controlling Interest means an Ownership Interest in an Entity such that the interest holder:

- (a) is required to consolidate the assets, liabilities, income, expenses and cash flows of the Entity on a line-by-line basis in accordance with an Acceptable Financial Accounting Standard; or
- (b) would have been required to consolidate the assets, liabilities, income, expenses and cash flows of the Entity on a line-by-line basis if the interest holder had prepared Consolidated Financial Statements.

A Main Entity is deemed to have the Controlling Interests of its Permanent Establishments.

Cooperative means an Entity that collectively markets or acquires goods or services on behalf of its members and that is subject to a tax regime in the jurisdiction in which it is located that is designed to ensure tax neutrality in respect of members' property or services sold through the cooperative and property or services acquired by members through the cooperative.

Covered Taxes is defined in Article 4.2.

Deductible Dividend means, with respect to a Constituent Entity that is subject to a Deductible Dividend Regime,

- (a) a distribution of profits to the holder of an Ownership Interest that is deductible from taxable income of the Constituent Entity under the laws of the jurisdiction in which it is located; or
- (b) a patronage dividend to a member of a Cooperative.

Deductible Dividend Regime means a tax regime designed to yield a single level of taxation on the owners of an Entity through a deduction from the income of the Entity for distributions of profits to the owners. For this purpose, patronage dividends of a Cooperative are treated as distributions to owners. A Deductible Dividend Regime also includes a regime applicable to Cooperatives that exempts the Cooperative from taxation.

Deemed Distribution Tax is defined in Article 7.3.2.

Deemed Distribution Tax Recapture Account means an account maintained in accordance with Article 7.3.3.

Departing Constituent Entity means a Constituent Entity that is subject to an election under Article 7.3.1 and that leaves the MNE Group or transfers substantially all of its assets to a person that is not a Constituent Entity of the same MNE Group located in the same jurisdiction.

Designated Filing Entity means the Constituent Entity, other than the Ultimate Parent Entity, that has been appointed by the MNE Group to file the GloBE Information Return on behalf of the MNE Group.

Designated Local Entity means the Constituent Entity of an MNE Group that is located in [insert name of implementing-Jurisdiction] and that has been appointed by the other Constituent Entities located in [insert name of implementing-Jurisdiction] of the MNE Group to file the GloBE Information Return, or to submit the notifications under Article 8.1.3.

Disallowed Accrual is defined in Article 4.4.6.

Disposition Recapture Ratio is defined in Article 7.3.8.

Disqualified Refundable Imputation Tax means any amount of Tax, other than a Qualified Imputation Tax, accrued or paid by a Constituent Entity that is:

- (a) refundable to the beneficial owner of a dividend distributed by such Constituent Entity in respect of that dividend or creditable by the beneficial owner against a tax liability other than a tax liability in respect of such dividend; or
- (b) refundable to the distributing corporation upon distribution of a dividend.

Dual-listed Arrangement means an arrangement entered into by two or more Ultimate Parent Entities of separate Groups, under which:

- (a) the Ultimate Parent Entities agree to combine their business by contract alone;
- (b) pursuant to contractual arrangements the Ultimate Parent Entities will make distributions (with respect to dividends and in liquidation) to their shareholders based on a fixed ratio;
- (c) their activities are managed as a single economic entity under contractual arrangements while retaining their separate legal identities;
- (d) the Ownership Interests in the Ultimate Parent Entities comprising the agreement are quoted, traded or transferred independently in different capital markets; and
- (e) the Ultimate Parent Entities prepare Consolidated Financial Statements in which the assets, liabilities, income, expenses and cash flows of all the Entities of the Groups are presented together as those of a single economic unit and that are required by a regulatory regime to be externally audited.

Effective Tax Rate (ETR) is defined in Article 5.1.1.

Election Year in respect of an Annual Election means the year for which the election is made.

Eligible Distribution Tax System means a corporate income tax system that

- (a) imposes an income tax on the corporation with the tax generally payable only when the corporation distributes profits to shareholders, is deemed to distribute profits to shareholders, or incurs certain non-business expenses;
- (b) imposes tax at a rate equal to or in excess of the Minimum Rate; and
- (c) was in force on or before 1 July 2021.

Eligible Employees means employees, including part-time employees, of a Constituent Entity that is a member of the MNE Group and independent contractors participating in the ordinary operating activities of the MNE Group under the direction and control of the MNE Group.

Eligible Payroll Costs means employee compensation expenditures (including salaries, wages, and other expenditures that provide a direct and separate personal benefit to the employee, such as health insurance and pension contributions), payroll and employment taxes, and employer social security contributions.

Eligible Tangible Assets is defined in Article 5.3.4.

Entity means:

- (a) any legal person (other than a natural person); or
- (b) an arrangement that prepares separate financial accounts, such as a partnership or trust.

ETR Adjustment Article means Article 3.2.6, Article 4.4.4, Article 4.6.1, Article 4.6.4, and Article 7.3.

Excess Profit is defined in Article 5.2.2.

Excluded Dividends means dividends or other distributions received or accrued in respect of an Ownership Interest, except for:

- (a) a Short-term Portfolio Shareholding, and
- (b) an Ownership Interest in an Investment Entity that is subject to an election under Article 7.6.

Excluded Entity is defined in Article 1.5.1 and Article 1.5.2.

Excluded Equity Gain or Loss means the gain, profit or loss included in the Financial Accounting Net Income or Loss of the Constituent Entity arising from:

- (a) gains and losses from changes in fair value of an Ownership Interest, except for a Portfolio Shareholding;
- (b) profit or loss in respect of an Ownership Interest included under the equity method of accounting; and
- (c) gains and losses from disposition of an Ownership Interest, except for a disposition of a Portfolio Shareholding.

Filing Constituent Entity is an Entity filing the GloBE Information Return in accordance with Article 8.1.

Financial Accounting Net Income or Loss is defined in Article 3.1.2.

Fiscal Year means an accounting period with respect to which the Ultimate Parent Entity of the MNE Group prepares its Consolidated Financial Statements. In the case of Consolidated Financial Statements as defined in paragraph (d) of its definition, Fiscal Year means the calendar year.

Five-Year Election means an election made by a Filing Constituent Entity with respect to a Fiscal Year (the election year) that cannot be revoked with respect to the election year or the four succeeding Fiscal Years. If a Five-Year Election is revoked with respect to a Fiscal Year (the revocation year), a new election cannot be made with respect to the four Fiscal Years succeeding the revocation year.

General Government means the central administration, agencies whose operations are under its effective control, state and local governments and their administrations.

GloBE Implementation Framework means the procedures to be developed by the Inclusive Framework on BEPS in order to develop administrative rules, guidance, and procedures that will facilitate the coordinated implementation of the GloBE Rules.

GloBE Income of all Constituent Entities is defined in Article 5.1.2(a)

GloBE Income or Loss of a Constituent Entity is defined in Article 3.1.1.

GloBE Information Return means that standardized return to be developed in accordance with the GloBE Implementation Framework that contains the information described in Article 8.1.4.

GloBE Loss Deferred Tax Asset is defined in Article 4.5.

GloBE Loss Election is defined in Article 4.5.1.

GloBE Losses of all Constituent Entities is defined in Article 5.1.2(b).

GloBE Reorganisation means a transformation or transfer of assets and liabilities such as in a merger, demerger, liquidation, or similar transaction where:

- (a) the consideration for the transfer is, in whole or in significant part, equity interests issued by the acquiring Constituent Entity or by a person connected with the acquiring Constituent Entity, or, in the case of a liquidation, equity interests of the target (or, when no consideration is provided, where the issuance of an equity interest would have no economic significance);
- (b) the disposing Constituent Entity's gain or loss on those assets is not subject to tax, in whole or in part; and
- (c) the tax laws of the jurisdiction in which the acquiring Constituent Entity is located require the acquiring Constituent Entity to compute taxable income after the disposition or acquisition using the disposing Constituent Entity's tax basis in the assets, adjusted for any Non-qualifying Gain or Loss on the disposition or acquisition.

GloBE Revenue is defined in Article 5.5.3(a) for the purposes of Article 5.5.2.

GloBE Rules means this set of rules as developed by the OECD/G20 Inclusive Framework on Base Erosion and Profit Shifting.

GloBE Safe Harbour means the exception provided in Article 8.2.1 to facilitate compliance by MNEs and administration by tax authorities. The conditions under which the Constituent Entities of an MNE Group located in a jurisdiction are eligible to the GloBE Safe Harbour will be established in accordance with a common and agreed process to be defined as part of the work undertaken by the Inclusive Framework on BEPS to develop the GloBE Implementation Framework.

Governmental Entity means an Entity that meets all of the following criteria set out in paragraphs (a) to (d) below:

- (a) it is part of or wholly-owned by a government (including any political subdivision or local authority thereof);
- (b) it has the principal purpose of:
 - (i) fulfilling a government function; or
 - (ii) managing or investing that government's or jurisdiction's assets through the making and holding of investments, asset management, and related investment activities for the government's or jurisdiction's assets;

and does not carry on a trade or business;

- (c) it is accountable to the government on its overall performance, and provides annual information reporting to the government; and
- (d) its assets vest in such government upon dissolution and to the extent it distributes net earnings, such net earnings are distributed solely to such government with no portion of its net earnings inuring to the benefit of any private person.

Group is defined in Article 1.2.2 and 1.2.3.

Group Entity, in respect of any Entity or Group, means an Entity that is a member of the same Group.

High-Tax Counterparty means a Constituent Entity that is located in a jurisdiction that is not a Low-Tax Jurisdiction or that is located in a jurisdiction that would not be a Low-Tax Jurisdiction if its ETR were determined without regard to any income or expense accrued by that Entity in respect of an Intragroup Financing Arrangement.

IFRS means the International Financial Reporting Standards.

IIR means the rules set out in Article 2.1 to Article 2.3.

Included Revaluation Method Gain or Loss means the net gain or loss, increased or decreased by any associated Covered Taxes, for the Fiscal Year in respect of all property, plant and equipment that arises under an accounting method or practice that:

- (a) periodically adjusts the carrying value of such property to its fair value;
- (b) records the changes in value in Other Comprehensive Income; and
- (c) does not subsequently report the gains or losses recorded in Other Comprehensive Income through profit and loss.

Insurance Investment Entity means an Entity that would meet the definition of an Investment Fund or a Real Estate Investment Vehicle except that it is established in relation to liabilities under an insurance or annuity contract and is wholly-owned by an Entity that is subject to regulation in its location as an insurance company.

Intermediate Parent Entity means a Constituent Entity (other than a Ultimate Parent Entity, Partially-Owned Parent Entity, Permanent Establishment, or Investment Entity) that owns (directly or indirectly) an Ownership Interest in another Constituent Entity in the same MNE Group.

International Organisation means any intergovernmental organisation (including a supranational organisation) or wholly-owned agency or instrumentality thereof that meets all of the criteria set out in paragraphs (a) to (c) below:

- (a) it is comprised primarily of governments;
- (b) it has in effect a headquarters or substantially similar agreement (for example, arrangements that entitle the organisation's offices or establishments in the jurisdiction (e.g. a subdivision, or a local, or regional office) to privileges and immunities) with the jurisdiction in which it is established; and
- (c) law or its governing documents prevent its income inuring to the benefit of private persons.

International Shipping Income is defined in Article 3.3.2.

Intragroup Financing Arrangement means any arrangement entered into between two or more members of the MNE Group whereby a High Tax Counterparty directly or indirectly provides credit or otherwise makes an investment in a Low Tax Entity.

Investment Entity means:

- (a) an Investment Fund or a Real Estate Investment Vehicle;
- (b) an Entity that is at least 95% owned directly by an Entity described in paragraph (a) or through a chain of such Entities and that operates exclusively or almost exclusively to hold assets or invest funds for the benefit of such Investment Entities; and
- (c) an Entity where at least 85% of the value of the Entity is owned by an Entity referred to in paragraph (a) provided that substantially all of the Entity's income is Excluded Dividends or

Excluded Equity Gain or Loss that is excluded from the computation of GloBE Income or Loss in accordance with Articles 3.2.1 (b) or (c).

Investment Fund means an Entity that meets all of the criteria set out in paragraphs (a) to (g) below:

- (a) it is designed to pool assets (which may be financial and non-financial) from a number of investors (some of which are not connected);
- (b) it invests in accordance with a defined investment policy;
- (c) it allows investors to reduce transaction, research, and analytical costs, or to spread risk collectively;
- (d) it is primarily designed to generate investment income or gains, or protection against a particular or general event or outcome;
- (e) investors have a right to return from the assets of the fund or income earned on those assets, based on the contributions made by those investors;
- (f) the Entity or its management is subject to a regulatory regime in the jurisdiction in which it is established or managed (including appropriate anti-money laundering and investor protection regulation); and
- (g) it is managed by investment fund management professionals on behalf of the investors.

Joint Venture (JV) means an Entity whose financial results are reported under the equity method in the Consolidated Financial Statements of the Ultimate Parent Entity provided that the Ultimate Parent Entity holds directly or indirectly at least 50% of its Ownership Interests. A Joint Venture does not include:

- (a) an Ultimate Parent Entity of an MNE Group that is subject to the GloBE Rules;
- (b) an Excluded Entity as defined by Article 1.5.1;
- (c) an Entity whose Ownership Interest held by the MNE Group are held directly through an Excluded Entity referred in Article 1.5.1 and the Entity:
 - (i) operates exclusively or almost exclusively to hold assets or invest funds for the benefit of its investors;
 - (ii) carries out activities that are ancillary to those carried out by the Excluded Entity; or
 - (iii) substantially all of its income is excluded from the computation of GloBE Income or Loss in accordance with Articles 3.2.1(b) and (c).
- (d) an Entity that is held by an MNE Group composed exclusively of Excluded Entities; or
- (e) a JV Subsidiary.

JV Group means a Joint Venture and its JV Subsidiaries.

JV Group Top-up Tax means the Ultimate Parent Entity's Allocable Share of the Top-up Tax of all members of the JV Group.

JV Subsidiary means an Entity whose assets, liabilities, income, expenses and cash flows are consolidated by a Joint Venture under an Acceptable Financial Accounting Standard (or would have been required had it been required to consolidate such items in accordance with an Acceptable Financial Accounting Standard). A Permanent Establishment whose Main Entity is the Joint Venture or a JV Subsidiary shall be treated as a separate JV Subsidiary.

Liable Constituent Entity (or Entities) means one or several Constituent Entities located in [insert name of implementing-Jurisdiction] that could be liable for Top-up Tax or subject to an adjustment under Chapter 2 if the GloBE Safe Harbour in Article 8.2.1 did not apply.

Local Tangible Asset means immovable property located in the same jurisdiction as the Constituent Entity.

Look-back Period in respect of an election under Article 3.2.6, means the Election Year and the four prior Fiscal Years.

Loss Year in respect of jurisdiction for which the Filing Constituent Entity has made an election under Article 3.2.6, means a Fiscal Year in the Lookback Period for which there is a Net Asset Loss for a Constituent Entity located in that jurisdiction and the total amount of Net Asset Loss of all such Constituent Entities exceeds the total amount of their Net Asset Gain.

Low-Taxed Constituent Entity means a Constituent Entity of the MNE Group that is located in a Low-Tax Jurisdiction or a Stateless Constituent Entity that, in respect of a Fiscal Year, has GloBE Income and is subject to an Effective Tax Rate (as determined under Chapter 5) in that Fiscal Year is lower than the Minimum Rate.

Low-Tax Entity means a Constituent Entity located in a Low Tax Jurisdiction or a jurisdiction that would be a Low-Tax Jurisdiction if the Effective Tax Rate for the jurisdiction were determined without regard to any income or expense accrued by that Entity in respect of an Intragroup Financing Arrangement.

Low-Tax Jurisdiction, in respect of an MNE Group in any Fiscal Year, means a jurisdiction where the MNE Group has Net GloBE Income and is subject to an Effective Tax Rate (as determined under Chapter 5) in that period that is lower than the Minimum Rate.

Main Entity, in respect of a Permanent Establishment, is the Entity that includes the Financial Accounting Net Income or Loss of the Permanent Establishment in its financial statements.

Material Competitive Distortion in respect of the application of a specific principle or procedure under a set of generally accepted accounting principles means an application that results in an aggregate variation greater than EUR 75 million in a Fiscal Year as compared to the amount that would have been determined by applying the corresponding IFRS principle or procedure. Where the application of a specific principle or procedure results in a Material Competitive Distortion, the accounting treatment of any item or transaction subject to that principle or procedure must be adjusted to conform to the treatment required for the item or transaction under IFRS in accordance with any Agreed Administrative Guidance.

Minimum Rate means fifteen percent (15%).

Minority-Owned Constituent Entity means a Constituent Entity where the Ultimate Parent Entity has a direct or indirect Ownership Interest in that Entity of 30% or less.

Minority-Owned Parent Entity means a Minority-Owned Constituent Entity that holds, directly or indirectly, the Controlling Interests of another Minority-Owned Constituent Entity, except where the Controlling Interests of the first-mentioned Entity are held, directly or indirectly, by another Minority-Owned Constituent Entity.

Minority-Owned Subgroup means a Minority-Owned Parent Entity and its Minority-Owned Subsidiaries.

Minority-Owned Subsidiary means a Minority-Owned Constituent Entity whose Controlling Interests are held, directly or indirectly, by a Minority-Owned Parent Entity.

MNE Group is defined in Articles 1.2.1.

MNE Group's Allocable Share of the Investment Entity's GloBE Income is defined in Article 7.4.4.

Multi-Parented MNE Group means two or more Groups where:

- (a) the Ultimate Parent Entities of those Groups enter into an arrangement that is a Stapled Structure or a Dual-listed Arrangement; and
- (b) at least one Entity or Permanent Establishment of the combined Group is located in a different

jurisdiction with respect to the location of the other Entities of the combined Group.

Net Asset Gain in respect of an election under Article 3.2.6, means the net gain from the disposition of Local Tangible Assets by a Constituent Entity located in the jurisdiction for which the election was made excluding the gain or loss on a transfer of assets to another Group Member.

Net Asset Loss in respect of a Constituent Entity and a Fiscal Year, means the net loss from the disposition of Local Tangible Assets by that Constituent Entity in that year excluding the gain or loss on a transfer of assets to another Group Member. The amount of Net Asset Loss shall be reduced by the amount of Net Asset Gain or Adjusted Asset Gain which is set-off against such loss pursuant to the application of Article 3.2.6(b) or (c) as a result of a previous election made under Article 3.2.6.

Net Book Value of Tangible Assets means the average of the beginning and end values of Tangible Assets after taking into account accumulated depreciation, depletion, and impairment, as recorded in the financial statements.

Net GloBE Income of a jurisdiction is defined in Article 5.1.2.

Net GloBE Loss of a jurisdiction is the nil or negative amount, if any, computed in accordance with the following formula:

$$\text{Net GloBE Loss} = \text{GloBE Income of all Constituent Entities} - \text{GloBE Losses of all Constituent Entities}$$

Where:

- (a) the GloBE Income of all Constituent Entities is the sum of the GloBE Income of all Constituent Entities located in the jurisdiction determined in accordance with Chapter 3 for the Fiscal Year; and
- (b) the GloBE Losses of all Constituent Entities is the sum of the GloBE Losses of all Constituent Entities located in the jurisdiction determined in accordance with Chapter 3 for the Fiscal Year.

Net Taxes Expense means the net amount of:

- (a) any Covered Taxes accrued as an expense and any current and deferred Covered Taxes included in the income tax expense, including Covered Taxes on income that is excluded from the GloBE Income or Loss computation;
- (b) any deferred tax asset attributable to a loss for the Fiscal Year;
- (c) any Qualified Domestic Minimum Top-up Tax accrued as an expense;
- (d) any taxes arising pursuant to the GloBE rules accrued as an expense; and
- (e) any Disqualified Refundable Imputation Tax accrued as an expense.

Non-profit Organisation means an Entity that meets all of the following criteria:

- (a) it is established and operated in its jurisdiction of residence:
 - (i) exclusively for religious, charitable, scientific, artistic, cultural, athletic, educational, or other similar purposes; or
 - (ii) as a professional organisation, business league, chamber of commerce, labour organisation, agricultural or horticultural organisation, civic league or an organisation operated exclusively for the promotion of social welfare;
- (b) substantially all of the income from the activities mentioned in paragraph (a) is exempt from income tax in its jurisdiction of residence;
- (c) it has no shareholders or members who have a proprietary or beneficial interest in its income or assets;

- (d) the income or assets of the Entity may not be distributed to, or applied for the benefit of, a private person or non-charitable Entity other than:
 - (i) pursuant to the conduct of the Entity's charitable activities;
 - (ii) as payment of reasonable compensation for services rendered or for the use of property or capital; or
 - (iii) as payment representing the fair market value of property which the Entity has purchased, and
- (e) upon termination, liquidation or dissolution of the Entity, all of its assets must be distributed or revert to a Non-profit Organisation or to the government (including any Governmental Entity) of the Entity's jurisdiction of residence or any political subdivision thereof;

but does not include any Entity carrying on a trade or business that is not directly related to the purposes for which it was established.

Non-Qualified Refundable Tax Credit means a tax credit that is not a Qualified Refundable Tax Credit but that is refundable in whole or in part.

Non-qualifying Gain or Loss means the lesser of the gain or loss of the disposing Constituent Entity arising in connection with a GloBE Reorganisation that is subject to tax in the disposing Constituent Entity's location and the financial accounting gain or loss arising in connection with the GloBE Reorganisation.

Number of Employees, for the purposes of the UTPR percentage, means the total number of employees on a full-time equivalent (FTE) basis of all the Constituent Entities resident for tax purposes in the relevant tax jurisdiction. For this purpose, independent contractors participating in the ordinary operating activities of the Constituent Entity are reported as employees. With regard to Permanent Establishments, employees should be allocated to the tax jurisdiction in which the Permanent Establishment is located when the payroll costs of such employees are included in the separate financial accounts of that Permanent Establishment as determined by Article 3.4.1 and adjusted in accordance with 3.4.2. The Number of Employees attributed to the tax jurisdiction of a Permanent Establishment shall not be taken into account for the Number of Employees of the tax jurisdiction of the Main Entity.

OECD Model Tax Convention means the OECD (2017), Model Tax Convention on Income and on Capital: Condensed Version 2017, OECD Publishing, Paris, https://doi.org/10.1787/mtc_cond-2017-en.

Other Comprehensive Income means items of income and expense that are not recognised in profit or loss as required or permitted by the Authorised Financial Accounting Standard used in the Consolidated Financial Statements. Other Comprehensive Income is usually reported as an adjustment to equity in the statement of financial position (balance sheet).

Ownership Interest means any equity interest that carries rights to the profits, capital or reserves of an Entity, including the profits, capital or reserves of a Main Entity's Permanent Establishment(s).

Parent Entity means an Ultimate Parent Entity that is not an Excluded Entity, an Intermediate Parent Entity, or a Partially-Owned Parent Entity.

Parent Entity's Inclusion Ratio is defined in Article 2.2.2.

Partially-Owned Parent Entity means a Constituent Entity (other than a Ultimate Parent Entity, Permanent Establishment, or Investment Entity) that:

- (a) owns (directly or indirectly) an Ownership Interest in another Constituent Entity of the same MNE Group; and
- (b) has more than 20% of the Ownership Interests in its profits held directly or indirectly by persons that are not Constituent Entities of the MNE Group.

Passive Income means income included in GloBE Income that is:

- (a) a dividend or dividend equivalents;
- (b) interest or interest equivalent;
- (c) rent;
- (d) royalty;
- (e) annuity; or
- (f) net gains from property of a type that produces income described in paragraphs (a) to (e),

but only to the extent a Constituent Entity-owner is subject to tax on such income under a Controlled Foreign Company Tax Regime or as a result of an Ownership Interest in a Hybrid Entity.

Pension Fund means:

- (a) an Entity that is established and operated in a jurisdiction exclusively or almost exclusively to administer or provide retirement benefits and ancillary or incidental benefits to individuals:
 - i. regulated as such by that jurisdiction or one of its political subdivisions or local authorities; or
 - ii. those benefits are secured or otherwise protected by national regulations and funded by a pool of assets held through a fiduciary arrangement or trustor to secure the fulfilment of the corresponding pension obligations against a case of insolvency of the MNE Group; and
- (b) a Pension Services Entity.

Pension Services Entity means an Entity that is established and operated exclusively or almost exclusively:

- (a) to invest funds for the benefit of Entities referred to in paragraph (a) of the definition of Pension Fund; or
- (b) to carry out activities that are ancillary to those regulated activities carried out by the Entities referred to in paragraph (a) of the definition of Pension Fund provided that they are members of the same Group.

Permanent Establishment means:

- (a) a place of business (including a deemed place of business) situated in a jurisdiction and treated as a permanent establishment in accordance with an applicable Tax Treaty in force provided that such jurisdiction taxes the income attributable to it in accordance with a provision similar to Article 7 of the OECD Model Tax Convention on Income and on Capital;
- (b) if there is no applicable Tax Treaty in force, a place of business (including a deemed place of business) in respect of which a jurisdiction taxes under its domestic law the income attributable to such place of business on a net basis similar to the manner in which it taxes its own tax residents;
- (c) if a jurisdiction has no corporate income tax system, a place of business (including a deemed place of business) situated in that jurisdiction that would be treated as a permanent establishment in accordance with the OECD Model Tax Convention on Income and on Capital provided that such jurisdiction would have had the right to tax the income attributable to it in accordance with Article 7 of that model; or
- (d) a place of business (or a deemed place of business) that is not already described in

paragraphs (a) to (c) through which operations are conducted outside the jurisdiction where the Entity is located provided that such jurisdiction exempts the income attributable to such operations.

Policy Disallowed Expenses means:

- (a) expenses accrued by the Constituent Entity for illegal payments, including bribes and kickbacks; and
- (b) expenses accrued by the Constituent Entity for fines and penalties that equal or exceed EUR 50 000 (or an equivalent in the functional currency in which the Constituent Entity's Financial Accounting Net Income or Loss was calculated).

Portfolio Shareholding means Ownership Interests in an Entity that are held by the MNE Group and that carry rights to less than 10% of the profits, capital, reserves, or voting rights of that Entity at the date of the distribution or disposition.

Prior Period Errors and Changes in Accounting Principles means all changes in the opening equity at the beginning of the Fiscal Year of a Constituent Entity attributable to:

- (a) a correction of an error in the determination of Financial Accounting Net Income in a previous Fiscal Year that affected the income or expenses includible in the computation of GloBE Income or Loss for such Fiscal Year, except to the extent such error correction resulted in a material decrease to a liability for Covered Taxes subject to Article 4.6; or
- (b) a change in accounting principle or policy that affects income or expenses includible in the computation of GloBE Income or Loss.

Qualified Ancillary International Shipping Income is defined in Article 3.3.3.

Qualified Domestic Minimum Top-up Tax means a minimum tax that is included in the domestic law of a jurisdiction and that:

- (a) determines the Excess Profits of the Constituent Entities located in the jurisdiction (domestic Excess Profits) in a manner that is equivalent to the GloBE Rules;
- (b) operates to increase domestic tax liability with respect to domestic Excess Profits to the Minimum Rate for the jurisdiction and Constituent Entities for a Fiscal Year; and
- (c) is implemented and administered in a way that is consistent with the outcomes provided for under the GloBE Rules and the Commentary, provided that such jurisdiction does not provide any benefits that are related to such rules.

A Qualified Domestic Minimum Top-up Tax may compute domestic Excess Profits based on an Acceptable Financial Accounting Standard permitted by the Authorised Accounting Body or an Authorised Financial Accounting Standard adjusted to prevent any Material Competitive Distortions, rather than the financial accounting standard used in the Consolidated Financial Statements.

Qualified IIR means a set of rules equivalent to Article 2.1 to Article 2.3 of the GloBE Rules (including any provisions of the GloBE Rules associated with those articles) that are included in the domestic law of a jurisdiction and that are implemented and administered in a way that is consistent with the outcomes provided for under the GloBE Rules and the Commentary provided that such jurisdiction does not provide any benefits that are related to such rules.

Qualified Imputation Tax means a Covered Tax accrued or paid by a Constituent Entity that is refundable or creditable to the beneficial owner of a dividend distributed by such Constituent Entity (or, in the case of a Covered Tax accrued or paid by a Permanent Establishment, a dividend distributed by the Main Entity) to the extent that the refund is payable, or the credit is provided:

- (a) by a jurisdiction other than the jurisdiction which imposed the Covered Taxes under a foreign tax credit regime;
- (b) to a beneficial owner of the dividend that is subject to tax at a nominal rate that equals or exceeds the Minimum Rate on the dividend on a current basis under the domestic law of the jurisdiction which imposed the Covered Taxes on the Constituent Entity;
- (c) to an individual beneficial owner of the dividend who is tax resident in the jurisdiction which imposed the Covered Taxes on the Constituent Entity and who is subject to tax on the dividends as ordinary income; or
- (d) to a Governmental Entity, an International Organisation, a resident Non-profit Organisation, a resident Pension Fund, a resident Investment Entity that is not a Group Entity, or a resident life insurance company to the extent that the dividends are received in connection with a pension fund business and subject to tax in a similar manner as a dividend received by Pension Fund.

For purposes of paragraph (d), a Non-Profit Organisation or Pension Fund is resident in a jurisdiction if it is created and managed in that jurisdiction, and an Investment Entity is resident in a jurisdiction if it is created and regulated in the jurisdiction. A life insurance company is resident in the jurisdiction in which it is located.

Qualified Refundable Tax Credit means a refundable tax credit designed in a way such that it must be paid as cash or available as cash equivalents within four years from when a Constituent Entity satisfies the conditions for receiving the credit under the laws of the jurisdiction granting the credit. A tax credit that is refundable in part is a Qualified Refundable Tax Credit to the extent it must be paid as cash or available as cash equivalents within four years from when a Constituent Entity satisfies the conditions for receiving the credit under the laws of the jurisdiction granting the credit. A Qualified Refundable Tax Credit does not include any amount of tax creditable or refundable pursuant to a Qualified Imputation Tax or a Disqualified Refundable Imputation Tax.

Qualified UTPR means a set of rules equivalent to Article 2.4 to Article 2.6 of the GloBE Rules (including any provisions of the GloBE Rules associated with those articles) that are included in the domestic law of a jurisdiction and that are implemented and administered in a way that is consistent with the outcomes provided for under the GloBE Rules and the Commentary provided that such jurisdiction does not provide any benefits that are related to such rules.

Qualifying Competent Authority Agreement means a bilateral or multilateral agreement or arrangement between Competent Authorities that provides for the automatic exchange of annual GloBE Information Returns.

Real Estate Investment Vehicle means an Entity the taxation of which achieves a single level of taxation either in its hands or the hands of its interest holders (with at most one year of deferral), provided that that person holds predominantly immovable property and is itself widely held.

Recaptured Deferred Tax Liability is defined in Article 4.4.4.

Recapture Exception Accrual is defined in Article 4.4.5.

Reductions to Covered Taxes is defined in Article 4.1.3.

Reference Jurisdiction is defined in Article 9.3.3.

Reporting Fiscal Year means the Fiscal Year that is the subject of the GloBE Information Return.

Short-term Portfolio Shareholding means a Portfolio Shareholding that has been economically held by the Constituent Entity that receives or accrues the dividends or other distributions for less than one year at the date of the distribution.

Stapled Structure means an arrangement entered into by two or more Ultimate Parent Entities of separate Groups, under which:

- (a) 50% or more of the Ownership Interests in the Ultimate Parent Entities of the separate Groups are by reason of form of ownership, restrictions on transfer, or other terms or conditions combined with each other, and cannot be transferred or traded independently. If the combined Ownership Interests are listed, they are quoted at a single price; and
- (b) one of those Ultimate Parent Entities prepares Consolidated Financial Statements in which the assets, liabilities, income, expenses and cash flows of all the Entities of the Groups are presented together as those of a single economic unit and that are required by a regulatory regime to be externally audited.

Stateless Constituent Entity means a Constituent Entity described in Article 10.3.2(b) and Article 10.3.3(d).

Substance-based Income Exclusion is defined in Article 5.3.

Tangible Assets, for the purposes of the UTPR percentage and for Article 9.3, means the Tangible Assets of all the Constituent Entities resident for tax purposes in the relevant tax jurisdiction. Tangible Assets do not include cash or cash equivalents, intangibles, or financial assets. With regard to Permanent Establishments, Tangible Assets should be allocated to the tax jurisdiction in which the Permanent Establishment is located provided those Tangible Assets are included in the separate financial accounts of that Permanent Establishment as determined by Article 3.4.1 and adjusted in accordance with Article 3.4.2. The Tangible Assets allocated to the tax jurisdiction of a Permanent Establishment shall not be taken into account for the Tangible Assets of the tax jurisdiction of the Main Entity.

Tax means a compulsory unrequited payment to General Government.

Taxable Distribution Method is defined in Article 7.6.2.

Tax Treaty means an agreement for the avoidance of double taxation with respect to taxes on income and on capital.

Tested Year is defined in Article 7.6.5.

Testing Period is defined in Article 7.6.5.

Top-up Tax means the top-up tax computed for the jurisdiction or Constituent Entity pursuant to Article 5.2.

Top-up Tax Percentage is defined in Article 5.2.1.

Total Deferred Tax Adjustment Amount is defined in Article 4.4.1.

Total UTPR Top-up Tax Amount means the total amount of Top-up Tax that is allocable under the UTPR as defined in Article 2.4.1.

Transition Year, for a jurisdiction, means the first Fiscal Year that the MNE Group comes within the scope of the GloBE Rules in respect of that jurisdiction.

Ultimate Parent Entity (UPE) is defined in Article 1.4.

Undistributed Net GloBE Income is defined in Article 7.6.3.

UPE Jurisdiction means the jurisdiction where the Ultimate Parent Entity is located.

UTPR means the rules set out in Article 2.4 to Article 2.6.

UTPR Jurisdiction means a jurisdiction that has a Qualified UTPR in force.

UTPR Percentage means the percentage of Total UTPR Top-up Tax Amount that is allocated to a UTPR Jurisdiction in accordance with the formula provided in 2.6.1.

UTPR Top-up Tax Amount means the amount of Top-up Tax allocated to a UTPR Jurisdiction under the UTPR.

Article 10.2. Definitions of Flow-through Entity, Tax Transparent Entity, Reverse Hybrid Entity, and Hybrid Entity

10.2.1. An Entity is a **Flow-through Entity** to the extent it is fiscally transparent with respect to its income, expenditure, profit or loss in the jurisdiction where it was created unless it is tax resident and subject to a Covered Tax on its income or profit in another jurisdiction.

- (a) A Flow-Through Entity is a **Tax Transparent Entity** with respect to its income, expenditure, profit or loss to the extent that it is fiscally transparent in the jurisdiction in which its owner is located.
- (b) A Flow-Through Entity is a **Reverse Hybrid Entity** with respect to its income, expenditure, profit or loss to the extent that it is not fiscally transparent in the jurisdiction in which the owner is located.

10.2.2. An Entity is treated as fiscally transparent under the laws of a jurisdiction, if that jurisdiction treats the income, expenditure, profit or loss of that Entity as if it were derived or incurred by the direct owner of that Entity in proportion to its interest in that Entity.

10.2.3. An Ownership Interest in an Entity or a Permanent Establishment that is a Constituent Entity shall be treated as held through a **Tax Transparent Structure** if that Ownership Interest is held indirectly through a chain of Tax Transparent Entities.

10.2.4. A Constituent Entity that is not a tax resident and not subject to a Covered Tax or a Qualified Domestic Minimum Top-up Tax based on its place of management, place of creation, or similar criteria shall be treated as a Flow-Through Entity and a Tax Transparent Entity in respect of its income, expenditure, profit or loss to the extent that:

- (a) its owners are located in a jurisdiction that treats the Entity as fiscally transparent;
- (b) it does not have a place of business in the jurisdiction where it was created; and
- (c) the income, expenditure, profit or loss is not attributable to a Permanent Establishment.

10.2.5. An Entity that is treated as a separate taxable person for income tax purposes in the jurisdiction where it is located is a **Hybrid Entity** with respect to its income, expenditure, profit or loss to the extent that it is fiscally transparent in the jurisdiction in which its owner is located.

Article 10.3. Location of an Entity and a Permanent Establishment

10.3.1. The location of an Entity that is not a Flow-through Entity is determined as follows:

- (a) if it is a tax resident in a jurisdiction based on its place of management, place of creation or similar criteria, it is located in that jurisdiction; and
- (b) in other cases, it is located in the jurisdiction in which it was created.

10.3.2. The location of an Entity that is a Flow-through Entity is determined as follows:

- (a) if it is the Ultimate Parent Entity of the MNE Group or it is required to apply an IIR in accordance with Article 2.1, it is located in the jurisdiction where it was created; and
- (b) in other cases, it shall be treated as a stateless Entity.

10.3.3. The location of a Permanent Establishment is determined as follows:

- (a) if it is described in paragraph (a) of the definition in Article 10.1, is located in the jurisdiction where it is treated as a permanent establishment and is taxed under the applicable Tax Treaty in force;
- (b) if it is described in paragraph (b) of the definition in Article 10.1, is located in the jurisdiction where it is subject to net basis taxation based on its business presence;
- (c) if it is described in paragraph (c) of the definition in Article 10.1, is located in the jurisdiction where it is situated; and
- (d) if it is described in paragraph (d) of the definition in Article 10.1, is considered as a stateless Permanent Establishment.

10.3.4. Where by reason of Article 10.3.1, a Constituent Entity is located in more than one jurisdiction (a dual-located Entity), then its status for purposes of the GloBE Rules shall be determined as follows:

- (a) if it is located in two jurisdictions that have an applicable Tax Treaty in force:
 - (i) it shall be located in the jurisdiction where it is considered as a deemed resident for purposes of the Tax Treaty;
 - (ii) if the Tax Treaty requires the competent authorities to reach a mutual agreement on the deemed residence of the Constituent Entity for purposes of the Tax Treaty and no agreement exists, then paragraph (b) shall apply;
 - (iii) if the Tax Treaty does not provide relief or exemption from tax because the Constituent Entity is a tax resident of both Contracting Parties, then paragraph (b) shall apply;
- (b) if no Tax Treaty applies, then its location shall be determined as follows:
 - (i) it shall be located in the jurisdiction where it paid the greater amount of Covered Taxes for the Fiscal Year, without considering the ones paid in accordance with a Controlled Foreign Company Tax Regime;
 - (ii) if the amount of Covered Taxes paid in both jurisdiction is the same or zero, it shall be located in the jurisdiction where it has the greater amount of Substance-based Income Exclusion computed on an entity basis in accordance with Article 5.3;
 - (iii) if the amount of the Substance-based Income Exclusion in both jurisdictions is the same or zero, then it is considered a Stateless Constituent Entity unless it is the Ultimate Parent Entity of the MNE Group in which case it shall be located in the jurisdiction where it was created.

10.3.5. Where, under Article 10.3.4, a dual-located Entity that is a Parent Entity is located in a jurisdiction where it is not subject to a Qualified IIR, then the other jurisdiction can require such Entity to apply its Qualified IIR unless it is restricted by an applicable Tax Treaty in force.

10.3.6. Where an Entity has changed its location during the Fiscal Year, it shall be located in the jurisdiction where it was located at the beginning of that year.

Tax Challenges Arising from the Digitalisation of the Economy – Global Anti-Base Erosion Model Rules (Pillar Two)

INCLUSIVE FRAMEWORK ON BEPS

A key part of the OECD/G20 BEPS Project is addressing the tax challenges arising from the digitalisation of the economy. In October 2021, over 135 jurisdictions joined a ground breaking plan to update key elements of the international tax system which is no longer fit for purpose in a globalised and digitalised economy. The Global Anti-Base Erosion Rules (GloBE) are a key component of this plan and ensure large multinational enterprise pay a minimum level of tax on the income arising in each of the jurisdictions where they operate. More specifically, the GloBE Rules provide for a co-ordinated system of taxation that imposes a top-up tax on profits arising in a jurisdiction whenever the effective tax rate, determined on a jurisdictional basis, is below the minimum rate. This report delineates the scope and sets out the operative provisions and definitions of the GloBE Rules. These rules are intended to be implemented as part of a common approach and to be brought into domestic legislation as from 2022.



For more information:

 ctp.contact@oecd.org

 www.oecd.org/tax/beps

 @OECDtax

 OECD Tax

OECD/G20 BASE EROSION AND PROFIT SHIFTING PROJECT

Tax Challenges Arising from the Digitalisation of the Economy – Commentary to the Global Anti-Base Erosion Model Rules (Pillar Two)

INCLUSIVE FRAMEWORK ON BEPS



OECD/G20 Base Erosion and Profit Shifting Project

**Tax Challenges Arising from the
Digitalisation of the Economy –
Commentary to the Global Anti-Base Erosion
Model Rules (Pillar Two)**

Inclusive Framework on BEPS



This document and any map included herein are without prejudice to the status of or sovereignty over any territory, to the delimitation of international frontiers and boundaries and to the name of any territory, city or area.

Please cite this document as:

OECD (2022), *Tax Challenges Arising from the Digitalisation of the Economy – Commentary to the Global Anti-Base Erosion Model Rules (Pillar Two)*, OECD, Paris, <https://www.oecd.org/tax/beps/tax-challenges-arising-from-the-digitalisation-of-the-economy-global-anti-base-erosion-model-rules-pillar-two-commentary.pdf>.

Photo credits: Cover © ninog – Fotolia.com.

© OECD 2022

The use of this work, whether digital or print, is governed by the Terms and Conditions to be found at www.oecd.org/termsandconditions

Foreword

Digitalisation and globalisation have had a profound impact on economies and the lives of people around the world, and this impact has only accelerated in the 21st century. These changes have brought with them challenges to the rules for taxing international business income, which have prevailed for more than a hundred years and created opportunities for base erosion and profit shifting (BEPS), requiring bold moves by policy makers to restore confidence in the system and ensure that profits are taxed where economic activities take place and value is created.

In 2013, the OECD ramped up efforts to address these challenges in response to growing public and political concerns about tax avoidance by large multinationals. The OECD and G20 countries joined forces and developed an Action Plan to address BEPS in September 2013. The Action Plan identified 15 actions aimed at introducing coherence in the domestic rules that affect cross-border activities, reinforcing substance requirements in the existing international standards, and improving transparency as well as certainty.

After two years of work, measures in response to the 15 actions, including those published in an interim form in 2014, were consolidated into a comprehensive package and delivered to G20 Leaders in November 2015. The BEPS package represents the first substantial renovation of the international tax rules in almost a century. As the BEPS measures are implemented, it is expected that profits will be reported where the economic activities that generate them are carried out and where value is created. BEPS planning strategies that rely on outdated rules or on poorly co-ordinated domestic measures will be rendered ineffective-

OECD and G20 countries also agreed to continue to work together to ensure a consistent and co-ordinated implementation of the BEPS recommendations and to make the project more inclusive. As a result, they created the OECD/G20 Inclusive Framework on BEPS (Inclusive Framework), bringing all interested and committed countries and jurisdictions on an equal footing in the Committee on Fiscal Affairs and its subsidiary bodies. With over 140 members, the Inclusive Framework monitors and peer reviews the implementation of the minimum standards and is completing the work on standard setting to address BEPS issues. In addition to its members, other international organisations and regional tax bodies are involved in the work of the Inclusive Framework, which also consults business and the civil society on its different work streams.

Although implementation of the BEPS package is dramatically changing the international tax landscape and improving the fairness of tax systems, one of the key outstanding BEPS issues – to address the tax challenges arising from the digitalisation of the economy – remained unresolved. In a major step forward on 8 October 2021, over 135 Inclusive Framework members, representing more than 95% of global GDP, joined a two-pillar solution to reform the international taxation rules and ensure that multinational enterprises pay a fair share of tax wherever they operate and generate profits in today's digitalised and globalised world economy. The implementation of these new rules is envisaged by 2023.

This document was approved by the OECD/G20 Inclusive Framework on BEPS on 11 March 2022 and prepared for publication by the OECD Secretariat.

Table of contents

| | |
|--|-----------|
| Foreword | 3 |
| Table of contents | 3 |
| Abbreviations and acronyms | 7 |
| Introduction | 8 |
| References | 13 |
| 1 Scope | 14 |
| Article 1.1 - Scope of GloBE Rules | 14 |
| Article 1.2 - MNE Group and Group | 16 |
| Article 1.3 - Constituent Entity | 18 |
| Article 1.4 - Ultimate Parent Entity | 19 |
| Article 1.5 - Excluded Entity | 20 |
| References | 23 |
| 2 Charging Provisions | 24 |
| Overview of the IIR | 24 |
| Article 2.1 - Application of the IIR | 26 |
| Article 2.2 - Allocation of Top-up Tax under the IIR | 28 |
| Article 2.3 - IIR Offset Mechanism | 31 |
| Overview of the UTPR | 31 |
| Article 2.4 - Application of the UTPR | 32 |
| Article 2.5 - UTPR Top-up Tax Amount | 36 |
| Article 2.6 - Allocation of Top-up Tax for the UTPR | 39 |
| Notes | 42 |
| 3 Computation of GloBE Income or Loss | 43 |
| Article 3.1 - Financial Accounts | 43 |
| Article 3.2 - Adjustments to determine GloBE Income or Loss | 46 |
| Article 3.3 - International shipping income exclusion | 70 |
| Article 3.4 - Allocation of Income or Loss between a Main Entity and a Permanent Establishment | 77 |
| Article 3.5 - Allocation of Income or Loss from a Flow-through Entity | 79 |
| References | 84 |
| Notes | 84 |

| | |
|--|------------|
| 4 Computation of Adjusted Covered Taxes | 85 |
| Article 4.1 - Adjusted Covered Taxes | 85 |
| Article 4.2 - Definition of Covered Taxes | 91 |
| Article 4.3 - Allocation of Covered Taxes from one Constituent Entity to another Constituent Entity | 95 |
| Article 4.4 - Mechanism to address temporary differences | 100 |
| Article 4.5 - The GloBE Loss Election | 109 |
| Article 4.6 - Post-filing Adjustments and Tax Rate Changes | 111 |
| References | 114 |
| Notes | 114 |
| 5 Computation of Effective Tax Rate and Top-up Tax | 115 |
| Article 5.1 - Determination of Effective Tax Rate | 115 |
| Article 5.2 - Top-up Tax | 117 |
| Article 5.3 - Substance-based Income Exclusion | 119 |
| Article 5.4 - Additional Current Top-up Tax | 127 |
| Article 5.5 - De minimis exclusion | 129 |
| Article 5.6 - Minority-Owned Constituent Entities | 134 |
| References | 136 |
| Notes | 136 |
| 6 Corporate Restructurings and Holding Structures | 137 |
| Overview | 137 |
| Article 6.1 - Application of Consolidated Revenue Threshold to Group Mergers and Demergers | 140 |
| Article 6.2 - Constituent Entities joining and leaving an MNE Group | 144 |
| Article 6.3 - Transfer of Assets and Liabilities | 150 |
| Article 6.4 - Joint Ventures | 152 |
| Article 6.5 - Multi-Parented MNE Groups | 154 |
| References | 158 |
| Notes | 158 |
| 7 Tax neutrality and distribution regimes | 159 |
| Article 7.1 - Ultimate Parent Entity that is a Flow-through Entity | 159 |
| Article 7.2 - Ultimate Parent Entity subject to Deductible Dividend Regime | 164 |
| Article 7.3 - Eligible Distribution Tax Systems | 167 |
| Article 7.4 - Effective Tax Rate Computation for Investment Entities | 171 |
| Article 7.5 - Investment Entity Tax Transparency Election | 173 |
| Article 7.6 - Taxable Distribution Method Election | 175 |
| Notes | 178 |
| 8 Administration | 179 |
| Article 8.1 - Filing obligation | 179 |
| Article 8.2 - Safe Harbours | 184 |
| Article 8.3 - Administrative Guidance | 186 |
| 9 Transition rules | 187 |
| Article 9.1 - Tax Attributes Upon Transition | 187 |
| Article 9.2 - Transitional relief for the Substance-based Income Exclusion | 189 |
| Article 9.3 - Exclusion from the UTPR of MNE Groups in the initial phase of their international activity | 189 |

| | |
|---|------------|
| Article 9.4 - Transitional relief for filing obligations | 192 |
| 10 Definitions | 193 |
| Article 10.1 - Defined Terms | 193 |
| Article 10.2 - Definitions of Flow-through Entity, Tax Transparent Entity, Reverse Hybrid Entity, and Hybrid Entity | 217 |
| Article 10.3 - Location of an Entity and a Permanent Establishment | 220 |
| References | 225 |
| Notes | 226 |

Abbreviations and acronyms

| | |
|--------------|--|
| BEPS | Base Erosion and Profit Shifting |
| CbC | Country-by-Country |
| CbCR | CbC Reporting |
| CFC | Controlled foreign company |
| CIT | Corporate income tax |
| ETR | Effective tax rate |
| FX | Foreign exchange |
| FXGL | Foreign currency gains or losses |
| GAAP | General accepted accounting principles |
| GloBE | Global Anti-Base Erosion |
| IAS | International Accounting Standards |
| IFRS | International Financial Reporting Standards |
| IIR | Income Inclusion Rule |
| JV(s) | Joint Venture(s) |
| LTCE | Low-Taxed Constituent Entity |
| MNE | Multinational Enterprise |
| OCI | Other comprehensive income |
| OECD | Organization for Economic Co-operation and Development |
| PE | Permanent Establishment |
| POPE | Partially-Owned Parent Entity |
| UPE | Ultimate Parent Entity |

Introduction

1. The Global Base Erosion rules (GloBE Rules) have been developed as part of the solution for addressing the tax challenges of the digital economy. They are designed to ensure large multinational enterprises (MNEs) pay a minimum level of tax on the income arising in each jurisdiction where they operate. The GloBE Rules are intended to be implemented as part of a common approach. A jurisdiction that joins the common approach is not required to adopt the GloBE Rules but, if it chooses to do so, it agrees to implement and administer them in a way that is consistent with the outcome provided under the GloBE Rules and the commentary on the GloBE Rules (including the agreement as to rule order). Consistency in the implementation and administration of the GloBE Rules is intended to result in a transparent and comprehensive system of taxation that provides predictable outcomes for MNEs and avoids the risk of double or over-taxation.

2. The GloBE Rules apply a system of Top-up Taxes – that is, an IIR and a UTPR – that brings the total amount of taxes paid on an MNE’s Excess Profit in a jurisdiction up to the Minimum Rate. This Top-up Tax does not operate as a typical direct tax on income of an Entity. Rather it applies to the Excess Profits calculated on a jurisdictional basis and only applies to the extent those profits are subject to tax in a given year below the Minimum Rate. Rather than a typical direct tax on income, the tax imposed under the GloBE Rules is closer in design to an international alternative minimum tax, that uses standardised base and tax calculation mechanics to identify pools of low-taxed income within an MNE Group and imposes a co-ordinated tax charge that brings the Group’s ETR on that income in each jurisdiction up to the Minimum Rate. The design of the GloBE Rules as a Top-up Tax facilitates the co-ordinated application of the GloBE Rules by ensuring that the aggregate amount of incremental tax payable under the rules in each jurisdiction does not cause the ETR to exceed the Minimum Rate. The design of the IIR and UTPR as Top-up Taxes, however, does not restrict a jurisdiction from legislating those rules under a corporate income tax system in its domestic law.

3. These GloBE Rules are drafted in the form of model rules in order to provide jurisdictions with a template for domestic implementation. This Commentary provides tax administrations and taxpayers with guidance on the interpretation and application of those rules. The Commentary is intended to promote a consistent and common interpretation of the GloBE Rules that will facilitate co-ordinated outcomes for both tax administrations and MNE Groups. The Commentary explains the intended outcomes under the rules and clarifies the meaning of certain terms. It also includes examples which illustrate the application of the rules to certain fact patterns. The Inclusive Framework may develop further examples on the application of the rules through Administrative Guidance provided under Article 8.3. A breakdown of the contents of each Chapter is set out below.

Scope

4. Chapter 1 sets out the scope of the GloBE Rules. The GloBE Rules will apply to the Constituent Entities of an MNE Group that meets the consolidated revenue threshold as set out in Article 1.1. Article 1.1

is modified by Article 6.1 which sets out further rules clarifying the application of the consolidated revenue threshold in the case of mergers and de-mergers.

Charging provisions

5. Chapter 2 contains the operating mechanics for the IIR and the UTPR. The IIR is the primary rule that is applied by a Parent Entity within the MNE Group to that Parent Entity's Allocable Share of Top-up Tax of any LTCE. The IIR incorporates a top-down approach which ensures priority in the application of the IIR is given to the Parent Entity at the highest point in the ownership chain. Under this approach, an Intermediate Parent Entity shall not apply the IIR where it is controlled by another parent entity further up the ownership chain that is subject to a Qualified IIR. However, the top-down approach has some exceptions (e.g., split-ownership rules). In order to avoid double taxation in these cases, the IIR includes an offset mechanism that allows the Parent Entity to reduce the Top-up Tax otherwise payable under the IIR where that tax is brought into charge by another Parent Entity.

6. The UTPR operates as a backstop to the IIR, applying only in specific circumstances where the Top-up Tax is not brought into charge under an IIR. The application of a UTPR in a UTPR Jurisdiction shall result in that jurisdiction imposing an additional cash tax expense on the Constituent Entities of an MNE Group that is equal to the UTPR Top-up Tax Amount. Chapter 2 sets out the rules for calculating the UTPR Top-up Tax Amount for each Low-Tax Jurisdiction and the mechanism used to allocate the UTPR Top-up Tax Amount to a UTPR Jurisdiction.

Calculating ETR on a jurisdictional basis

7. Chapter 3 sets out the mechanics for calculating a Constituent Entity's GloBE Income or Loss. The starting point for this calculation is the financial accounting net income or loss determined for the Constituent Entity in the preparation of the Consolidated Financial Statements for the Fiscal Year. The GloBE Rules use the Entity's financial accounting net income or loss as the starting point for determining GloBE Income or Loss because it provides a uniform measure of income that can be applied in all jurisdictions. Moreover, because it draws on information already used in the preparation of Consolidated Financial Statements, it reduces the MNE Group's compliance costs. In order to account for certain permanent differences between accounting and the GloBE tax base, the GloBE Rules then adjust this amount to arrive at that Entity's GloBE Income or Loss. Chapter 3 further includes mechanisms for allocating income between a Main Entity and a PE and between a tax transparent entity and its owners. The exclusion for International Shipping Income set out in Article 3.3 provides an exclusion for income derived from international shipping based on the scope of Article 8 of the OECD Model Tax Convention (OECD, 2017^[1]).

8. Chapter 4 sets out the mechanics for determining the amount of Covered Taxes on the GloBE income of each Constituent Entity. The Covered Tax calculation is done in a number of steps. The first step takes the current taxes determined for the Constituent Entity for the Fiscal Year and then adjusted this amount to arrive at that Entity's Adjusted Covered Taxes. These adjustments include adjustments based on the principles of deferred tax accounting to address differences in the timing of the recognition of income and expense. The GloBE Rules include deferred tax accounting adjustments to the current tax amount to prevent permanent differences in the GloBE tax liability from arising solely due to timing differences. The GloBE Rules rely on deferred tax accounting principles to address timing differences because they address timing issues as they arise and in a more targeted and refined manner than other approaches, such as carry-forwards. This approach also reduces compliance costs because it draws on information and accounting systems the MNE Group already uses for other purposes. This Chapter also includes mechanisms designed to ensure that certain cross-border taxes (such as Controlled Foreign Company (CFC) taxes) are appropriately allocated to the jurisdiction where the income arises. Chapter 4

also includes a mechanism for dealing with post-filing adjustments in respect of changes relating to a local tax liability.

9. Chapter 5 sets out the steps to be taken in determining the amount of Top-up Tax of each LTCE. First, a Constituent Entity's aggregates its net income and Adjusted Covered taxes with those of other Constituent Entities located in the same jurisdiction to determine the ETR and Top-up Tax Percentage for each jurisdiction. If that jurisdiction is a Low-Tax Jurisdiction then the Substance-based Income Exclusion is applied to the total GloBE Income in the jurisdiction in order to determine the Excess Profits in that jurisdiction. The Top-up Tax Percentage is then applied to such Excess Profit in order to determine the Top-up Tax for each Low-Tax Jurisdiction. The final step is then to allocate such jurisdictional Top-up Taxes to the Constituent Entities in the Low-Tax Jurisdiction, which is where the chapter connects back with Chapter 2. Special rules apply in respect of minority owned groups. Chapter 5 further includes a de minimis exclusion for the Constituent Entities located in the same jurisdiction when their aggregated revenue and income does not exceed certain thresholds.

Reorganisations and special ownership structures

10. The consequences of a transfer of part or all of the Controlling Interests, or transfer of assets and liabilities, of a target Constituent Entity are addressed through a number of specific rules in Chapter 6. These rules include specific rules for the application of the consolidated revenue threshold to MNE Groups after a merger or demerger. They further provide for the apportionment of the target's GloBE Income and Covered Taxes and the value of deferred tax assets and deferred tax liabilities between the seller and purchaser as well as rules for calculating the tax base of the assets and liabilities of the target entity. Chapter 6 also includes special rules for JVs that bring the MNE Group's share of the JV income into scope of the GloBE Rules and special rules for Multi-parented MNE Groups.

Tax neutrality and distribution regimes

11. Chapter 7 provides specific rules that apply to certain tax neutrality and distribution regimes in order to avoid unintended outcomes under the GloBE Rules. These rules include special rules for reducing the GloBE Income of UPEs that are Tax Transparent Entities or subject to a Deductible Dividend Regime and whose owners are subject to taxation above the Minimum Rate on the UPE's GloBE Income. The rules also contain special rules for the computation of the ETR of a controlled Investment Entity and certain elections in respect of such Entities. Finally, the chapter contains special rules related to Distribution Tax Systems.

Administration and Transition rules

12. Chapter 8 sets out certain provisions in respect of the administration of the GloBE Rules. This includes the information that must be filed by the relevant Constituent Entities to demonstrate compliance with the GloBE Rules under Article 8.1. Chapter 8 also provides for the possibility of safe harbours and the issuance of administrative guidance to reduce compliance burdens, including duplicative reporting, where possible. Chapter 9 provides transition rules including rules for taking into account losses and other tax attributes that arose prior to the application of the GloBE Rules.

Defined terms

13. Chapter 10 sets out definitions of terms used in the GloBE Rules, and provides rules in Article 10.2 to define Flow-through Entities, Tax Transparent Entities, Reverse Hybrid Entities, and Hybrid Entities.

Article 10.3 sets out the rules for determining the location of an Entity for the purposes of applying the GloBE Rules.

Co-ordination and consistency requirements under common approach.

14. The GloBE Rules are intended to be implemented as part of a common approach. A jurisdiction that joins the common approach is not required to adopt the GloBE Rules but, if it chooses to do so, it agrees to implement and administer them in a way that is consistent with the outcomes provided under the GloBE Rules and this Commentary. Consistency in the implementation and administration of the GloBE Rules is intended to result in a transparent and comprehensive system of taxation that provides predictable outcomes for MNEs and avoids the risk of double or over-taxation.

Scope

15. The limitations on scope in Article 1.1 play an important role in the co-ordination mechanics for the GloBE Rules by ensuring that the application of the rules in one jurisdiction does not come into conflict with the intended outcomes under the GloBE Rules in another jurisdiction. For example, if a jurisdiction were to set a lower revenue threshold for the application of the UTPR under its domestic law this would cause the UTPR to operate as the primary rule for those MNE Groups that were above this domestic threshold but below the agreed GloBE threshold, resulting in outcomes that were contrary to the basic design of the GloBE Rules and undermining the expected outcomes for MNEs headquartered in jurisdictions that have adopted a Qualified IIR.

16. Equally, however, a co-ordinated approach to the GloBE Rules does not prevent those jurisdictions that adhere to the common approach from introducing additional measures to tax their own domestic taxpayers in respect of the foreign income of their subsidiaries and branches, provided those rules do not come into conflict with the intended outcomes under the GloBE Rules. For example, the introduction of a tax in respect of income of foreign subsidiaries that was similar to the IIR, but applied only to the foreign income of smaller locally headquartered MNE Groups (i.e. MNE Groups with annual consolidated revenues below the threshold in Article 1.1), would not be contrary to the design of the GloBE Rules or undermine the rule order that had been agreed as part of the common approach.

Currency conversion

17. The GloBE Rules set out a number of monetary thresholds that are denominated in the Euro currency. These include the consolidated revenue threshold in Article 1.1 and the De Minimis Exclusion in Article 5.5. The use of monetary thresholds can give rise to co-ordination issues where jurisdictions set these monetary thresholds in a currency other than Euros or when MNE Groups that are subject to the GloBE Rules prepare their Consolidated Financial Statements in a currency other than one referenced in the applicable domestic law.

Monetary thresholds set in local currency

18. The monetary thresholds under the GloBE Rules are set in Euros. In order to avoid the risk of differences in the application of GloBE Rules among jurisdictions it is recommended that jurisdictions implementing the GloBE Rules also use the Euro currency in their domestic legislation when setting their own thresholds. However, some jurisdictions that implement the GloBE Rules may face legal or practical impediments to using a foreign currency when setting their own monetary thresholds under domestic legislation. In these cases, a jurisdiction may provide for a threshold in its domestic currency but it should re-base the local currency threshold every year in order to minimise the difference between the local threshold and those set by other countries.

19. For those jurisdictions that introduce the GloBE Rules into their legislation using local currency thresholds other than Euros, the preferred approach would be for those jurisdictions to use a consistent methodology to re-base their local currency. Application of a consistent re-basing rule will minimise differences between the local currency thresholds used by different jurisdictions.

20. As noted further below, an MNE Group that prepares its Consolidated Financial Statements in a different currency from the one used by the domestic legislation will still need to translate the results of those financial statements into that currency to determine whether (and how) the MNE Group is subject to the GloBE Rules in that jurisdiction. This translation can only be made at the end of the MNE Group's Fiscal Year. Nevertheless, a jurisdiction can minimise the potential for uncertainty by ensuring that the methodology for re-basing currency thresholds provides MNE Groups with certainty as to what those thresholds will be at the beginning of the relevant Fiscal Year.

Co-ordination rule in the event of differences in thresholds as a result of local currency fluctuations

21. Where a jurisdiction implements GloBE Rules using monetary thresholds that are in a currency other than Euros this creates the potential for differences in the application of the GloBE Rules between that jurisdiction and other jurisdictions. For example, Country Y could use its local currency to set the monetary threshold for determining whether a fine or penalty falls within the definition of a Policy Disallowed Expense. While this threshold is originally set at the local currency equivalent of EUR 50 000, the value of Y\$ may subsequently fall against the Euro such that, when the threshold is applied, the actual monetary threshold is set at the equivalent of EUR 35 000. In this case, the drop in the exchange rate effectively results in a potential increase in the measurement of the GloBE tax base under Country Y law for certain MNE Groups because it results in fines and penalties being added-back to the calculation of GloBE Income, thereby increasing the denominator of the ETR calculation. These differences in the determination of the GloBE tax base could, in turn, have adverse implications for co-ordination and rule order. Such differences could result in Country Y applying the charging provisions under Chapter 2 in circumstances that were not contemplated by the GloBE Rules, thereby undermining the expected outcomes for another jurisdiction that has also adopted these rules.

22. Accordingly, jurisdictions that implement monetary thresholds in a currency other than Euros must create provision in their law to ensure that any such differences do not result in outcomes that are inconsistent with the common approach and the intended outcomes under the Model Rules and this Commentary. Co-ordination mechanisms consistent with the common approach may be considered as part of the Implementation Framework which will set out a process for assessing whether the domestic rules meet the qualification standards for a Qualified IIR, UTPR or Domestic Minimum Top-up Tax.

MNE Groups using a currency different to the local currency under domestic law

23. Regardless of whether the currency used to determine monetary thresholds under the GloBE Rules is set in Euros or in some other currency, it will also be necessary for an MNE Group that prepares its Consolidated Financial Statements in a currency that is different from the one set by the domestic legislation to translate the results of those financial statements into the local currency to determine whether (and how) the MNE Group is subject to the GloBE Rules in that jurisdiction. The MNE Group must convert the relevant amounts included in their Consolidated Financial Statements into local currency using an agreed methodology that provides a level playing field for MNEs and maximises consistency in outcomes across jurisdictions. For instance, if the domestic law of the UPE Jurisdiction sets the revenue threshold in Country A currency but the Consolidated Financial Statements are prepared in Country B currency then the consolidated revenue should be converted from Country B to Country A currency using the same methodology required under the GloBE Rules in other jurisdictions and applied by other MNE Groups in order to determine whether the consolidated revenue threshold has been met.

24. As part of the GloBE Implementation Framework, jurisdictions will evaluate the development of preferred methodologies for re-basing local currency thresholds and currency conversion, which meet their domestic legal requirements while providing sufficient certainty in the application of the rules and avoiding unnecessary discrepancies in the scope or operation of the GloBE Rules between different jurisdictions.

References

OECD (2017), *Model Tax Convention on Income and on Capital: Condensed Version 2017*, [1]
OECD Publishing, Paris, https://dx.doi.org/10.1787/mtc_cond-2017-en.

1 Scope

1. Chapter 1 determines which MNE Groups and Group Entities are subject to the GloBE Rules. Article 1.1 provides that the GloBE Rules will apply to the Constituent Entities of an MNE Group with consolidated revenues of at least EUR 750 million in at least two of the four prior Fiscal Years. Article 1.1 is modified by Article 6.1 which sets out further rules clarifying the application of the consolidated revenue threshold in the case of mergers and de-mergers.

2. Chapter 1 also includes a number of key definitions that are used to determine when an Entity or collection of Entities constitutes a Group and when that Group qualifies as an MNE Group. A broad definition of Entity in Chapter 10 ensures that the term captures separate legal persons as well as arrangements such as partnerships and trusts. As discussed further below in the Commentary to Article 1.2, Entities form a Group when they are under common control such that their income is (or would be) included in the same Consolidated Financial Statements. The term Constituent Entity is then used to identify the Group Entities that are subject to the GloBE Rules. In this context, an Entity with one or more PEs is divided into separate Constituent Entities. The Chapter also sets out those Entities (Excluded Entities) that are excluded from the rules. Further definitions which supplement the meaning of these terms are included in Chapter 10.

Article 1.1 - Scope of GloBE Rules

3. Article 1.1 limits the application of the GloBE Rules to MNE Groups whose annual consolidated revenues in at least two of the four preceding Fiscal Years equal or exceed EUR 750 million. These scope rules ensure that smaller Groups and purely domestic Groups remain unaffected by the GloBE Rules. The Article also clarifies that Entities that are Excluded Entities are not subject to the GloBE Rules.

Article 1.1.1

4. Article 1.1.1 has two main elements:

- a. The first element restricts the operation of the GloBE Rules to the Constituent Entities of an MNE Group. The meaning of MNE Group and Constituent Entity is discussed further in the Commentary to Article 1.2 and Article 1.3.
- b. The second element is a revenue threshold based on that used in the CbCR rules. This threshold limits the application of the rules to those MNE Groups with consolidated revenue of at least EUR 750 million in at least two of the four preceding Fiscal Years. The operation of this revenue threshold is discussed further below.

5. The consolidated revenue threshold reflects cost / benefit considerations within the context of the overall tax policy rationale of the GloBE Rules. By restricting the rules to those MNE Groups that meet the requirements of Article 1.1, the compliance and administration costs of adopting a co-ordinated global minimum tax are minimised, while preserving the overall impact and revenue benefits. Using the same monetary threshold as that used for CbCR purposes also limits the incremental compliance costs associated with the introduction of the GloBE Rules and will make it easier for tax administrations to monitor compliance with the rules based on existing information collection and exchange systems.

6. The consolidated revenue threshold applies to the revenue that is reported in the Consolidated Financial Statements of the MNE Group. The threshold uses a two-out-of-four-years test in order to reduce volatility in the application of the rules. Where the MNE Group has EUR 750 million or more of reported revenue in at least two Fiscal Years in the four-year period immediately preceding the tested Fiscal Year, the Constituent Entities that make up the MNE Group will be within the scope of the GloBE Rules. Note that consolidated revenue for the current year (i.e. the tested Fiscal Year) is not factored into the four year calculation. Excluding the current year's results from the revenue threshold test ensures that an MNE Group knows, at the beginning of the tested Fiscal Year, whether it will be subject to the GloBE Rules in that year.

7. In a limited number of cases, Consolidated Financial Statements may not be available in respect of the four Fiscal Years immediately preceding the tested Fiscal Year. This could happen because the Entities that make-up the Group may have been recently created, so that there are no financial statements for Entities in any prior year or because, prior to the tested Fiscal Year, the Entities forming the Group were standalone Entities that are not required to consolidate. Article 6.1.1(b) deals with the latter situation. Where an Entity is brought under common control with another Entity to form a Group, the consolidated revenue threshold for a prior year is met if the sum of the revenues in the financial statements of each Entity is equal or greater than EUR 750 million (see Commentary on Article 6.1.1(b)).

8. In those cases where the Entities forming the Group were recently created such that there are no financial statements for the Group in prior years, then the third year is the first year in which the GloBE Rules can apply, since, at that point, there will be two prior years to test. If the revenue threshold is met for the two prior years, the Group will be within the scope of the GloBE Rules in year three notwithstanding that the Group does not have four prior years of consolidated financial statements.

9. For instance, in Year 1, A Co and B Co are incorporated and form the AB Group. Consolidated financial statements are prepared for the AB Group. In Years 1 and 2, the AB Group has consolidated revenue of EUR 750 million. In this case, the AB Group is not within the scope of the GloBE Rules in Years 1 and 2 because Article 1.1.1 requires the AB Group to have consolidated revenues of EUR 750 million or more in at least two of the four Fiscal Years preceding the tested Fiscal Year. In Year 3, the consolidated revenue threshold has been met because in the consolidated revenue of the AB Group equals EUR 750 million two Fiscal Years preceding the tested Fiscal Year (Year 3).

Revenue threshold applies to the consolidated revenue

10. The revenue threshold takes into account the consolidated revenue as reported in the Consolidated Financial Statements of the Group. The definition of Consolidated Financial Statements in Article 10.1 includes a requirement that these statements are prepared in accordance with an Acceptable Financial Accounting Standard and a deeming provision to address those situations where the MNE Group is only a single Entity with foreign branch operations or does not otherwise prepare Consolidated Financial Statements under such a standard.

11. Where the income of an Entity is consolidated with that of an MNE Group, then the threshold in Article 1.1.1 is applied to the total amount of the Entity's revenue that is reflected in the Consolidated Financial Statements of the Group, even if a portion of the interests in that Group Entity is owned (directly or indirectly) by minority interest holders. In accounting terms, this means that the revenues taken into account in the determination of the MNE Group's total revenue under the consolidated revenue threshold should be the one reflected in the Consolidated Financial Statements and should not be reduced by the amount attributable to minority interest holders. The threshold applies based on the consolidated revenue of the MNE Group, not the aggregate of the revenues of each Group Entity. In other words, revenues from transactions with other Group Entities that are eliminated in the consolidation process are excluded from the revenue threshold test.

12. Although, as described in further detail below in the Commentary to Article 1.1.3 and Article 1.5, an Excluded Entity is not a Constituent Entity (and is, therefore, not subject to the GloBE Rules), an Excluded Entity will qualify as a Group Entity for purposes of determining the revenue threshold to the extent its income is consolidated with the rest of the Group. In this case, the revenue of that Excluded Entity must be taken into account in applying the consolidated revenue threshold. This ensures consistency with the threshold for reporting under CbCR and avoids requiring additional rules to address the treatment of revenues attributable to transactions between the Excluded Entity and the rest of the Group (including anti-avoidance rules to protect against fragmentation).

13. In cases where the revenue threshold is set in a currency other than the Euro and such amount changes on a yearly basis, the applicable revenue threshold for the Fiscal Year is the last revenue threshold in effect as of the beginning of the Fiscal Year. For example, Country A rebases its revenue threshold in local currency in December of each year, effective for Fiscal Years beginning after the 31 December. The MNE Group has a Fiscal Year that starts on 1 July 2024 and ends on 30 June 2025. The MNE Group applies the revenue threshold that is in effect on 1 July 2024.

Article 1.1.2

14. Article 1.1.2 addresses cases where a Fiscal Year of an MNE Group is a period other than 12 months. The Fiscal Year of the MNE Group is defined in Article 10.1 and is determined by reference to the annual accounting period of the UPE. The definition of Fiscal Year aligns with the test used in CbCR and ensures consistency in the application of the threshold for GloBE and CbCR purposes.

15. The rule in Article 1.1.2 applies in cases where one or more of the immediately preceding Fiscal Years use a period other than 12 months. This paragraph states that the EUR 750 million revenue threshold has to be recalculated on a proportional basis to reflect the threshold for a period other than 12 months. There are a number of ways that this recalculation can be made. For example, if the Fiscal Year of the MNE Group is comprised of 9 months, then the local tax authority could require the revenue threshold to be correspondingly reduced by a quarter to capture a proportionate amount of revenue over a 9-month period EUR 562.5 million (EUR 750 million/12 x 9). In order to reach the same outcome the group's consolidated revenue could be adjusted upward on a pro-rata basis in order to reflect the consolidated group revenue that corresponds to a 12-month Fiscal Year. For example, if the Fiscal Year of the MNE Group is comprised of 9 months and the consolidated revenue for the period is EUR 562.5 million, then the local tax authority could require the revenue to be grossed-up by the ratio of the number of months in the year to 12. Under these facts, the MNE Group's consolidated revenue for the year for purposes of applying the threshold would be EUR 750 million (= EUR 562.5 million / [9/12]).

Article 1.1.3

16. Article 1.1.3 states that Entities that meet the definition of Excluded Entities are excluded from the GloBE Rules. These Entities are excluded from the definition of Constituent Entities, thereby taking them outside the scope of the GloBE Rules (except for purposes of calculating the revenue threshold). The various types of Excluded Entities are explained further below in the Commentary to Article 1.5.

Article 1.2 - MNE Group and Group

17. Article 1.2 defines the terms "MNE Group" and "Group" for the purposes of the GloBE Rules. These terms, which are used to determine the scope of the GloBE Rules under Article 1.1, perform two key functions. Firstly, they restrict the GloBE Rules to those Groups or Entities with foreign subsidiaries or branches. Second they define the degree of common ownership and control required for two or more entities to be members of the same Group.

18. As described in the Commentary on Article 1.1, the Constituent Entities of a Group will not be subject to the GloBE Rules unless they are members of an MNE Group. Article 1.2.1 sets out the definition of an MNE Group. There are two elements to this definition:

- a. Whether two or more Entities form a *Group* is based on an accounting consolidation test. This consolidation test is determined based on the Consolidated Financial Statements prepared by the UPE. Subparagraph (d) of the definition of Consolidated Financial Statements in Article 10.1 includes a deeming provision for those UPEs that do not prepare Consolidated Financial Statements. This provision requires the use of the financial statements that would have been prepared if the UPE had been required to prepare such statements in accordance with an Authorised Financial Accounting Standard that is either an Acceptable Financial Accounting Standard or another financial accounting standard that is adjusted to prevent any Material Competitive Distortions.
- b. A Group will be an *MNE Group* if it has one or more Entities or PEs located in a jurisdiction other than the UPE jurisdiction.

19. The extended definition of Group in Article 1.2.3 ensures that the GloBE Rules also apply to a standalone Entity located in a jurisdiction that has one or more PEs located in another jurisdiction.

Article 1.2.1

20. Article 1.2.1 requires a UPE of the Group to have, directly or indirectly, at least one foreign subsidiary or PE before the Group will be considered an MNE Group. A single subsidiary or PE as defined by Article 10.1 (even one that does not earn income) located in a jurisdiction other than the one where the UPE is located is sufficient to bring a Group within the definition of an MNE Group.

Article 1.2.2

21. Article 1.2.2 defines a Group based on an accounting consolidation test. A Group is comprised of Entities (including arrangements such as partnerships or trusts that prepare separate financial accounts) that are related through ownership or control and meet either of the requirements set out in paragraph (a) or (b) of Article 1.2.2. This definition is used for purposes of defining a Constituent Entity in Article 1.3.

22. Paragraph (a) refers to a collection of Entities that are included in the Consolidated Financial Statements of the UPE. This means that the assets, liabilities, income, expenses, and cash flows (i.e. the financial results) of the Entity (including the ones of its PEs) are consolidated on a line-by-line basis in the Consolidated Financial Statements that the UPE prepares for the MNE Group. If no consolidated accounts exist, a collection of Entities would still be considered a Group if these Entities would have been so consolidated if an Entity were required to prepare such accounts with respect to the Entities it controls because the definition of term “Consolidated Financial Statements” in Article 10.1 also includes a “deemed consolidation test” in paragraph (d) which considers these Entities consolidating together and therefore, forming part of the same Group.

23. Whether an Entity is part of a Group depends on whether it meets the definition of an “Entity” under Article 10.1 and the requirements set out in paragraph (a). For example, a joint operation (as defined by IFRS (IFRS Foundation, 2022^[2])) could be a separate Entity of the Group provided that it meets the definition of an Entity (e.g., partnership) such that the portion of its assets, income, expenses, cash flows and liabilities belonging to the joint operators that are other Entities of the Group is included in the Consolidated Financial Statements on a line-by-line basis. Therefore, Entities reported under the pro rata or proportional consolidation method are Constituent Entities of the Group. In these cases, the portion of the Entity’s assets, income, expenses, cash flows and liabilities that are reflected in the Consolidated Financial Statements are taken into account for purposes of the GloBE Rules (e.g., the consolidated

revenue threshold in Article 1.1 only takes into account the amount of the revenue of the Entity that is reflected in Consolidated Financial Statements).

24. Paragraph (b) states that a Group is also comprised of Entities that are not consolidated on a line-by-line basis because they are subject to a special reporting treatment under an Acceptable Financial Accounting Standard on the grounds that the Entity is held for sale, or is excluded from consolidation based on size or materiality grounds. This type of Entity is also treated as part of the Group as long as it remains sufficiently within the control of the UPE to fall within the general consolidation requirements of the relevant Acceptable Financial Accounting Standard.

Article 1.2.3

25. In order to ensure MNE Groups that meet the consolidated revenue threshold and engage in cross-border operations through PEs rather than subsidiaries are also subject to the GloBE Rules, Article 1.2.3 provides a supplementary definition of “Group”. The definition provides that a standalone Entity, which otherwise is not a member of a Group as defined in Article 1.2.2, but has one or more PEs located in other jurisdictions, will be treated as a Group for GloBE purposes. Thus, in combination with Article 1.2.1, an Entity and its foreign PE will meet the definition of Group and MNE Group.

26. Article 1.2.3 will not apply where the Entity only has a stateless PE in accordance with paragraph (d) of the definition in Article 10.1 and Article 10.3.3(d) because such a PE is not recognised under the laws of any other jurisdiction. This narrow situation only occurs where a standalone Entity has a PE as defined by paragraph (d) of the definition of Permanent Establishment in Article 10.1.

Article 1.3 - Constituent Entity

27. The term Constituent Entity defines those Group Entities that are subject to the GloBE Rules. For example, a Group Entity must be a Constituent Entity before it can be treated as an LTCE and subject to charge under the IIR or UTPR, under Chapters 2 to 5 of the rules.

Article 1.3.1

28. The first type of Constituent Entity is defined by Article 1.3.1(a) as any Entity that is a member of a Group. Therefore, each of the Entities of the Group as determined in Article 1.2.2 will be a Constituent Entity, unless it is an Excluded Entity under Article 1.5.

29. The second type of Constituent Entity is described in paragraph (b) of Article 1.3.1. Under this paragraph, a PE, as defined in Article 10.1, of a Main Entity that is itself a Constituent Entity is treated as a separate Constituent Entity. This paragraph applies to any of the four types of PEs described in the definition of Permanent Establishment in Article 10.1.

Article 1.3.2

30. Article 1.3.2 clarifies that a PE, that is a Constituent Entity pursuant to Article 1.3.1(b) shall be treated as a separate Constituent Entity from the Main Entity and any other PEs of such Entity. The definition of PE is set out in Article 10.1, which is based on the identification of a PE as recognised for tax purposes. The need to distinguish the separate business operations undertaken in the foreign PE is essential for the jurisdictional blending calculations under Chapter 5. It ensures that the income earned through PEs in another jurisdiction and the tax imposed on that income is not blended with the tax and income of the Main Entity or another PE in a different jurisdiction. In that sense, it ensures parity in the treatment of foreign subsidiaries and PEs of the MNE Group.

Article 1.3.3

31. Article 1.3.3 provides that a Constituent Entity does not include an Entity that is an Excluded Entity. As discussed further below, Excluded Entities are therefore outside the GloBE Rules.

Article 1.4 - Ultimate Parent Entity

32. The definition of UPE is set out in Article 1.4. The UPE definition is used as part of the definition of Group and is the starting point for identifying all the Entities that comprise the MNE Group. The identification of the UPE is also relevant in other parts of the GloBE Rules. For example, the GloBE Rules give priority in the application of the IIR to the jurisdiction in which the UPE is located (the UPE Jurisdiction) and it will generally be the financial accounting standard of the UPE that is used as the basis for calculating the GloBE Income or Loss of Constituent Entities under Chapter 3.

Article 1.4.1

33. There are two types of UPEs described in paragraphs (a) and (b) of this Article. Paragraph (a) is the most common scenario. It describes the UPE of a Group as defined in Article 1.2.2, i.e. the UPE of a Group comprised of at least two Entities, while paragraph (b) describes the UPE of a Group as defined in Article 1.2.3 (i.e. a Group that is made up of a Main Entity and one or more PEs). In this case the Main Entity is treated as the UPE of the Group.

UPE of a Group as defined by Article 1.2.2

34. Paragraph (a) defines the term UPE in the case of a Group that is composed of at least two Entities in accordance with Article 1.2.2. To be a UPE of the Group, the Entity must comply with two requirements. The first condition is set out in subparagraph (i), which states that the UPE is an Entity that directly or indirectly owns a Controlling Interest in another Entity. The definition of Controlling Interest in Article 10.1 uses a consolidation test (including a deemed consolidation test) to determine whether an Entity owns a Controlling Interest in another Entity. Therefore, the requirement in subparagraph (i) is met if an Entity is required to consolidate the assets, liabilities, income, expenses and cash flows of another Entity on a line-by-line basis in accordance with an Acceptable Financial Accounting Standard or if it would have been so required if the first-mentioned Entity had prepared Consolidated Financial Statements in accordance with an Authorised Financial Accounting Standard that is either an Acceptable Financial Accounting Standard or another financial accounting standard that is adjusted to prevent any Material Competitive Distortions.

35. The second requirement is set in subparagraph (ii). It states that the Controlling Interests of the Entity should not be owned directly or indirectly by another Entity that is described in subparagraph (i). Therefore, it disqualifies an Entity from being the UPE of a Group if the Controlling Interests in that Entity are held by another Entity. Stated differently, an Entity is not considered the UPE of a Group if there is another Entity higher in the ownership chain that is required, or that would have been required, to consolidate the first-mentioned Entity on a line-by-line basis.

UPE of a Group as defined by Article 1.2.3

36. The second type of UPE is described in Article 1.4.1(b). This paragraph provides that in those cases where the Group is a single Entity with one or more foreign PEs, then the Main Entity (as defined in Article 10.1) is the UPE. As explained in the Commentary to Article 1.2.3, this extended definition of UPE is necessary to ensure that a domestic Entity that engages in cross-border operations through PEs is subject to the GloBE Rules.

Article 1.5 - Excluded Entity

37. Article 1.5 specifies those Entities that are Excluded Entities and therefore not subject to the GloBE Rules. Qualification as an Excluded Entity has three practical effects under the GloBE Rules:

- a. First, the IIR and UTPR do not apply to Excluded Entities. For example, only Constituent Entities are required to apply the IIR in accordance with Article 2.1. Therefore, an Excluded Entity that is the UPE of the MNE Group is not required to apply the IIR, and the rule must be applied by the next Entity in the ownership chain (that is not itself an Excluded Entity).
- b. Second, the GloBE attributes of Excluded Entities (including their profits, losses, taxes accrued, tangible assets, and payroll expenses) are removed from the various computations under the GloBE Rules, except for the application of the revenue threshold as described above.
- c. Finally, Excluded Entities do not have any administrative obligations under the GloBE Rules, such as the filing of a GloBE Information Return, and information related to their income, taxes, assets, etc. is not reported in the GloBE Information Return (other than the information relating to Excluded Entities required under Article 8.1.4(b) and any other information as agreed in the GloBE Implementation Framework).

38. Article 1.5 is divided into three provisions. Article 1.5.1 lists the type of Entities that are Excluded Entities. Article 1.5.2 extends the exclusion to Entities owned by such Excluded Entities provided that certain tests are met. Lastly, Article 1.5.3 provides an option to the Filing Constituent Entity to elect not to treat an Entity as an Excluded Entity under Article 1.5.2.

39. In some cases, an MNE Group could be composed exclusively of Excluded Entities. For example, an Investment Fund may be required to consolidate the assets, liabilities, income and expenses of separate investment vehicles that it controls. However, if those investment vehicles all meet the conditions of Article 1.5.2, the MNE Group would be excluded from the GloBE Rules as a whole because the Group would not include any Constituent Entities that are required to undertake an ETR calculation or apply the charging provisions of Chapter 2 or comply with the administrative provisions of the rules.

Article 1.5.1

40. Article 1.5.1 lists the types of Entities that are Excluded Entities. Generally these Entities would not be consolidated on a line-by-line basis with a Group of operating Entities and therefore, would not have been considered as Constituent Entities of such Group under the tests set out in Article 1.3. However, for completeness, consistency and to improve certainty of outcomes, Article 1.5.1 explicitly provides a list of Excluded Entities.

41. The Entities referred in paragraphs (a) to (d) of Article 1.5.1 are Governmental Entities, International Organisations, Non-profit Organisations, and Pension Funds. Each of these are defined in Article 10.1 and discussed more fully in the Commentary to that Article.

42. The Excluded Entities identified in para (e) and (f) are investment funds and real estate investment vehicles that are UPE of MNE group. These entities are excluded from the GloBE Rules in order to protect their status as tax neutral investment vehicles. If an Investment Fund or Real Estate Investment Vehicle is not the UPE of the MNE Group it can still be treated as a Constituent Entity of the MNE Group provided it otherwise meets the consolidation requirements of Article 1.2 and Article 1.3. However such Investment Funds and Real Estate Investment Vehicles are considered as Investment Entities and subject to special rules for calculation of ETR in Article 7.4 through to 7.6.

Article 1.5.2

43. Article 1.5.2 is an extension of the definition of an Excluded Entity in Article 1.5.1 that covers Entities owned by an Excluded Entity. Article 1.5.2 recognises that Excluded Entities may be required, for regulatory or commercial reasons, to hold assets or carry out specific functions through separate controlled entities. For example, commercial or regulatory requirements may prevent an Investment Fund referred in Article 1.5.1(e) from investing directly in an asset and may require the investment to be made through a separate vehicle to limit the Investment Fund's liability. The rule in Article 1.5.2 addresses these types of situations and may permit such a holding vehicle to qualify as an Excluded Entity. Article 1.5.2 is divided into two paragraphs:

- a. Paragraph (a) addresses the situation where an Excluded Entity under Article 1.5.1 sets up an Entity to hold its assets or invest its funds, or to carry out activities that are ancillary to the Excluded Entity's activities.
- b. Paragraph (b) addresses the situation where an Excluded Entity sets up an Entity whose financial accounting net income would otherwise be excluded from the GloBE computations because it is composed of Excluded Dividends or Excluded Equity Gain or Loss.

44. Article 1.5.2 does not apply if the Entity referred in paragraphs (a) or (b) is held by a Pension Services Entity (as defined in Article 10.1). As described further in the Commentary to Article 10.1, Pension Services Entities are special purpose vehicles that may perform similar functions to the Entities described in Article 1.5.2. Allowing a Pension Services Entity to establish a further separate controlled entity that qualified for Excluded Entity status would dilute the intended effect of the rules in Article 1.5.2, which are intended to be limited to those controlled entities that carry out functions for the Excluded Entity (such as the Governmental Entity, International or Non-profit Organisations or Pension Fund itself).

45. Article 1.5.2 applies where an Entity that is a member of a Group is held by an Excluded Entity as defined in Article 1.5.1 that is not a member of that Group. An Entity that is a member of a Group that is held by an Investment Fund or a Real Estate Investment Vehicle can still meet the requirements under Article 1.5.2 notwithstanding that that the Investment Fund or Real Estate Investment Vehicle is not the UPE of that Group. For example, an Investment Fund wholly-owns an Entity that is the UPE of a Group and that meets the requirements under Article 1.5.2. In this case, the UPE is an Excluded Entity under Article 1.5.2 notwithstanding that the Investment Fund is not part of the Group because it is not consolidated on a line-by-line basis with such Group.

Paragraph (a)

46. In order to qualify as an Excluded Entity under Article 1.5.2(a) the Entity must meet two tests: an ownership test and an activities test.

Ownership test

47. The ownership test is set out at the beginning of paragraph (a). Under this test, one or more Excluded Entities defined in Article 1.5.1 must own at least 95% of the value of the Entity. The 95% threshold allows for situations in which there is a small minority interest holder, such as where a fund manager holds a small percentage of an Investment Fund or where domestic law requires at least two shareholders to incorporate a corporation or where an Excluded Entity invests through a partnership and is required to have another Entity acting as the general partner for domestic law purposes.

48. Paragraph (a) also applies if the Excluded Entity under Article 1.5.1 owns at least 95% of the value of the Entity through a chain of Excluded Entities. For instance, A Co is an Excluded Entity under Article 1.5.1. A Co wholly-owns B Co (another Excluded Entity), which in turn owns 95% of the value of C Co. In this case, C Co meets the ownership test under paragraph (a) because 95% of its value is indirectly

owned by A Co. In contrast, if A Co owned 95% of Ownership Interests of B Co, then the ownership test is not met with respect to C Co because the value owned by A Co has been diluted to 90% (95% x 95%).

49. The phrase “value of the Entity” refers to the total value of the Ownership Interests issued by the Entity. In the case of shares, it refers to the value of the issued and outstanding shares that are held by shareholders. The value of the Entity is different from a direct measurement of the amount of Ownership Interests held by the Excluded Entity which refers to the underlying rights to profits, capital or reserves of such Entity. The difference between a measurement based on “value of the Entity” and a measurement based on “Ownership Interest” is that the former looks to the aggregate value of the Ownership Interests held by the Excluded Entity as a percentage of the overall value of the Ownership Interests issued by the Entity while the second one compares one or more of the specific rights (i.e., profits, capital or reserves) that are carried by the Ownership Interest.

50. The ownership test referred in this paragraph is only met where 95% or more of the value of the equity interests of the Entity are beneficially owned (either directly or indirectly) by Excluded Entities. The assessment of the value should be made as of the date of the most recent change in the Excluded Entity’s relative Ownership Interests in the Entity and should take into account the value of all the Ownership Interests held by the Excluded Entity. For instance, a newly formed Entity issues 200 ordinary shares worth EUR 1 each and 100 preferred shares worth EUR 2 each. An Excluded Entity shareholder receives all the ordinary shares and 90 of the preferred shares. In this situation, the value of the Entity would be 400 and the Excluded Entity shareholder owns 95% (380/400) of the value of the Entity for purposes of Article 1.5.2.

51. The value of an Excluded Entity’s interest in an Entity should be measured as of the date of the most recent change in the Excluded Entity’s relative Ownership Interests in the Entity. For example, if the Entity issues new shares to a minority shareholder / employee as part of a compensation package, the Excluded Entities should determine whether they still hold 95% of the value of the Ownership Interests of the Entity immediately after such share issuance. However unrealised movements in the comparative value between different classes of shares should not affect the application of the test under Article 1.5.2 until there is a change in the Excluded Entity’s relative Ownership Interests in the Entity. For example, if the value of the Ownership Interests of the Entity in the example above fell to 300 such that the ordinary shares are now worth only 100, the Excluded Entity should still be treated as holding 95% of the value of the Entity despite the fact that the total market value of its shares is 93% (280/300) of the Entity as a whole.

Activities test

52. The activities test is divided into subparagraphs (i) and (ii) of Article 1.5.2 (a).

53. Subparagraph (i) requires that the Entity operates “exclusively or almost exclusively to hold assets or invest funds.” The words “exclusively or almost exclusively” denote a facts and circumstances test that requires all or almost all of the Entity’s activities to be related to holding assets or investing funds. This language further means that in order to be an Excluded Entity under paragraph (a), the Entity must not actively carry out activities other than holding assets or investing funds. For example, subparagraph (i) could apply to a sovereign wealth fund owned by a government (in case it does not already meet the definition of a Governmental Entity under Article 10.1) that is holding assets and investing funds for the benefit of the government, but it would not extend to an airline company owned by the government, because an airline’s activities go beyond holding assets and investing funds. Subparagraph (i) also requires that the assets are held or funds invested “for the benefit of the Excluded Entity”. This condition has to be read in conjunction with the other conditions of this Article. For example, this condition is still met even if the fund manager benefits from the investments made by such Entity in proportion to its ownership percentage.

54. Alternatively, the activities test is met under subparagraph (ii) if the Entity only carries out activities that are ancillary to the activities carried out by an Excluded Entity. This alternative activities test was included because in some situations the activities that would otherwise be performed by the Excluded

Entity referred in Article 1.5.1 are outsourced to a separate legal Entity that is wholly-owned by the Excluded Entity (including those that are 95% owned). For example, if an Excluded Entity sets up an information technology service company that provides services exclusively to the Excluded Entity, then such company would meet the requirement under subparagraph (ii).

Paragraph (b)

55. Paragraph (b) covers the case where an Excluded Entity referred to in Article 1.5.1 (other than a Pension Services Entity) owns at least 85% of the value of another Entity whose Financial Accounting Net Income or Loss would otherwise be excluded from the GloBE Income or Loss because it is primarily composed of Excluded Dividends or Excluded Equity Gains or Losses that are excluded from GloBE Income in accordance with Article 3.2.1(b) or (c). These type of holding vehicles would not be expected to be subject to a Top-up Tax under the GloBE Rules because all of their income is excluded from the GloBE Income. The practical effect of this provision is that it prevents these Entities from applying the charging provisions in Chapter 2. The ownership percentage in paragraph (b) is lower than in paragraph (a) in order to provide greater flexibility, in particular, in the context of vehicles held by Investments Funds where third parties may hold a greater stake or where the interests in the holding vehicle are issued to management or other employees of the operating company. The meaning of the phrase “value of the Entity” is explained in the Commentary on Paragraph (a).

56. The phrase “substantially all of its income” (i.e. all or almost all of its income) was included to avoid a situation where the Entity fails to qualify under paragraph (b) solely because it receives a small amount of income other than dividend and other equity returns on controlled companies. For example, the interest received from a bank on money that passes through the Entity’s bank account should not prevent the Entity from qualifying as an Excluded Entity under paragraph (b) provided that such interest income represents an insignificant amount of its overall income.

Article 1.5.3

57. Article 1.5.3 provides an election to ignore Article 1.5.2 with respect to an Entity that qualifies as an Excluded Entity under that Article. The election is a Five-Year Election (as defined by Article 10.1). When the election is made, the GloBE Rules will apply to the Entity described in Article 1.5.2 in the same manner as they apply to any other Constituent Entity of the MNE Group. For example, a Filing Constituent Entity may elect to treat an Entity as a Constituent Entity rather than an Excluded Entity under Article 1.5.2 in order to apply the IIR and not the UTPR with respect to the Top-up Tax of the LTCE. Take, for example, an MNE Group with a UPE that is an Investment Fund which is an Excluded Entity, but which, consolidates on a line-by-line basis with its subsidiaries under the Acceptable Financial Accounting Standard used to prepare its Consolidated Financial Statements. Such MNE Group may make this election such that the Entity can apply the IIR to its subsidiaries instead of subjecting all of its Constituent Entities to the UTPR.

References

IFRS Foundation (2022), *International Financial Reporting Standards*, <https://www.ifrs.org/>. [2]

2 Charging Provisions

1. The second chapter of the GloBE Rules sets out the general charging provisions. The charging provisions are made up of two interlocking rules, the IIR and the UTPR. The IIR is applied by certain Parent Entity in the MNE Group using an ordering rule that generally gives priority in the application of the rule to the entities closest to the top in the chain of ownership (the “top-down” approach). The IIR imposes a Top-up Tax with respect to LTCEs that are subject to an ETR below the Minimum Rate. The UTPR serves as a backstop to the IIR. It denies deductions (or requires an equivalent adjustment) to certain Constituent Entities to the extent that an LTCE is not subject to tax under an IIR.
2. Taken together, the IIR and UTPR provide a systematic solution to ensure all in scope MNE Groups pay a minimum level of tax on their profits in excess of a routine return in the jurisdictions in which they operate. However, concerns about the intended application of these rules can arise where a Parent Entity jurisdiction, which would otherwise apply the IIR in accordance with the provisions of Article 2, has entered into bilateral Tax Treaties in which it has adopted the exemption method (instead of a credit method) to eliminate double taxation of income arising in the other jurisdiction. In this case, a switch-over rule in a Tax Treaty could facilitate the application of the IIR by the jurisdiction of residence of the Parent Entity to tax the income of the PE in those cases where the IIR applies as a matter of domestic law. The switch-over rule could safeguard the application of the IIR by the residence state with respect to a PE. The rule would, by virtue of its domestic law trigger, only apply when and to the extent that a resident of a Contracting State was required to apply the IIR with respect to a PE in the other Contracting State.

Overview of the IIR

3. The IIR is comprised of three Articles:
 - a. Article 2.1 identifies the Entities in the MNE Group that are required to apply the rule. The IIR is applied by a Parent Entity, which under the definition in Article 10.1, can be a UPE that is not an Excluded Entity, or an Intermediate Parent Entity, or a POPE.
 - b. Article 2.2 provides a formula for attributing the Top-up Tax to the relevant Parent Entity based on its interest in the LTCE’s income.
 - c. Article 2.3 provides a mechanism for offsetting the Top-up Tax allocated to a Parent Entity by the amount of Top-up Tax allocated to another Parent Entity that is also required to apply the IIR to the same LTCE in order to avoid double taxation. These rules are intended to coordinate the application of the IIR in certain tiered or split-ownership structures to ensure that any portion of the profits of the MNE Group are subject to the IIR in only one jurisdiction.

An overview of each of these Articles is set out below.

4. Article 2.1.1 provides the main rule for the application of the IIR in the UPE Jurisdiction. It is generally the UPE Jurisdiction which will impose the Top-up Tax in respect of LTCEs within the MNE Group if that jurisdiction has adopted the IIR. If the UPE is in a jurisdiction where a Qualified IIR is in effect for the Fiscal Year and none of the LTCEs of the MNE Group are held by a POPE required to apply a Qualified IIR, then the IIR will only be applied by the UPE in the UPE Jurisdiction. Under this corporate structure, if the UPE is located in a jurisdiction where it is not required to apply a Qualified IIR for the Fiscal Year, then

under the top-down approach the next Intermediate Parent Entity down the ownership chain is required to apply the IIR to its Allocable Share of the Top-up Tax for an LTCE in which it holds a direct or indirect Ownership Interest in accordance with Article 2.1.2.

5. Articles 2.1.2 and 2.1.3 address the application of the IIR by an Intermediate Parent Entity. Article 2.1.2 uses the same language and mechanics included in Article 2.1.1. It takes into account the Intermediate Parent Entity's Allocable Share of the Top-up Tax of the LTCE based on its direct or indirect Ownership Interest notwithstanding the other higher-tier Parent Entities' Allocable Shares of the Top-up Tax of the same LTCE.

6. It is possible that more than one Intermediate Parent Entity in the same MNE Group could be required to apply the IIR with respect to its Allocable Share of Top-up Tax from an LTCE. In these cases, each Intermediate Parent Entity is required to apply the IIR. However, where two or more Intermediate Parent Entities are part of the same ownership chain and are required to apply the IIR with respect of the same LTCE, double taxation is avoided by applying the top-down approach and turning off the IIR of the lower tier Entity, or by reducing the Top-up Tax of the upper-tier Entity by the amount of the Top-up Tax that has been brought into charge by the lower-tier Entity. The circumstances under which each of these methods is used is further discussed below.

7. Articles 2.1.4 to 2.1.5 apply to so-called "split-ownership structures", where some of the LTCEs have a significant (i.e. more than 20%) minority interest holder outside the MNE Group. In this case, the GloBE Rules depart from the top-down approach and instead require a POPE to apply the IIR notwithstanding that it is in a lower-tier of the ownership chain.

8. The rules applicable to split-ownership structures are designed to address the potential for leakage under the GloBE Rules without imposing a disproportionate tax burden on the MNE Group in respect of the low-taxed income that is beneficially owned by the minority. For example, if the UPE owns 60% of a Parent Entity (i.e. the minority-interest owners own 40%) and that Parent Entity owns 100% of an LTCE, the UPE would pay a 60% share of the Top-up Tax under Article 2.1.1. Absent additional rules, this would leave a significant part of the income of the LTCE unaffected by the IIR, giving rise to tax leakage and distortions (e.g., an MNE Group can spin off a minority interest in its subsidiaries to its existing shareholders to reduce the UPE's Top-up Tax liability). Accordingly, rather than requiring the UPE to pay Top-up Tax with respect to the share of the LTCE's income beneficially owned by minority-interest owners, the IIR requires the Parent Entity (a POPE) to also apply the IIR with respect to its share of the Top-up Tax thereby ensuring that the tax burden arising under the GloBE Rules is borne by the minority-interest owners in the right proportion.

9. The split-ownership rules operate as an exception to the top-down approach, in that the POPE has priority to apply the IIR irrespective of whether the UPE is also applying a Qualified IIR. This means that the Qualified IIR can apply more than once with respect to the same LTCE. To avoid double taxation, the UPE (or next tier Intermediate Parent Entity, if the UPE is not applying the IIR) will then reduce its Top-up Tax liability with respect to any portion of the Top-up Tax that would be charged to the POPE under a Qualified IIR in accordance with Article 2.3. More detailed Commentary on the operation of each of these rules is contained below.

10. Article 2.1.6 requires the IIR to be applied with respect to LTCEs that are not located in the implementing jurisdiction, i.e. the jurisdiction of the Parent Entity required to apply the IIR. This means that the IIR only applies with respect to Constituent Entities located in a different jurisdiction and Stateless Constituent Entities, when the MNE Group is otherwise within the scope of the GloBE Rules. Jurisdictions that introduce the GloBE Rules, may however extend the operation of the global minimum tax to the entities located in the parent jurisdiction. More detailed Commentary on the application of the IIR to domestic LTCEs is contained below.

Article 2.1 - Application of the IIR

Article 2.1.1

11. Article 2.1.1 provides the main rule for application of the IIR. It applies when a UPE, that is a Constituent Entity, “owns (directly or indirectly) an Ownership Interest in a Low-Taxed Constituent Entity at any time during the Fiscal Year”. The amount of the Ownership Interests held by the UPE in the LTCE is not directly relevant in the determination of whether this Article applies because a pre-requisite of this rule is that the low-taxed Entity is a Constituent Entity (or treated as such in the case of JVs) and a member of the MNE Group.

12. Article 2.1.1 also contains the main charging provision of the IIR. It requires the UPE to pay a tax in an amount equal to its Allocable Share of the Top-up Tax of that LTCE for the Fiscal Year. The determination of a Parent Entity’s “Allocable Share” is discussed in the Commentary to Article 2.2.

13. The IIR applies if the UPE holds Ownership Interests of the LTCE “at any time during the Fiscal Year”. This means that the UPE is required to apply the IIR with respect to a Constituent Entity that was disposed or acquired during the Fiscal Year. The holding period of the interests during the Fiscal Year is not relevant for purposes of applying Article 2.1.1 because this is already reflected in the computation of the Top-up Tax under Chapter 5. The calculation of the Top-up Tax takes into account the amount of income reported in the Consolidated Financial Statements which takes into account the holding period in which the UPE owns an LTCE for the Fiscal Year. The special rules under Article 6.2.1 provide greater detail on how the GloBE Rules operate under these circumstances, including how the IIR and top-down approach apply.

Article 2.1.2

14. Article 2.1.2 provides the rules for application of the IIR by an Intermediate Parent Entity. An Intermediate Parent Entity is defined in Article 10.1 as a Constituent Entity (other than a UPE, POPE, PE or Investment Entity) that owns (directly or indirectly) an Ownership Interest in another Constituent Entity in the same MNE Group. Investment Entities (i.e., an Investment Fund or a Real Estate Investment Vehicle and certain subsidiaries of such entities as set out in the Article 10 definition) are excluded from the definition of Intermediate Parent Entity and Parent Entity in order to preserve the tax neutrality of the Investment Entity vis-à-vis any minority-interest holders. The treatment of Investment Entities is discussed in more detail in the Commentary to Article 7.4 to Article 7.6. To avoid difficult factual determinations and disputes as to whether the Ownership Interests in LTCEs are held by the PE or the Main Entity, PEs are not treated as Parent Entities under the GloBE Rules. In this context, Ownership Interests in an LTCE that are held through a PE are treated, instead, as held by the Main Entity.

15. Article 2.1.2 requires an Intermediate Parent Entity that directly or indirectly owns Ownership Interests in an LTCE at any time during the Fiscal Year to apply the IIR and pay the Top-up Tax based on its “Allocable Share of the Top-up Tax of that Low-Taxed Constituent Entity”. The rules apply in the same way as for a UPE in Article 2.1.1, except that they only apply with respect to the relevant sub-set of Constituent Entities whose Ownership Interests are directly or indirectly owned by the Intermediate Parent Entity. Where the language in Article 2.1.2 mirrors Article 2.1.1, the corresponding part of the Commentary on Article 2.1.1 is also applicable to Article 2.1.2. The Intermediate Parent Entity’s Allocable Share of the Top-up Tax is not limited by the UPE’s allocable share. For example, a UPE (that is located in a jurisdiction without a Qualified IIR) owns 90% of the Ownership Interests of an Intermediate Parent Entity that in turn owns 100% of the Ownership Interests of an LTCE. The Allocable Share of these two Parent Entities in the LTCE is based on the Ownership Interests that they directly or indirectly hold in the LTCE. Therefore, the Intermediate Parent Entity’s Allocable Share of the LTCE’s Top-up Tax is 100%, while the UPE’s Allocable Share of the same LTCE would be 90%.

16. The amount of Ownership Interests held by the Intermediate Parent Entity in the LTCE is not relevant to whether Article 2.1.2 applies. Accordingly, the Intermediate Parent Entity is not required to have a Controlling Interest in the LTCE to apply the IIR as long as the LTCE is a member of the same MNE Group. For example, an Intermediate Parent Entity may hold a 10% Ownership Interest in an LTCE and still be required to apply the IIR in accordance with Article 2.1.2. The amount of Top-up Tax that the Intermediate Parent Entity is required to pay, however, is limited to the Intermediate Parent Entity's Allocable Share in respect of its Ownership Interest (i.e., equity interest) as set out in Article 2.2.1.

Article 2.1.3

17. The “top-down approach” is embodied in Article 2.1.3, which generally gives priority to apply the IIR to the Parent Entities at the top of the ownership chain. The mechanics of this provision limit the application of Article 2.1.2 to prevent instances of double taxation that would be caused by multiple Parent Entities applying the IIR with respect to the same Ownership Interest in the LTCE.

18. Article 2.1.3 (a) deactivates Article 2.1.2 and prevents the application of the IIR at the Intermediate Parent Entity level when the UPE is required to apply a Qualified IIR for the Fiscal Year. The phrase “required to apply a Qualified IIR” ensures that the exclusion in Article 2.1.3(a) only operates where the domestic tax legislation of the UPE jurisdiction requires the UPE to apply a Qualified IIR. Article 2.1.3(a) would not apply, for example, where the UPE jurisdiction has introduced a Qualified IIR but it is still not in force or the UPE is an Excluded Entity that is outside the scope of such rules.

19. Article 2.1.3(b) regulates the “top-down approach” where two or more Intermediate Parent Entities are required to apply the IIR to the same LTCE. It prevents the application of the IIR at the level of an Intermediate Parent Entity when the Controlling Interests of such Entity are held directly or indirectly by another Intermediate Parent Entity which is required to apply a Qualified IIR.

20. Article 2.1.3(b) does not apply and the IIR is not deactivated if one Intermediate Parent Entity does not have a Controlling Interest in the other Intermediate Parent Entity. Accordingly, the IIR can be applied by more than one Intermediate Parent Entity in the same MNE Group.¹

Article 2.1.4

21. Article 2.1.4 provides the rules for the application of the IIR by a POPE. The rules in Article 2.1.4 require a POPE that directly or indirectly owns an Ownership Interest in an LTCE at any time during the Fiscal Year to apply the IIR and pay Top-up Tax based on its Allocable Share of the Top-up Tax. The reference in Article 2.1.4 “notwithstanding Article 2.1.1 and 2.1.3” means that the rules apply regardless of whether the UPE or an Intermediate Parent Entity is also required to apply a Qualified IIR. Where the language in Article 2.1.4 mirrors Article 2.1.1, the corresponding part of the Commentary on Article 2.1.1 is also applicable to Article 2.1.4.

Article 2.1.5

22. Article 2.1.5 provides a priority rule for scenarios in which two or more POPEs are situated in the same ownership chain and are required to apply the IIR with respect to the same LTCE. This Article prevents the application of the IIR with respect to a POPE if it is entirely held (directly or indirectly) by another POPE that is also required to apply the IIR, which is consistent with the top-down approach.

23. This paragraph only applies where the POPE is wholly owned by another POPE. This differs from the language of paragraph (b) of Article 2.1.3 (the priority rule for Intermediate Parent Entities), which requires a direct or indirect Controlling Interest by a higher tier Intermediate Parent Entity to deactivate the rule. This nuance is deliberate and addresses structures with minority interests at each level in a partially owned sub-group. Utilising a control test in this context would apply the IIR at higher levels in the partially

owned chain, and leave the Top-up Tax attributable to lower-tier minority interests outside the scope of the rule. Accordingly, to prevent distortions and ensure that the appropriate amount of Top-up Tax is taken into account, a POPE must apply the IIR unless it is wholly owned (directly or indirectly) by another POPE that is required to apply a Qualified IIR for the Fiscal Year.²

Article 2.1.6

24. Article 2.1.6 requires the application of the IIR by the Parent Entity to Low-Taxed Constituent Entities that are located outside the implementing jurisdiction. It is recognised, however, that some IF members may wish to extend the application of the IIR domestically in order to avoid discriminating between domestic and foreign Constituent Entities that are members of the same MNE Group. In these cases an implementing jurisdiction may introduce further rules that require a Parent Entity to bring into account its share of Top-up Tax attributable to its Ownership Interest in domestic Low-Taxed Constituent Entities together with any Top-up Tax allocated to that Parent Entity itself. Under this approach a Parent Entity located in a Low-taxed Jurisdiction would apply an IIR to its allocable share of Top-up Tax of any domestic Low-Tax Constituent Entities and also apply the IIR in respect of any Top-Up Tax that would otherwise be allocated to the Parent Entity under Article 5.2.4.

25. An IIR that is applied to a Parent Entity's Ownership Interest in its domestic Low Tax Constituent Entities shall be treated as a Qualified IIR, provided it meets the other requirements set out in the GloBE Rules and the Commentary. The application of such a domestic IIR will remain subject to the operation of the agreed rule order in Chapter 2, including the top-down approach and the split-ownership rules and any Top-up Tax collected under a domestic IIR should be recognised as an IIR tax by other jurisdictions in accordance with the ordinary rules in Chapter 2. Similarly, where a jurisdiction also requires the Parent Entity to apply a domestic IIR to itself, any Top-up Tax payable as a result of the application of that rule is treated as having been brought into charge under an IIR notwithstanding that the tax imposed relates to the Top-up Tax allocated to the Parent Entity itself. Such IIR will be treated as a Qualified IIR under the GloBE Rules provided the circumstances in which such tax is imposed, and the amount of tax brought into charge, is the same as the tax that would have been imposed had the Parent Entity held 100% of the Ownership Interests in itself. The application of a domestic IIR in this situation should be distinguished from a domestic minimum top-up tax that could be applied to all the Constituent Entities located in the same jurisdiction and regardless of whether that Constituent Entity was a Parent Entity required to apply an IIR.

26. For example, assume Hold Co is the UPE of an MNE Group located in jurisdiction A. It owns 100% of the Ownership Interests of B Co 1 which is located in Country B. B Co 1 is also a Parent Entity because it owns 100% of the Ownership Interests of B Sub 1 (also located in Country B). Jurisdictions A and B have introduced the GloBE Rules but, in order to address potential discrimination concerns, Jurisdiction B requires a Parent Entity located in that jurisdiction to apply an IIR to its allocable share of Top-up Tax of any domestic Low-Tax Constituent Entities as well as to any Top-Up Tax that would otherwise be allocated to that Parent Entity under Article 5.2.4. Country B is considered a Low-Tax Jurisdiction for the Fiscal Year. In this scenario, only Hold Co can apply the IIR and collect the Top-up Tax of the Entities located in jurisdiction B in accordance with Articles 2.1.1 and 2.1.3(a). In a case where jurisdiction A has not adopted the GloBE Rules, B Co 1 would then apply the IIR with respect to its allocable share of Top-up Tax of B Sub 1 and B Co 1 should also be treated as applying an IIR in respect of any Top-up Tax that would otherwise be allocated to itself under Article 5.2.4.

Article 2.2 - Allocation of Top-up Tax under the IIR

27. Entities subject to the IIR pay tax in an amount equal to their "Allocable Share" of Top-up Tax. Article 2.2 contains the rules for the attribution of Top-up Tax under this rule. Article 2.2.1 first defines the

Allocable Share of Top-up Tax for a Parent Entity as the amount of Top-up Tax calculated under Chapter 5 multiplied by the Inclusion Ratio. Article 2.2.2 then provides the operative definitions necessary to perform these computations, reducing by the amount of GloBE Income attributable to other owners under the rules of Article 2.2.3 and taking into account special rules under Article 2.2.4 for Flow-through Entities where applicable.

Article 2.2.1

28. Article 2.2.1 provides the formula for the allocation of Top-up Tax. The Article allocates to the Parent Entity applying the IIR (as determined by Article 2.1) its Allocable Share of Top-up Tax liability. The Allocable Share is the amount of Top-up Tax owed in respect of an LTCE, determined by reference to the Parent Entity's Ownership Interest in the income of the LTCE. This is achieved by multiplying the Top-up Tax of the LTCE by the Parent Entity's Inclusion Ratio.

Article 2.2.2

29. Article 2.2.2 defines the Parent Entity's Inclusion Ratio for the purposes of applying the IIR. The Inclusion Ratio is, in essence, the ratio of the Parent Entity's share of an LTCE's GloBE Income to its total GloBE Income for the Fiscal Year. Where a subsidiary is wholly owned, the Inclusion Ratio will always be 1 and no additional computations are required. However, Article 2.2.2 achieves that result by subtracting the amount of GloBE Income allocable to Ownership Interests held by other owners from the total GloBE Income and dividing the difference by the total GloBE Income of the Entity. The determination of the amount of GloBE Income allocable to Ownership Interests held by other owners is determined under Article 2.2.3.

Article 2.2.3

30. Article 2.2.3 provides the mechanism by which GloBE Income attributable to other owners as set out in Article 2.2.2(a) is computed. The starting point to determine such amount is the GloBE Income or Loss computation for a Constituent Entity in Chapter 3, which starts with the Entity's Financial Accounting Net Income or Loss and makes adjustments from there. The Constituent Entity's income is determined on a separate entity basis and transactions between Group Entities are generally respected; the GloBE Income computation generally does not take into account elimination adjustments that would be made in the financial statement consolidation process. Article 3.2.8 allows the MNE Group to apply its consolidated accounting elimination adjustments, but only in respect of transactions between Group Entities in the same jurisdiction. Thus, in most cases, it is unlikely that an LTCE's GloBE Income will exactly equal the accounting income that is ultimately reflected in the Consolidated Financial Statements. In some cases, the Financial Accounting Net Income or Loss of an LTCE may be zero after consolidation adjustments. However, it is the GloBE Income, not the Financial Accounting Net Income, that must be allocated to the Parent Entity applying the IIR.

31. Consolidated Financial Statements generally reflect all of the assets, liabilities, income, expenses and cash flows of controlled subsidiaries. However, the owners of the UPE do not have an interest in 100% of those items if the subsidiary is partially owned by third parties. Thus, the UPE must evaluate the extent to which the assets, liabilities, income, expenses and cash flows of its subsidiaries belong to minority interest holders in order to properly report the portion that belongs to its owners in the Consolidated Financial Statements. The consolidated profit and loss statement will include a reduction to the total income for the portion that belongs to minority owners in arriving at the UPE's consolidated net income. Similarly, the consolidated balance sheet includes a line item reflecting the cumulative equity of the minority owners in the total assets of the consolidated group. Without these adjustments, the Consolidated Financial Statements would overstate the portion of the income of the consolidated group that belongs to or inures to the benefit of the owners of the UPE.

32. The GloBE Rules leverage the principles that the UPE applies, or would need to apply, in its Consolidated Financial Statements to determine the share of income of the Financial Accounting Net Income or Loss that belongs to other owners of an LTCE that it does not wholly own. When the IIR is applied by an Intermediate Parent Entity or a POPE, the rules further require that Parent Entity to apply the principles that the UPE applies to minority owners to their separate ownership interests in LTCEs. To this end, Article 2.2.3 requires a hypothetical allocation (in accordance with those principles) of an amount of financial accounting income that is equal to the LTCE's GloBE Income based on the assumptions in paragraphs (a) to (d).

33. The first assumption, contained in paragraph (a), is that the Parent Entity performing this hypothetical allocation, prepared Consolidated Financial Statements using the same accounting standard used in the UPE's Consolidated Financial Statements (the hypothetical Consolidated Financial Statements). This assumption is necessary where the Parent Entity is not the UPE. Although the UPE actually prepared Consolidated Financial Statements, those statements are the hypothetical Consolidated Financial Statements for purposes of Article 2.2.3. The assumption sets a uniform accounting standard to properly allocate the LTCE's GloBE Income, and in turn Top-up Tax, among Parent Entities applying the IIR. Because all Parent Entities will be applying the same accounting standard to determine their Inclusion Ratio, there will be no leakage (or duplication) of Top-up Tax liability and there will be a proper coordination under Article 2.3 between the application of the IIR by a Parent Entity and a POPE in respect of the same LTCE.

34. The second assumption, contained in paragraph (b), is that the Parent Entity owned a Controlling Interest in the LTCE such that the income and expenses of the LTCE were consolidated on a line-by-line basis with those of the Parent Entity in the hypothetical Consolidated Financial Statements (i.e. the amount of each item of income and expense of the LTCE accrued under the accounting standard for the Fiscal Year is included in the consolidated amount of each item of income and expense reflected in the hypothetical Consolidated Financial Statement). The LTCE is a Constituent Entity because the UPE owns a Controlling Interest in it. However, the UPE's Controlling Interest may not be held through the Parent Entity required to apply the IIR. That Parent Entity may only hold a minority interest in the LTCE, in which case the Parent Entity would not be required to consolidate its accounts on a line-by-line basis with the LTCE. The Parent Entity might otherwise, for example, include only the net profit or loss of the LTCE under the equity method in the Consolidated Financial Statements if it only took into account its Ownership Interests for this purpose. The assumption in paragraph (b) is intended to clarify that the LTCE is treated as if it were controlled by the Parent Entity preparing these hypothetical Consolidated Financial Statements even if it does not own a Controlling Interest in the LTCE. This brings all of the LTCE's income and expenses into the Parent Entity's hypothetical Consolidated Financial Statements on a line-by-line basis so that it would be necessary to determine the share of its income allocable to other owners under the relevant accounting standard. This assumption is limited to the consolidation of the income and expense of the LTCE. This limitation is intended to avoid any confusion that might arise as a result of the assumption that its income were equal to GloBE Income. For example, substitution of the GloBE Income in the profit and loss statement may not carry through properly to a balance sheet or statement of cash flows, but this is not relevant for purposes of the exercise in Article 2.2.3.

35. The third assumption in paragraph (c), is that all of the LTCE's GloBE Income is attributable to transactions with persons that are not Group Entities. The normal process of preparing Consolidated Financial Statements eliminates income and expenses attributable to transactions between group members. This assumption is intended to clarify that the amount that should be allocated in the hypothetical allocation is the total GloBE Income of the LTCE, irrespective of whether some or all of that income was earned through transactions with Group Entities and would have been eliminated in preparing actual Consolidated Financial Statements. The entire amount of GloBE Income needs to be allocated in the hypothetical allocation, even if some or all of it is in fact derived from transactions with other Group Entities.

36. The final assumption in paragraph (d), is that all other owners (including other Constituent Entities) are treated as not holding any Controlling Interests in the LTCE. This assumption treats other Constituent Entities of the MNE Group that own an interest in the LTCE in the same manner as persons that are not Group Entities. Thus the income attributable to other Constituent Entities is treated as income attributable to a non-Group Entity. This ensures that only the income attributable to direct and indirect Ownership Interests owned by the Parent Entity is included in the Parent Entity's Inclusion Ratio.³

Article 2.2.4

37. Article 2.2.4 clarifies that in the case of a Flow-through Entity, the total GloBE income for purposes of the Inclusion Ratio is the total GloBE Income that is attributable to Ownership Interests held by Constituent Entities of the MNE Group. Thus, any amount that is allocated to a person that is not a Group Entity pursuant to Article 3.5.3 is excluded for purposes of determining a Parent Entity's Inclusion Ratio.⁴

Article 2.3 - IIR Offset Mechanism

Article 2.3.1

38. Article 2.3.1 reduces the Top-up Tax that has been allocated to a Parent Entity where two Parent Entities in the same ownership chain are required to apply an IIR to the same Top-up Tax amount and the potential for overlapping application of the IIR is not solved by the ordering rules in Articles 2.1.3 or 2.1.5. This can occur, for example, where an upper-tier Intermediate Parent Entity has a non-Controlling Interest in a lower-tier Intermediate Parent Entity, which, in turn, holds all the Ownership Interests in an LTCE. In this case, both Parent Entities will be required to apply the IIR under Article 2.1.2 in respect of the LTCE. A similar situation can arise under Articles 2.1.4 and 2.1.5 where a POPE does not hold all of the Ownership Interests of a lower-tier POPE. In this case, both POPEs in the same ownership chain are required to apply the IIR. Article 2.3.1 prevents double taxation in these situations.

Article 2.3.2

39. Article 2.3.2 determines the amount of the Top-up Tax reduction required pursuant to Article 2.3.1. Article 2.3.2 reduces the Top-up Tax that would otherwise be payable under the IIR by the upper-tier Parent Entity by the amount that is brought into charge under a Qualified IIR applied by the lower-tier Parent Entity. The reduction of Top-up Tax is limited to "the portion" of the Top-up Tax that has been allocated to the upper-tier Parent Entity and that "is brought into charge" by the lower-tier Intermediate Parent Entity or POPE. In other words, the reduction is limited to the amount of the upper-tier Parent Entity's Allocable share of the LTCE's Top-up Tax that is attributable to Ownership Interests held indirectly through the lower-tier Intermediate Parent Entity or POPE that is also obligated to apply the IIR.⁵

40. Article 2.3 reduces a Parent Entity's allocable share of a Top-up Tax by the amount allocated to a POPE or Intermediate Parent Entity located in a lower level of the ownership chain. This reduction is made at the moment of allocating the amount of Top-up Tax among Parent Entities and not after the full amount or a portion of the Top-up Tax is effectively paid.

Overview of the UTPR

41. The UTPR provides a mechanism for making an adjustment in respect of the Top-up Tax that is calculated for an LTCE to the extent that such Top-up Tax is not brought within the charge of a Qualified IIR. The UTPR is made up of three Articles:

- a. Article 2.4 sets out the UTPR adjustment mechanism to be applied by a UTPR Jurisdiction;
 - b. Article 2.5 calculates the Total Amount of an MNE Group's Top-up Tax that is allocable under the UTPR; and
 - c. Article 2.6 provides the methodology for allocating such Top-up Tax to each UTPR Jurisdiction.
42. A more detailed explanation of these provisions is set out below.

Article 2.4 - Application of the UTPR

Article 2.4.1

43. Article 2.4.1 provides that the Constituent Entities of an MNE Group shall be denied a deduction for otherwise deductible expenses (or be subject to an equivalent adjustment under domestic law) in an amount sufficient to result in the Constituent Entities located in the UTPR Jurisdiction having an additional cash tax expense equal to the UTPR Top-up Tax Amount allocated to that jurisdiction. The timing of the UTPR adjustment is addressed in Article 2.4.2.

Denial of a deduction

44. Denying a taxpayer a deduction generally increases the cash tax expense for that taxpayer by increasing the net income subject to tax in that jurisdiction. The increase in the tax payable as a result of the denial of a deduction is an amount equal to the taxpayer's rate of tax multiplied by the amount of the payment (or other expense) for which the deduction was denied. If the UTPR in a jurisdiction relies on a denial of deduction mechanism, then the amount of deductions that need to be denied under the rule can be determined by dividing the UTPR Top-up Tax Amount allocated to the jurisdiction under Article 2.6 by the taxpayer's applicable rate of tax on such income. For instance, if a Constituent Entity located in a UTPR Jurisdiction is allocated UTPR Top-up Tax Amount of 10 and the CIT rate is 25%, then denying the deduction for an otherwise deductible payment of 40 ($= 10 / 25\%$) results in an incremental cost equal to the UTPR Top-up Tax Amount allocated under the rule ($40 \times 25\% = 10$).

45. Denial of a deduction under Article 2.4.1 means the denial of a deduction for local tax purposes in respect of expenditure or similar items that are taken into account in calculating ordinary net income for tax purposes in that jurisdiction. The denied deduction need not be attributable to a transaction with another Constituent Entity. It includes the denial of an allowance for depreciation or amortisation and extends to a denial of a deduction for a purely notional expense or non-economic loss (such as a deemed interest expense). Deemed or notional expenses incurred by a PE or Main Entity in respect of the application of the arm's length principle may also be taken into account for the purposes of the UTPR provided such amounts are taken into account in calculating ordinary net income for tax purposes in that jurisdiction. A denial of a deduction does not include an item to the extent that it is already subject to separate limitation under another rule (such as an interest limitation rule). An adjustment that took the form of a denial of a deduction recorded against non-taxable income, and that therefore does not result in an additional amount of cash tax expense payable by the Constituent Entities, would not constitute a valid denial of a deduction for the purposes of a UTPR adjustment.

Equivalent adjustment

46. Article 2.4.1 further provides that the UTPR may take the form of an adjustment that is equivalent to a denial of a deduction. The UTPR does not prescribe the mechanism by which the adjustment must be made. This is a matter of domestic law implementation that is left to the UTPR Jurisdictions.

47. The adjustment under the UTPR will depend on the existing design of the domestic tax system and should be coordinated with other domestic law provisions and a jurisdiction's international obligations,

including those under Tax Treaties. For example, the adjustment under the UTPR could take the form of an additional Tax levied directly on a resident taxpayer in an amount equal to the allocated UTPR Top-up Tax Amount. Alternatively, a jurisdiction could include an additional amount of deemed income representing a reversal of deductible expenses incurred in current or prior period or a jurisdiction could choose to reduce an allowance or deemed deduction to reflect an allocation of Top-up Tax.

Additional cash tax expense

48. Whichever form the UTPR adjustment may take, Article 2.4.1 provides that the adjustment should result in an additional cash tax expense (either in the current year or, under a carry-forward mechanism, in a future year) for the Constituent Entities of the MNE Group in the jurisdiction that equals the UTPR Top-up Tax Amount allocated to this jurisdiction for each Fiscal Year. For this purpose, the additional cash tax expense is in addition to the amount that would otherwise have been paid under the ordinary domestic rules for calculating a Constituent Entity's tax liability. The resulting additional cash tax expense should be determined in respect of the taxable year in which the Fiscal Year ends, and should be due in addition to the amount of tax that would otherwise be payable for such taxable year under the normal tax rules in the jurisdiction applicable to the Constituent Entity. The additional cash tax expense increases the amount of tax that the Constituent Entity or Entities would otherwise have paid under the ordinary domestic rules for calculating their taxable income. This means that the UTPR applies after any provisions of domestic law that affect the deductibility of expenses incurred by Constituent Entities. The filing requirements associated with the tracking of the payment of the additional cash tax expense over time are addressed in Article 8.1.4(c).

49. For purposes of Article 2.4.1, an additional cash tax expense for a taxable year does not cover an amount of tax that will be payable by the Constituent Entities in respect of a future period. This means that a reduction of the amount of losses, which could otherwise be carried forward for CIT purposes, will not give rise to an additional cash tax expense for the taxable year within the meaning of this Article until a corresponding amount of income has arisen in the subsequent period.⁶ Constituent Entities located in the Jurisdiction

50. Article 2.4.1 provides that the Constituent Entities of an MNE Group shall be denied a deduction for otherwise deductible expenses (or be subject to an equivalent adjustment under domestic law) in an amount sufficient to result in the Constituent Entities located in the UTPR Jurisdiction having an additional cash tax expense equal to the UTPR Top-up Tax Amount allocated to that jurisdiction.

51. Article 2.4.1 does not prescribe how the UTPR Top-up Tax Amount is allocated among the Constituent Entities that are located in the UTPR Jurisdiction. The allocation among the Constituent Entities within a UTPR Jurisdiction should be addressed under that UTPR Jurisdiction's domestic law, which would ensure that such allocation mechanism is best coordinated with other existing domestic tax rules. The UTPR Jurisdiction may provide in its domestic law that the UTPR adjustment is imposed on only one Constituent Entity or several Constituent Entities that are located in the jurisdiction. For instance, several Constituent Entities may, for domestic tax purposes, belong to the same tax consolidated group such that the most straightforward way of making the adjustment required under the UTPR is at the level of the local tax consolidated group rather than on an entity-by-entity basis.

52. Constituent Entities may also be treated differently for this purpose, depending on whether they are wholly-owned or almost wholly-owned by the MNE Group, or whether they are partially-owned Constituent Entities. Allocating Top-up Tax to a partially-owned Constituent Entity would result in the minority interest holders of such Constituent Entity bearing indirectly a portion of the tax cost incurred by the application of the UTPR. A UTPR Jurisdiction may therefore provide that the Top-up Tax is allocated first to those Constituent Entities that are wholly-owned or almost wholly-owned by the MNE Group, in order to minimise the extent to which those minority interest holders share the burden of Top-up Tax allocated from LTCEs in which they do not have an economic interest.

53. Article 2.4.1 does not require that the additional cash tax expense is paid by the same Constituent Entities as those that were denied a deduction (or required to make an equivalent adjustment). For instance, the UTPR Jurisdiction may deny a deduction to (or impose an equivalent adjustment on) a Tax Transparent Entity, the effect of which flows through to the owners. In this case, the additional cash tax expense collected by the UTPR Jurisdiction may be levied or borne by the owners of the Tax Transparent Entity itself. As such, this additional cash tax expense may be taken into account for the purposes of assessing whether the adjustment has resulted in an additional cash tax expense that is equal to the UTPR Top-up Tax Amount.

Article 2.4.2

54. Article 2.4.2 requires that the UTPR adjustment is imposed as soon as possible and sets out a carry-forward mechanism to address the situation where the UTPR adjustment is subject to some limitations. The filing requirements associated with the carry-forward mechanism are discussed in the Commentary to Article 8.1.4(c).

The taxable year in which the Fiscal Year ends

55. The UTPR Top-up Tax Amount is calculated based on the Low-Tax profits arising during a given Fiscal Year. The earliest taxable period a UTPR adjustment can be made is the Constituent Entities' taxable year which commences during that Fiscal Year and that ends on the same day or after the Fiscal Year ends.

56. It may not be possible for a taxpayer or tax administration to know the UTPR Top-up Tax Amount that has been allocated to a jurisdiction until the GloBE Information Return is actually filed. While the GloBE Information Return is required to be filed no later than 15 months after the last day of the MNE's Fiscal Year this date may be after the due date for the tax return of the relevant taxable year. When the UTPR adjustment takes the form of a denial of a deduction, jurisdictions may require the Constituent Entities to file an amended tax return with respect to the relevant taxable year, in order to affect the relevant deductions for that year. When the adjustment requires the submission of an amended tax return, the Constituent Entities located in the UTPR Jurisdiction should not suffer any penalties for late filing or payment that results from any increase in tax payable due solely to the application of the UTPR. If it is not possible to make a full adjustment in that period, then the adjustment should be made in the following period or as soon as reasonably practicable (see also paragraphs under the carry-forward mechanism).

To the extent possible

57. Article 2.4.2 further provides that the adjustment provided under Article 2.4.1 shall apply to the extent possible with respect to the taxable year in which the Fiscal Year ends. There may be situations, however, where the UTPR adjustment will be limited in its amount for a given taxable year, for instance because there is only a limited amount of deductible expenses. Nevertheless, the UTPR adjustment shall ensure that the maximum amount is collected from the Constituent Entities as early as possible.

58. There may also be situations where the additional cash tax expense of the Constituent Entities in an MNE Group will depend on the facts and circumstances of the particular Constituent Entities on which the UTPR adjustment will be imposed. As mentioned previously, denying a deduction to a Constituent Entity that is in a loss-position may not result in an immediate additional cash tax expense for that Constituent Entity. Therefore, in order to impose the adjustment to the extent possible with respect to a given taxable year, the UTPR Jurisdiction should, to the extent possible taking into account the limitations under applicable laws, impose the adjustment in priority on those Constituent Entities that will have an immediate additional cash tax expense in that year.

Carry-forward mechanism

59. Article 2.4.2 provides a carry-forward mechanism to address the situation where the UTPR adjustment made with respect to the taxable year in which the Fiscal Year ends did not result in enough additional cash tax expense to equal the UTPR Top-up Tax Amount allocated to the jurisdiction for that Fiscal Year and will not (in the current or a future taxable year due, for example, to a reduction in net operating losses), result in enough additional cash tax expense without a further adjustment being made. In other words, the carry-forward mechanism provided under Article 2.4.2 applies if the UTPR Top-up Tax Amount allocated to a UTPR Jurisdiction exceeds the additional cash tax expense that will be incurred (in the current or a future taxable year) by Constituent Entities located in such jurisdiction as a result of the UTPR.

60. Article 2.4.2 provides that under such circumstances, it may be necessary for the difference between the UTPR Top-up Tax Amount and the amount of the additional cash tax expense of the Constituent Entities that resulted from the application of the UTPR to be carried over to the following Fiscal Year and imposed in the taxable year in which the following Fiscal Year ends, which is expected to be the immediately subsequent taxable year. This difference shall be subject to an adjustment provided in Article 2.4.1 in the next year, but remains with the jurisdiction where it was first allocated and is not subject again to the general allocation mechanism in Article 2.6 in a later year. See also below the situation where the MNE Group falls outside of the scope of the GloBE Rules or where the Constituent Entity that was allocated Top-up Tax under domestic law leaves the MNE Group.

61. When the carry-forward mechanism applies, the Constituent Entities located in the UTPR Jurisdiction should not suffer any penalties for late payment that results from the UTPR being limited in its operation in the previous years (for instance, as a result of not having sufficient deductible payments to disallow or as a result of a loss-position).

62. Article 2.4.2 also provides that the carry-forward mechanism is only applied to the extent it is necessary to impose another adjustment to ensure that the Constituent Entities will have an additional cash tax expense that equals the UTPR Top-up Tax Amount allocated to the jurisdiction. There may be situations where it is not necessary to impose another adjustment, for instance because the first adjustment will result in the Constituent Entities having – over time – an additional cash tax expense that equals the UTPR Top-up Tax Amount allocated to the jurisdiction. This may be the case when the adjustment consists of a reduction of the amount of losses and those losses can be carried forward indefinitely under the laws of the UTPR jurisdiction. However, if the losses cannot be carried forward indefinitely, the UTPR adjustment may need to be carried forward because the first adjustment will not necessarily result in an additional cash tax expense in the period during which the losses can be carried forward and a further adjustment would be necessary at the end of this period.⁷

63. Article 2.4.2 is not limited to the first taxable year that follows the one when the allocated UTPR Top-up Tax Amount could not result in an additional cash tax expense. The design of the carry-forward mechanism in Article 2.4.2 should subject the untaxed portion of the UTPR Top-up Tax Amount to the adjustment provided in Article 2.4.1 in the next year and each following year, to the extent necessary to achieve the full adjustment under Article 2.4.1. If the Top-up Tax that has been pushed-back into Article 2.4.1 does not result in an additional cash tax expense in that year then Article 2.4.2 would apply again in the following year thereby providing an indefinite carry-forward mechanism for any portion that further remains untaxed in the second and subsequent years. Article 2.4.2 also applies to the carried forward portion of the UTPR adjustment and provides that this adjustment shall apply “to the extent possible” to that following taxable year. While Article 2.4.2 provides for an indefinite carry-forward mechanism, domestic law in certain circumstances may limit the practical application of the carry-forward after a certain period of time. For example, a jurisdiction may have a domestic statute of limitation that prevents its tax administration from applying the carry-forward mechanism to its full extent. In such a situation, the Top-up Tax Amount that has not yet been collected is not allocated to another jurisdiction.

64. Article 2.4.2 is also not limited to the Fiscal Years in which the MNE Group is within the scope of the GloBE Rules or the Fiscal Years when the Constituent Entity that is allocated UTPR Top-up Tax Amount under the UTPR is part of the MNE Group. If the MNE Group's revenues fall below the threshold of Article 1.1, the Constituent Entities that were allocated UTPR Top-up Tax Amounts that did not give rise to an additional cash tax expense would still be liable for the UTPR Top-up Tax Amounts they were allocated.

65. As provided above, Article 2.4.1 does not prescribe how the UTPR Top-up Tax Amount is allocated among the Constituent Entities that are located in the UTPR Jurisdiction. Therefore, a UTPR Jurisdiction may reallocate the UTPR Top-up Tax Amount among the Constituent Entities located in that jurisdiction, in subsequent years, in order to ensure that the UTPR Top-up Tax Amount is collected as soon as possible. In such a case, the adjustment provided in Article 2.4.1 in that later year does not need to be imposed on the Constituent Entities located in that jurisdiction that were initially allocated Top-up Tax under domestic law. It may be applied against any Constituent Entities of the same MNE Group that are located in that jurisdiction, subject to the requirement in Article 2.4.2 that the adjustment shall be made to the extent possible with respect to the taxable year in which that Fiscal Year ends. Similarly, a jurisdiction may adopt a mechanism to re-allocate the UTPR Top-up Tax Amount to other Constituent Entities in the jurisdiction that remain with the MNE Group to address the situation where a Constituent Entity would be separated from the MNE Group after being allocated Top-up Tax that did not give rise to an additional cash tax expense. A UTPR jurisdiction may also provide that this Constituent Entity is still liable for the Top-up Tax that it was allocated under a jurisdiction's Qualified UTPR even if it has been separated from the MNE Group. A UTPR jurisdiction may also consider the possibility of imposing a final tax charge under the UTPR in respect of a liquidation or similar transaction that will result in there being no remaining Constituent Entities in the UTPR jurisdiction for the MNE Group.

Article 2.4.3

66. Article 2.4.3 excludes a controlled Investment Entity from the application of the UTPR. This exclusion is to avoid interfering with the intended tax neutrality of these Entities with respect to owners that are not Group Entities. Note that Investment Entities that are the UPE of the MNE Group are Excluded Entities and are therefore already outside the scope of the GloBE Rules (see Commentary to Article 1.5).

Article 2.5 - UTPR Top-up Tax Amount

67. Article 2.5 provides the methodology to determine the amount of Top-up Tax that is allocated to the UTPR Jurisdiction under the UTPR. The Total UTPR Top-up Tax Amount is determined by reference to the total amount of Top-up Tax that is due (as provided in Article 2.5.1) and that is not already subject to a Qualified IIR (as provided in Articles 2.5.2. and 2.5.3).

68. Like the IIR, the UTPR relies on the same computation made in accordance with Chapter 5 for determining the MNE Group's jurisdictional ETR and the amount of Top-up Tax. This includes the same methodology for determining GloBE Income or Loss, the amount of Covered Taxes on such income and the rules for determining the application of the Substance-based Income Exclusion. Equally, the exclusions to the definition of Constituent Entity (for example, in respect of Government Entities) apply to the ETR calculation used for determining the Top-up Tax such that no Top-up Tax would arise, or be allocable under the UTPR, in respect of these entities.

69. Having a single computation of the Top-up Tax under the IIR and the UTPR improves coordination between GloBE Rules in each jurisdiction and reduces implementation and compliance costs, while ensuring that the rules do not result in over-taxation or taxation in excess of economic profits. In addition, relying on the same Top-up Tax computation under both the IIR and the UTPR aligns the expected

outcomes under both rules, which allows the UTPR to operate as a meaningful backstop to the IIR. Failing to have a single computation of the Top-up Tax under both the IIR and the UTPR would either lead to less effective or harsher outcomes under the UTPR than under the IIR.

Article 2.5.1

70. Article 2.5.1 provides the starting point for the computation of the UTPR Top-up Tax amount and ensures that the aggregate adjustments made under the UTPR in each jurisdiction do not exceed the total amount of Top-up Tax computed for all Low-tax Jurisdictions where the MNE Group is operating.

71. In accordance with the methodology described in Article 5.2, the amount of Top-up Tax that is allocable under the UTPR is determined in respect of each Constituent Entity located in a jurisdiction where the MNE's jurisdictional ETR is below the Minimum Rate (i.e. an LTCE). The Total UTPR Top-up Tax Amount is equal to the sum of the Top-up Tax calculated for each of these LTCEs, taking into account the relevant provisions of the GloBE Rules that may affect the calculation of the Top-up Tax, such as Article 5.6 for a Minority-Owned Constituent Entity, as well as Article 7.4 or Article 7.6 for an Investment Entity. The Top-up Tax calculated for each of these LTCEs may be subject to adjustments, as provided in Articles 2.5.2, 2.5.3 and Article 9.3. In relation to JVs and JV Subsidiaries, Article 6.4.1(c) increases the Total UTPR Top-up Tax Amount taken into account for purposes of Article 2.5.1 in respect of a JV Group Top-up Tax that has not been brought into charge under a Qualified IIR. The Total UTPR Top-up Tax Amount taking into account those adjustments is then allocated amongst the UTPR Jurisdictions in accordance with the mechanism set out in Article 2.6.

Article 2.5.2

72. Article 2.5.2 and Article 2.5.3 relate to the Top-up Tax that is computed in relation to the profit of an LTCE that is subject to one or more Qualified IIRs. In that context, the IIR takes priority over the UTPR. Article 2.5.2 applies when the Parent Entity or Entities that apply the IIR collectively hold all of the UPE's Ownership Interests in the LTCE. Article 2.5.3, discussed further in the Commentary below, applies in situations where the Parent Entity or Entities that apply the IIR do not hold all of the UPE's Ownership Interests in the LTCE.

73. Article 2.5.2 provides that the Top-up Tax calculated for an LTCE shall be reduced to zero if all of the UPE's Ownership Interests in such LTCE are held directly or indirectly by a Parent Entity or Entities that are required to apply a Qualified IIR in the jurisdiction where they are located with respect to that LTCE for the Fiscal Year.

74. In the situation where no IIR applies at the UPE level, a lower level Parent Entity may be required to apply the IIR as provided under Article 2.1. If the UPE's Ownership Interest in an LTCE is held indirectly through a Parent Entity that is required to apply the IIR, then no Top-up Tax shall be allocated under the UTPR for such LTCE. Whether or not the amount of Top-up Tax may be reduced to zero in accordance with this rule is determined on an entity-by-entity basis. This means that the determination is made for each LTCE.

75. It is possible that several Parent Entities are required to apply a Qualified IIR in respect of several LTCEs. It is also possible that the Ownership Interests of a given LTCE are held by several Parent Entities that are located in the same jurisdiction and required to apply a Qualified IIR. In such a case, the Ownership Interests held by each Parent Entity are taken into account for the purposes of this test. If all of the UPE's Ownership Interests in an LTCE are held through various Parent Entities that are required to apply a Qualified IIR, no Top-up Tax shall be allocated under the UTPR in respect of such LTCE.

Application of UTPR to low tax profits in UPE Jurisdiction

76. The fact that the UPE is required to apply a Qualified IIR does not mean there is no scope for the operation of the UTPR with respect to Constituent Entities located in the UPE Jurisdiction. Where the UPE is required to apply a Qualified IIR for the Fiscal Year, it may only be required under the laws of the UPE Jurisdiction to apply the IIR in respect of PEs and subsidiaries located in other jurisdictions. In this case, no Top-up Tax will be allocated under the UTPR in respect of foreign LTCEs (i.e. located outside of the UPE Jurisdiction). There could be, however, Top-up Tax allocable under the UTPR in respect of the domestic LTCEs (i.e. located in the UPE Jurisdiction) if the ETR of the UPE Jurisdiction is below the Minimum Rate. That Top-up Tax may be reduced to zero by virtue of a Qualified Domestic Minimum Top-up Tax payable in the UPE Jurisdiction under Article 5.2.3. In the case where the UPE is required to apply a domestic IIR with respect to domestic LTCEs, the Top-up Tax may also be reduced to zero under Article 2.5.2 (see Commentary on Article 2.1.6). If the Top-up Tax arising in the UPE Jurisdiction is not reduced to zero, it will be included in the UTPR Top-up Tax Amount and allocated to each UTPR Jurisdiction in accordance with Article 2.6, discussed further in the Commentary below.

Article 2.5.3

77. It is expected that, in most cases, either the LTCEs will be wholly-owned by another Constituent Entity that is subject to a Qualified IIR (and the UTPR will not apply) or their shares will be wholly-owned by other Constituent Entities that are not subject to an IIR (and the UTPR will apply). There may be situations, however, where an Intermediate Parent Entity owns an interest in an LTCE and applies the IIR in respect of its share of the income of such LTCE under Article 2.1.2, but the application of the IIR in the Intermediate Parent Entity's jurisdiction does not result in all the Top-up Tax attributable to the UPE's Ownership Interests being brought into charge under a Qualified IIR. This situation could arise, for example where the UPE (located in a jurisdiction without a Qualified IIR) owns a larger interest in the LTCE than the Intermediate Parent Entity does. In this case, rather than excluding the whole amount of Top-up Tax from charge under Article 2.5.2, the amount of Top-up Tax levied under the Qualified IIR in the Intermediate Parent Entity's jurisdiction is deducted from the total Top-up Tax of the LTCE. This mechanism ensures that the IIR has priority over the UTPR, and avoids multiple taxation of the same low-taxed income as a result of the GloBE Rules. The Ownership Interests in the LTCE may also be held by different Parent Entities that, together, own less than the UPE's Ownership Interests in the LTCE. In such cases, the sum of Top-up Taxes that is allocated to each Parent Entity is deducted from the total Top-up Tax Amount that is allocated under the UTPR pursuant to Article 2.5.3.⁸

78. Because Article 2.5.3 reduces the Total UTPR Top-up Tax Amount by the amount of Top-up Tax subject to the IIR (rather than reducing it to zero), it leaves, within the charge to tax, low-taxed income that is beneficially owned by minority shareholders. Unlike the exclusion mechanism under Article 2.5.2, this deduction mechanism under Article 2.5.3 does not allow the MNE Group to limit the total amount of Top-up Tax payable to the allocable share of Top-up Tax that would have been allocated to the UPE if the UPE had been subject to a Qualified IIR with respect of the LTCE. Equally, it does not require a determination of whether a POPE would have been subject to tax under the IIR because of the ownership structure of the MNE Group or the Allocable Share of Top-up Tax that would have been allocated to that POPE. Instead, Article 2.5.3 deducts the tax due under an IIR from the amount of Top-up Tax that is computed on the total amount of income of the LTCE, irrespective of the UPE's Allocable Share of the Top-up Tax due in respect of the LTCE. Applying the UTPR to the total amount of Top-up Tax of an LTCE (i.e. not limited to the UPE's Ownership Interest in the LTCE) simplifies its application. It allows for a greater tax expense than the Top-up Tax that would have been collected under the IIR if it had applied at the UPE level, because it is not limited to the UPE's Allocable Share of the Top-up Tax due in respect of LTCE.

Article 2.6 - Allocation of Top-up Tax for the UTPR

79. Articles 2.6.1 to 2.6.3 describe the formula used to allocate the Total UTPR Top-up Tax Amount to each UTPR Jurisdiction on the basis of a substance-based allocation key.

Article 2.6.1

Purpose of the UTPR Percentage

80. Article 2.6.1 provides that the UTPR Top-up Tax Amount determined under Article 2.5.1 is allocated among UTPR Jurisdictions by applying their respective UTPR Percentages. Article 2.6.1 then sets out the formula for computing the UTPR Percentage of each UTPR Jurisdiction, and is drafted from the perspective of the implementing UTPR Jurisdiction. In other words, the formula determines the amount allocable to the implementing UTPR Jurisdiction.

81. The UTPR Percentage is determined on the basis of factors that reflect the relative substance of the MNE Group in each UTPR Jurisdiction. Relying on substance factors provides for a simple and transparent allocation key which facilitates the co-ordination among tax administrations. It is also expected that the jurisdictions where the MNE Group has more substance on a relative basis will be those where there is more tax capacity (such as deductible expenditure) to absorb adjustments under the UTPR. This approach, together with the exclusion mechanism in Article 2.6.3, is intended to reduce the risk of allocating Top-up Tax to a jurisdiction that does not have enough capacity to impose the UTPR adjustment.

Components of the UTPR Percentage

82. Article 2.6.1 provides that the UTPR Percentage is determined on the basis of quantitative factors that are aggregated at the jurisdictional level. These factors are based on information required in the MNE Group's CbC Reports. More specifically, Article 2.6.1 provides that the substance of UTPR jurisdictions is determined on the basis of a ratio based on the Number of Employees and the Net Book Value of Tangible Assets of the Constituent Entities that are located in those respective jurisdictions. The Number of Employees and the Net Book Value of Tangible Assets were determined to be the most appropriate for reflecting a consistent measure of substance in jurisdictions. In addition, the factors used under the UTPR provide both MNE Groups and tax administrations with bright-line measures based on existing compliance mechanisms. Using quantitative factors that can be available in CbC Reports facilitates co-ordination between UTPR Jurisdictions and minimises the risk of disputes. Other factors (such as payroll) were considered and rejected by the Inclusive Framework.

83. The Number of Employees and the Net Book Value of Tangible Assets each account for half of the UTPR percentage of the UTPR Jurisdiction. This is to reflect that substance can be measured both on the basis of the Number of Employees and the Net Book Value of Tangible Assets across jurisdictions, recognising that substance may take various forms, depending on the industry and the business model of the MNE Group. Using a 50% weight for each factor avoids favouring one of the two factors over the other in the formula.

84. The Number of Employees and the Net Book Value of Tangible Assets are defined in Article 10.1. See the Commentary on those definitions for further details.

85. The definitions provided in Article 10.1 are similar to those provided in the report on BEPS Action 13 for purposes of CbCR. Relying on similar definitions as those provided for purposes of CbC Reports minimises potential compliance costs associated with the computation of each UTPR Jurisdiction's UTPR Percentage. Article 2.6.1 does not refer to the information available in the MNE Group's CbCR and provides its own definitions to avoid the situation where there would be no basis to compute the UTPR Percentage if the MNE had not filed a CbCR. However, as a matter of simplification, an MNE Group could

prepare its CbC Reports using information from the Constituent Entities' financial accounts and the Number of Employees and Tangible Assets for each Constituent Entity located in the jurisdiction in accordance with the definition for such indicators provided under Article 10.1. A CbC Report prepared in this manner could be used for purposes of identifying the relevant amounts used to compute the UTPR Percentage.

Scope and timing of the determination of the UTPR Percentage

86. The UTPR Percentage is only computed for purposes of allocating the UTPR Top-up Tax Amount and for jurisdictions that introduced a Qualified UTPR ("UTPR Jurisdictions"). The UTPR Percentage is determined for all UTPR Jurisdictions where the MNE Group is operating, even if those UTPR Jurisdictions are Low-Tax Jurisdictions under the GloBE Rules for that MNE Group. This means that a Low-Tax Jurisdiction that is also a UTPR Jurisdiction is allocated a portion of the UTPR Top-up Tax Amount, if its UTPR Percentage is not zero (it could be zero, for instance, as a result of the provisions in Article 2.6.3). Equally, the UPE Jurisdiction itself could be a Low-Tax Jurisdiction under the GloBE Rules and be allocated a portion of the UTPR Top-up Tax Amount that arises in respect of the Constituent Entities that are located in the UPE Jurisdiction. In addition, the UPE Jurisdiction may apply a Qualified IIR with respect to the Constituent Entities of the MNE Group that are not located in the UPE Jurisdiction (in accordance with Article 2.1.6), but this would not be relevant for purposes of determining the UTPR Top-up Tax Amount that arises in respect of the Constituent Entities located in the UPE Jurisdiction.

87. Article 2.6.1 further provides that only the substance factors of Constituent Entities of the Group located in a UTPR Jurisdiction (including those of the implementing jurisdiction) are taken into account in the denominator of the fraction. Therefore, the Top-up Tax is allocated only among UTPR Jurisdictions. The substance factors of Constituent Entities that are not located in a UTPR Jurisdiction are not taken into account for purposes of the allocation key because doing so would have the effect of allocating some of the UTPR Top-up Tax Amount to jurisdictions without a Qualified UTPR. Allocating any of the UTPR Top-up Tax Amount to jurisdictions that do not have a UTPR would significantly reduce the effectiveness of the rule, because the Top-up Tax allocated to those jurisdictions would not be collected. The UTPR Percentage is determined on an annual basis, for each Fiscal Year. However, it is not expected to be significantly different from one year to the next, unless the MNE Group undertakes a significant acquisition, disposal or restructuring of its operations.

Article 2.6.2

88. Article 2.6.2 provides two types of exclusions in computing a jurisdiction's UTPR Percentage.

Paragraph (a)

89. Paragraph (a) provides for the first exclusion. The first exclusion relates to the employees of, and Tangible Assets that are held by, Investment Entities. This exclusion only matters to Investment Funds that are not the UPE. As already noted above in the Commentary to Article 2.4.3, Investment Funds and Real Estate Investment Vehicles that are the UPE are Excluded Entities and therefore, their employees and Tangible Assets are not taken into account for purposes of computing the UTPR percentage of a jurisdiction. The exclusion provided in Paragraph (a) of Article 2.6.2 relates to other controlled Investment Entities, i.e. Investment Entities that are not Excluded Entities. Paragraph (a) provides that the employees of, and Tangible Assets that are held by, controlled Investment Entities are excluded for purposes of computing a jurisdiction's UTPR percentage. The employees and assets of controlled Investment Entities are not taken into account in the allocation formula because such Entities are excluded from the scope of application of the UTPR under Article 2.4.3. Allocating some of the UTPR Top-up Tax Amount to a jurisdiction that has only Investment Entities would reduce the effectiveness of the UTPR.

Paragraph (b)

90. Paragraph (b) provides for the second exclusion. The second exclusion relates to the employees and Tangible Assets of Flow-through Entities. In practice, the substance of Flow-through Entities could give rise to the existence of a PE. As a first step, the assets and employees of the Flow-through Entity would be attributed to the PE. The assets and employees allocated to a PE are then taken into account for computing the UTPR Percentage of the jurisdiction where that PE is located.

91. However, a Flow-through Entity may not give rise to the existence of a PE, for instance because the activity or place through which the activity is carried out is not sufficient to create a PE in the jurisdiction. Some assets and employees of that Flow-through Entity may therefore remain unallocated after the assets and employees are attributed to the relevant PEs. In such a case, Paragraph (b) of Article 2.6.2 provides that the Flow-through Entity's employees and Tangible Assets that are not allocated to PEs are allocated to any Constituent Entities that are located in the jurisdiction where the Flow-through Entity was created irrespective of whether they are the Constituent Entity-owners of the Entity. This approach to allocate the employees and Tangible Assets of Flow-through Entities differs from the approach provided under Article 3.5 to allocate the Income or Loss of a Flow-Through Entity. If no Constituent Entities are located in the jurisdiction where the Flow-through Entity was created, then the employees and Tangible Assets that are not allocated to a PE are excluded from the formula.

Article 2.6.3

92. Article 2.6.3 provides that a UTPR Jurisdiction shall be excluded from the allocation mechanism provided under Article 2.6.1 when the UTPR Top-up Tax Amount allocated to that jurisdiction in a prior year has not yet resulted in an equivalent additional cash tax expense for the Constituent Entities located in that jurisdiction. Article 2.6.3 provides that, when that is the case, the UTPR Percentage for the jurisdiction is zero. This mechanism ensures that no more Top-up Tax is allocated to such a jurisdiction until it has been able to impose the requisite amount of tax. Article 2.6.3 further provides that the Number of Employees and Tangible Assets of the Constituent Entities located in such a jurisdiction are excluded from the denominator of the formula for purposes of the allocation key. This ensures that the Top-up Tax that would have been allocated to the UTPR Jurisdiction with a UTPR Percentage of zero is actually allocated to the other UTPR Jurisdictions.

93. Article 2.6.3 applies on an annual basis for each Fiscal Year when the UTPR applies. Article 2.6.3 further provides that the exclusion mechanism is specific to a particular MNE Group. This is because the capacity to impose an adjustment under the UTPR may depend on the specificities of the Constituent Entities of that MNE Group in the UTPR Jurisdiction. For instance, the capacity to impose the adjustment may be limited in the situation where the MNE Group has losses in the UTPR Jurisdiction. For the avoidance of doubt, when the rule applies to an MNE Group, it does not preclude the UTPR Jurisdiction from being allocated UTPR Top-up Tax Amount computed in respect of other MNE Groups with employees and Tangible Assets in the jurisdiction.

Article 2.6.4

94. Article 2.6.4 provides that Article 2.6.3 does not apply in circumstances where the UTPR Percentage for all UTPR Jurisdictions in which Constituent Entities of an MNE Group are located would be zero for a given Fiscal Year. This exception ensures that in such circumstances the UTPR Top-up Tax Amount is still allocated to the UTPR Jurisdictions. Because it applies in situations where all UTPR Jurisdictions may have limited capacity to impose an additional Top-up Tax, this exception acknowledges that the UTPR Top-up Tax Amount allocated in that year may also need to be carried forward as provided in Article 2.4.2 and be collected in a future year. Similarly to Article 2.6.3, Article 2.6.4 applies on an annual basis for each Fiscal Year when the UTPR applies and on an MNE Group-by-MNE Group basis.⁹

Notes

¹ The application of Article 2.1.3 is illustrated in the Examples to the Commentary on the Model GloBE Rules under Pillar Two: <https://www.oecd.org/tax/beps/tax-challenges-arising-from-the-digitalisation-of-the-economy-global-anti-base-erosion-model-rules-pillar-two-examples.pdf>.

² The application of Article 2.1.5 is illustrated in the Examples to the Commentary on the Model GloBE Rules under Pillar Two: <https://www.oecd.org/tax/beps/tax-challenges-arising-from-the-digitalisation-of-the-economy-global-anti-base-erosion-model-rules-pillar-two-examples.pdf>.

³ The application of Article 2.2.1 to 2.2.3 is illustrated in the Examples to the Commentary on the Model GloBE Rules under Pillar Two: <https://www.oecd.org/tax/beps/tax-challenges-arising-from-the-digitalisation-of-the-economy-global-anti-base-erosion-model-rules-pillar-two-examples.pdf>.

⁴ The application of Article 2.2.4 is illustrated in the Examples to the Commentary on the Model GloBE Rules under Pillar Two: <https://www.oecd.org/tax/beps/tax-challenges-arising-from-the-digitalisation-of-the-economy-global-anti-base-erosion-model-rules-pillar-two-examples.pdf>.

⁵ The application of Article 2.3.2 is illustrated in the Examples to the Commentary on the Model GloBE Rules under Pillar Two: <https://www.oecd.org/tax/beps/tax-challenges-arising-from-the-digitalisation-of-the-economy-global-anti-base-erosion-model-rules-pillar-two-examples.pdf>.

⁶ The application of Article 2.4.1 is illustrated in the Examples to the Commentary on the Model GloBE Rules under Pillar Two: <https://www.oecd.org/tax/beps/tax-challenges-arising-from-the-digitalisation-of-the-economy-global-anti-base-erosion-model-rules-pillar-two-examples.pdf>.

⁷ The application of Article 2.4.2 is illustrated in the Examples to the Commentary on the Model GloBE Rules under Pillar Two: <https://www.oecd.org/tax/beps/tax-challenges-arising-from-the-digitalisation-of-the-economy-global-anti-base-erosion-model-rules-pillar-two-examples.pdf>.

⁸ The application of Article 2.5.3 is illustrated in the Examples to the Commentary on the Model GloBE Rules under Pillar Two: <https://www.oecd.org/tax/beps/tax-challenges-arising-from-the-digitalisation-of-the-economy-global-anti-base-erosion-model-rules-pillar-two-examples.pdf>.

⁹ The application of Article 2.6.4 is illustrated in the Examples to the Commentary on the Model GloBE Rules under Pillar Two: <https://www.oecd.org/tax/beps/tax-challenges-arising-from-the-digitalisation-of-the-economy-global-anti-base-erosion-model-rules-pillar-two-examples.pdf>.

3 Computation of GloBE Income or Loss

1. Chapter 3 of the GloBE Rules sets out the computation of GloBE Income or Loss for each Constituent Entity. The starting point for this computation is the Financial Accounting Net Income or Loss of the Constituent Entity calculated in accordance with the rules of Article 3.1. This amount is then adjusted under Article 3.2 for common differences between financial accounting and taxable income in order to reflect intended policy outcomes (such as the exclusion of dividend income and adding-back of illegal payments). Article 3.3 then provides a specific exclusion for International Shipping Income and Qualified Ancillary International Shipping Income. The Chapter also sets out rules for allocating income between a Main Entity and a PE (Article 3.4) and rules for allocating income derived through a Flow-through Entity to other Constituent Entities (Article 3.5). Taken together, Chapter 3 operates to convert Financial Accounting Net Income or Loss to the GloBE Income or Loss, which is then utilised in subsequent Chapters to determine the ETR and Excess Profits for purposes of determining whether Top-up Tax is payable with respect to a particular jurisdiction

Article 3.1 - Financial Accounts

Article 3.1.1

2. Article 3.1.1 requires that the computation of GloBE Income or Loss begins with the Financial Accounting Net Income or Loss of the Constituent Entity. That amount is adjusted for the items of income, gain, loss and expense that are set out in Articles 3.2 to Article 3.5.

Article 3.1.2

3. Article 3.1.2 defines Financial Accounting Net Income or Loss. It is the net income or loss determined for the Constituent Entity basis by taking into account all of the Entity's income and expenses, including from transactions with other members of the Group and including the income tax expense. Stated differently, the starting point for calculating GloBE income or loss, is the bottom-line net income or loss of the Group Entity before making any consolidation adjustments that would eliminate income or expense attributable to intra-group transactions. Elimination of income and expenses from intra-group transactions that occur in the accounting consolidation process are not taken into account in the computation of a Constituent Entity's Financial Accounting Net Income or Loss. In addition, adjustments to income or expense attributable to purchase accounting for an acquired business (irrespective of when the business was acquired) that are reflected in the MNE Group's consolidated accounts, rather than a Constituent Entity's separate accounts, are not taken into account in the computation of a Constituent Entity's Financial Accounting Net Income or Loss. Items of income and expense, other than those attributable to purchase accounting, that are reflected in the consolidated accounts, rather than a Constituent Entity's separate accounts, may be taken into account in computing the Constituent Entity's Financial Accounting Net

Income or Loss and GloBE Income or Loss only to the extent they can be reliably and consistently traced to the relevant Entity (e.g. stock-based compensation).

4. In the case of a business combination for which the acquisition date is prior to 1 December 2021, the Constituent Entity may use the carrying value reflected in its separate accounts after the application of “push down” accounting, if permitted, or the carrying value of assets and liabilities determined as per the financial accounting standard used by the UPE, but only if the MNE Group does not have sufficient records to determine its Financial Accounting Net Income or Loss with reasonable accuracy based on the unadjusted carrying values of the acquired assets and liabilities. In such cases, however, the Constituent Entity must also take into account any deferred tax assets and liabilities arising in connection with the purchase in the computation of its Financial Accounting Net Income or Loss and its Adjusted Covered Taxes. A Constituent Entity may not take into account “push down” adjustments to the carrying value of assets and liabilities attributable to the purchase of a business if the acquisition date is on or after 1 December 2021.

5. The net income or loss of the Constituent Entity has to be determined using the accounting standard that was used to determine the Constituent Entity’s income or loss in preparing the Consolidated Financial Statements (except as provided in Article 3.1.3, discussed below). In general, Consolidated Financial Statements are the financial statements prepared by a UPE in accordance with an Acceptable Financial Accounting Standard. Article 10.1 contains a list of international and national accounting standards that are Acceptable Financial Accounting Standards.

6. If a UPE does not have financial statements prepared in accordance with one of those standards, its Consolidated Financial Statements are the statements that are, or would be prepared, using an Authorised Financial Accounting Standard, which is required to be adjusted to prevent Material Competitive Distortions, as necessary. Article 10.1 includes both the definitions of an Authorised Financial Accounting Standard and a Material Competitive Distortion. An Authorised Financial Accounting Standard is an accounting standard that is permitted by the Authorised Accounting Body of the jurisdiction in which an Entity is located. An Authorised Accounting Body is defined in Article 10.1 as the body with legal authority in a jurisdiction to prescribe, establish, or accept accounting standards for financial reporting purposes. Authorised Financial Accounting Standards are thus identified by the Authorised Accounting Body of a particular jurisdiction and not all Acceptable Financial Accounting Standards will be Authorised Financial Accounting Standards in a given jurisdiction. Note that only Authorised Financial Accounting Standards that are not Acceptable Financial Accounting Standards may require adjustment for Material Competitive Distortions, whereas the list of international and national accounting standards that are Acceptable Financial Accounting Standards do not require such adjustment.

7. There are a number of advantages to using the information used to prepare the Consolidated Financial Statements as the starting point for calculating GloBE Income or Loss. It results in greater consistency than using local accounting standards for Constituent Entities located in different jurisdictions, such as different materiality thresholds for certain transactions and different criteria for classifying research and development expenditures, and avoids the risk of arbitrage from the use of different accounting standards. Further, it reduces compliance costs, by drawing on information that is already being prepared for reporting purposes and may benefit from being subject to review by an independent auditor.

8. Neither the Financial Accounting Net Income or Loss nor the adjustments set out in Article 3.2 are proportionally reduced for income or loss attributable to minority interests in the Constituent Entity itself. Instead, Top-up Tax attributable to Ownership Interests held by non-Constituent Entities is effectively excluded from the determination of a Parent Entity’s Allocable Share of the Top-up Tax under the IIR via the Inclusion Ratio determined in Article 2.2.

9. Because the rules for computing GloBE Income or Loss begin with the Financial Accounting Net Income or Loss reflected in the profit and loss statement, income or expense items that are reported under certain financial accounting standards in the Other Comprehensive Income (OCI) section of the

Consolidated Financial Statements (rather than in the profit and loss statement) are generally excluded from the computation of GloBE Income or Loss. The items included in OCI may include gains and losses on certain debt and equity investments, foreign currency exchange gains and losses, and changes in liabilities under pension plans. Included Revaluation Method Gain or Loss, which is discussed in the Commentary to Article 3.2.1(d), is an exception to the general rule that items reflected in OCI are excluded from the computation of GloBE Income or Loss.

10. Some items that are included in OCI may also be included in the computation of taxable income in the jurisdiction in which the Constituent Entity is located and thus the Constituent Entity may accrue current or deferred tax liabilities associated with those items. Nevertheless, these items are generally excluded from GloBE Income or Loss, and pursuant to Article 4.1.3(a), if any taxes associated with income reported in OCI and excluded from GloBE Income or Loss are included in the Constituent Entity's current tax expense (instead of reflected in OCI), they must be removed from the Constituent Entity's Adjusted Covered Taxes..

11. In other cases, items of income or loss reported in OCI are "recycled" through the profit and loss statement, meaning that they are included in the profit and loss statement at a later date. To the extent these items are also included in the taxable income of the Constituent Entity, these items will only be expected to give rise to a temporary or timing difference between the local tax base and the Financial Accounting Net Income or Loss. In certain cases, however, they could give rise to a permanent difference when included in the profit and loss statement at a later date, but not the taxable income of the Constituent Entity.

12. Because the accounting standards used to prepare the Consolidated Financial Statements include a materiality threshold, minor or inconsequential deviations from a strict application of the UPE's accounting standard in the computation of a particular Constituent Entity's Financial Accounting Net Income or Loss for purposes of preparing the Consolidated Financial Statements do not need to be adjusted when such threshold is not exceeded. The financial accounting auditor's acceptance of a deviation in the Consolidated Financial Statements without a qualification to the auditor's opinion is good evidence that the difference is immaterial. On the other hand, an auditor's opinion that contains a qualification with respect to the accounting treatment of a specific item or items of income and expense is relevant, but not conclusive, evidence that the deviation is material. In addition, if a UPE uses an accounting standard permitted by the Authorised Accounting Body in the UPE Jurisdiction and the Authorised Accounting Body permits the UPE to apply a different accounting standard to compute the Financial Accounting Net Income or Loss of foreign Constituent Entities (for purposes of preparing the Consolidated Financial Statements), the Financial Accounting Net Income or Loss computed for those foreign Constituent Entities using the different accounting standard need not be adjusted to strictly conform to the UPE's accounting standard.

Article 3.1.3

13. Article 3.1.3 is intended to address a situation where the Constituent Entity maintains its entity-level financial accounts using an accounting standard that is different from the standard used in the preparation of the UPE's Consolidated Financial Statements and it is not reasonably practicable to accurately calculate its Financial Accounting Net Income or Loss in conformity with the accounting standard used by the UPE in the Consolidated Financial Statements. In this event, the Financial Accounting Net Income or Loss may be determined using another Acceptable Financial Accounting Standard or Authorised Financial Accounting Standard (adjusted for Material Competitive Distortions). This rule is not expected to apply in many cases because an MNE Group will typically have mechanisms in place to convert a subsidiary's entity-level accounts to the UPE's accounting standard in connection with the preparation of the Consolidated Financial Statements. In those circumstances, it is reasonably practicable to accurately calculate the Constituent Entity's Financial Accounting Net Income or Loss based on the

standard used in the preparation of the UPE's Consolidated Financial Statements. However, the rule could apply, for example, when the MNE Group has undertaken a recent acquisition of a group of Entities that have historically used a different accounting standard to that of the acquiring MNE Group and it is not reasonably practicable for the MNE Group to convert the acquired Entities' financial accounting systems from their historical financial accounting standard to the UPE's standard.

14. Where it is not reasonably practicable to use the UPE's financial accounting standard to compute the Constituent Entity's Financial Accounting Net Income or Loss, the use of an alternative accounting standard is further limited by three conditions. The first condition of Article 3.1.3 is that the financial accounts of the Constituent Entity are maintained based on an Acceptable Financial Accounting Standard or Authorised Financial Accounting Standard. Financial accounts maintained under an Authorised Financial Accounting Standard must be adjusted for Material Competitive Distortions. A Constituent Entity may not use an accounting standard under Article 3.1.3 other than the one used in its financial accounts. If the Constituent Entity does not maintain its financial accounts based on an Acceptable Financial Accounting Standard or Authorised Financial Accounting Standard, it must compute its financial accounting income using the UPE's financial accounting standard, notwithstanding any practical difficulties.

15. The second condition under Article 3.1.3 is that the information in the financial accounts maintained according to the other accounting standard is reliable. This means that there must be appropriate mechanisms in place to ensure that the information is recorded accurately. In this regard, the financial accounting internal controls and accounting processes employed by the Constituent Entity must be tested and deemed acceptable to the financial accounting auditor pursuant to generally accepted auditing standards applicable in the location of the UPE or the Constituent Entity (in the case of a Flow-through Entity in the jurisdiction of creation). If the Constituent Entity does not meet this requirement in a Fiscal Year, it must determine the actual income and expenses for that year and develop and implement mechanisms to ensure that the information in the accounts is reliable.

16. The final condition of Article 3.1.3 is that the use of the other accounting standard must not result in permanent differences in excess of EUR 1 million from the financial accounting standard of the UPE. If the permanent differences, in the aggregate, exceed EUR 1 million, the treatment of the relevant items in the Constituent Entity's financial accounts must be adjusted to conform to the treatment that would apply under the UPE's financial accounting standard. This condition only applies to permanent differences between the accounting standards. For example, if a financial instrument is treated as debt under the UPE's financial accounting standard and equity under the other accounting standard, the UPE's standard will reflect payments received on the instrument in the financial accounting net income and the other standard will not. This will result in a permanent difference in the Financial Accounting Net Income or Loss of the holder of the instrument. Timing differences, including differences in the financial accounting period used under the different accounting standard, are not subject to this condition.

Article 3.2 - Adjustments to determine GloBE Income or Loss

17. Once the Financial Accounting Net Income or Loss of a Constituent Entity is determined, it is adjusted for certain book to tax differences (that is, differences between financial accounting results and taxable income results) that are common in Inclusive Framework jurisdictions. Differences between financial accounting standards and tax accounting rules generally can be categorised as giving rise either to permanent differences that will not reverse in a future period or temporary differences (i.e., timing differences) that will reverse in a future period. The adjustments required in Article 3.2 are generally related to permanent differences between the treatment required under financial accounting rules and local tax rules. Temporary differences are addressed in Chapter 4.

18. In the commentary below, the adjustments are described as either positive amounts or negative amounts. An adjustment described below as a positive amount will increase the financial accounting net

income and decrease the financial accounting net loss. These items are generally attributable to an adjustment that has the effect of increasing revenue or other income or decreasing an expense. An adjustment described below as a negative amount will decrease the financial accounting net income and increase the financial accounting net loss. These items are generally attributable to an adjustment that has the effect of reducing revenue or other income or increasing an expense. Many of the categories of adjustments described below are an aggregate of several similar adjustments, some of which may be positive amounts and others negative amounts. Only two categories reliably produce a positive or negative adjustment: Policy Disallowed Expenses (positive) and Excluded Dividends (negative). Although some other categories will tend toward a consistently positive or negative adjustment, they may produce the opposite adjustment depending upon the facts in the particular Fiscal Year.

19. To the extent an adjustment required by Article 3.2 excludes an amount of income from the GloBE Income or Loss computation, any Covered Taxes associated with that income must also be excluded from Adjusted Covered Taxes pursuant to Article 4.1.3(a).

Article 3.2.1

20. Article 3.2.1 sets out the adjustments to the Financial Accounting Net Income or Loss that are required in the computation of each Constituent Entity's GloBE Income or Loss. These adjustments bring the Constituent Entity's GloBE Income or Loss more into alignment with the computation of taxable income under a typical CIT (for example, exclusion of equity method income or loss from a non-Controlling Interest in a corporation) and prevent double taxation of the MNE Group's income under the GloBE Rules (for example, exclusion of dividends received from Constituent Entities).

21. Each Inclusive Framework jurisdiction has its own unique combination of additions to and exclusions from financial accounting net income or loss to arrive at taxable income under its domestic tax law. Because financial accounts are utilised as the starting point for determining the GloBE Income or Loss for all Constituent Entities wherever located, certain permanent differences will arise between the taxable income and the GloBE Income or Loss computed for some Constituent Entities. Such permanent differences are to be expected as a natural consequence of a common tax base for the GloBE Rules, and it would not be possible or desirable, from either a policy or a design perspective, to develop a comprehensive set of adjustments to bring the GloBE Income or Loss fully into line with the taxable income calculation rules of all Inclusive Framework members. Indeed, many permanent differences, such as the exclusion of income from the tax base, will give rise to the types of low-tax outcomes that the GloBE Rules are intended to address. Nevertheless, some adjustments to financial accounts are appropriately based on the policies of the GloBE Rules and tax policy more generally, such as the treatment of bribes and fines. While the number of adjustments have been kept at a minimum to minimise complexity, the adjustments set out in Article 3.2 reflect cases that are sufficiently material and widely accepted in Inclusive Framework jurisdictions. Nine adjustments are required by Article 3.2.1. Each adjustment is discussed in turn.¹

Paragraph (a) - Net Taxes Expense

22. Paragraph (a) adds back the Net Taxes Expense to the Constituent Entity's Financial Accounting Net Income or Loss. The definition of Net Taxes Expense is in Article 10.1. The definition covers a range of different types of tax expense items (or adjustments to those items) that would ordinarily be taken into account in the calculation of net income for accounting purposes but which must be added-back to GloBE Income or Loss in order to produce a reliable ETR calculation for GloBE purposes. For example, while income taxes and other covered tax liabilities that accrue during the Fiscal Year can be expected to reduce net income for financial reporting purposes, these tax expenses must be added-back to income in order to accurately calculate the tax on total income for the year for GloBE purposes. An entity that incurs Covered Taxes of 20 on 100 of income has an ETR of 20% ($=20/100$) for GloBE purposes and not an ETR of 25% ($=20/80$).

23. The adjustment for Net Taxes Expense will typically be a positive amount (i.e. an increase to GloBE income) because it adds back taxes in respect of net income. As explained below, however, the adjustment will be a negative amount where the Constituent Entity incurs a net loss that results in the creation of a deferred tax asset.

24. Article 10.1 provides that a Constituent Entity's Net Taxes Expense is the net amount of:

- a. any Covered Taxes accrued as an expense and any current and deferred Covered Taxes included in the income tax expense, including Covered Taxes on income that is excluded from the GloBE Income or Loss computation;
- b. any deferred tax asset attributable to a loss for the Fiscal Year;
- c. any Qualified Domestic Minimum Top-up Tax accrued as an expense;
- d. any taxes arising under the GloBE Rules accrued as an expense; and
- e. any Disqualified Refundable Imputation Tax accrued as an expense.

25. Paragraphs (a) and (b) of this definition describe tax items that will generally be taken into account in determining an entity's net income but should generally be added back to income for GloBE purposes. Items (c) and (d) describe tax liabilities accrued under a Qualified Domestic Minimum Top-up Tax or the GloBE Rules themselves which should not be treated as expenses in determining the GloBE tax base. Item (e) specifically identifies Disqualified Refundable Imputation Taxes as an item that needs to be added back to the calculation of GloBE Income. As described further in the Commentary to Article 10.1, a Disqualified Refundable Imputation Tax is a tax that is initially imposed on the income of a Constituent Entity but is excluded from the definition of Covered Taxes because the tax is refunded (or refundable) upon distribution of that income to the owner.

Covered Taxes

26. Any Covered Taxes that were deducted in the computation of Financial Accounting Net Income or Loss whether as an above-the-line expense or as a below-the-line income tax, must be added back to the determination of GloBE Income or Loss. As a matter of general tax policy, creditable taxes are generally not deductible against taxable income. Allowing a deduction and a credit for the same taxes would effectively provide a double benefit for the same taxes. Covered Taxes are included in the numerator of the ETR fraction, which reduces the potential tax liability under the GloBE Rules in the same manner as a tax credit. It would be inconsistent with the policy of the GloBE Rules to also allow them as a deduction in the computation of the GloBE Income or Loss because GloBE Income or Loss is tantamount to taxable income under an ordinary income tax and also serves as the denominator of the ETR fraction. This adjustment is a positive amount that increases the Net Taxes Expense adjustment.

27. Covered Taxes attributable to income that is excluded from the computation of GloBE Income or Loss must also be added back to Financial Accounting Net Income or Loss to prevent the tax attributable to the excluded income from being allowed as a deduction in the computation of the GloBE Income or Loss.

28. For example, assume that a Constituent Entity has 120 of income in Year 1 and pays 12 of Covered Taxes on that income pursuant to a 10% statutory tax rate. The Constituent Entity's Financial Accounting Net Income or Loss is 108 (= 120 – 12). Assume further that 20 of income is excluded from the computation of GloBE Income and 2 of the Covered Taxes is attributable to the excluded income. Thus, the Constituent Entity's GloBE Income should be 100 and the Adjusted Covered Taxes should be 10, which produces a 10% ETR. If only the 10 of tax attributable to the GloBE Income were added back to the 108 of net income, the GloBE Income would be 98 (= 108 + 10 – 20) after the excluded income is removed from the computation. The 2 of tax attributable to the excluded income would essentially be allowed as a deduction in the computation of GloBE Income and would produce a 10.2% ETR. By adding back all 12 of the

Covered Taxes for the Fiscal Year, the GloBE Income is correctly determined as 100 (= 108 + 12 – 20) and the ETR is correctly determined as 10%.

29. Covered Taxes of a Constituent Entity generally refer to Taxes accrued in the financial accounts with respect to that Constituent Entity's taxable income, or in some cases, its retained earnings or equity. For the avoidance of doubt, an amount withheld by a Constituent Entity in respect of Taxes imposed on another person (i.e. the foreign payee) in lieu of a generally applicable CIT, is an expense and not Covered Taxes of the Constituent Entity. Accordingly, there is no need to make an adjustment in respect of such an amount in the determination of the Constituent Entity's GloBE Income. This is the case regardless of whether a foreign payee requires a Constituent Entity, being the payer, to gross-up the payment to reimburse the foreign payee for the withholding tax imposed by the jurisdiction of the Constituent Entity on the foreign payee's income.

Deferred Tax Asset

30. A deferred tax asset arising in respect of a loss does not represent Tax paid in advance of the recognition of income for tax purposes. Instead, it arises because a portion of the total loss, i.e. the excess of expenses over income, effectively creates an asset that can be used against tax liability on income arising in the future. As such, it reduces the economic effect of the business loss. The deferred tax asset is determined by reference to the pre-tax accounting loss. Accordingly, the amount of the deferred tax asset must be treated as a negative amount in the computation of the Net Taxes Expense adjustment. For example, A Co incurs an economic loss of 100 in Year 1 and records a deferred tax asset of 15 (assuming a 15% corporate tax rate). The net loss recorded for financial accounting purposes will be 85, given that an asset of 15 has been generated in the same year by virtue of the local tax loss carry-forward. In order to accurately reflect the loss for GloBE purposes, the 15 is taken into account in the Net Taxes Expense adjustment as a negative amount. However, to the extent a deferred tax asset is taken into account in the adjustment for Covered Taxes pursuant to paragraph (a) of the definition of Net Taxes Expense, it is not taken into account under paragraph (b).

Qualified Domestic Minimum Top-up Taxes

31. The same reasoning against allowing a deduction for Covered Taxes applies in the case of Qualified Domestic Minimum Top-up Taxes because those taxes also reduce the MNE Group's potential Top-up Tax liability, albeit as a direct reduction to Top-up Tax liability under Article 5.2.3 rather than as part of the ETR computation under Article 5.2.1. These Taxes are positive amounts that increase the Net Taxes Expense adjustment. A domestic minimum tax that is not a Qualified Domestic Minimum Top-up Tax but that meets the definition of a Covered Tax and that is deducted in the computation of Financial Accounting Net Income or Loss must be added back under paragraph (a).

GloBE Taxes

32. Top-up Taxes arising under the GloBE Rules that have been accrued in the financial statements must be added back to the Financial Accounting Net Income or Loss. The amount of tax paid under a Tax regime does not reduce the base on which that Tax is levied. The adjustment for Top-up Taxes arising under the GloBE Rules applies irrespective of whether the taxes are due to an accrual of the estimated liability for the current Fiscal Year or an adjustment to the actual liability for a previous Fiscal Year. These Taxes are positive amounts that increase the Net Taxes Expense adjustment. For example, an MNE Group may report its expected Top-up Tax liability for a Fiscal Year in its financial statements. Such amount must be added back to prevent overstating the ETR, as the amount of GloBE Income would otherwise be understated.

Disqualified Refundable Imputation Taxes

33. Disqualified Refundable Imputation Taxes are not Covered Taxes. However, they must be added back to the Financial Accounting Net Income or Loss because such Taxes are essentially deposits that the MNE Group can have refunded at the time of its choosing by simply distributing a dividend. As such, they are not properly treated as an expense in the computation of GloBE Income or Loss. When Disqualified Refundable Imputation Taxes are paid or accrued and included as an expense in the Financial Accounting Net Income or Loss, they must be added back. This would be a positive amount that increases the Net Taxes Expense adjustment. If on the other hand, Disqualified Refundable Imputation Taxes are refunded or credited to the MNE group in a Fiscal Year and treated as an income item or a reduction to a tax expense in the Financial Accounting Net Income or Loss, the amount must be removed from income or added back to the tax expense. This would be a negative amount that decreases the Net Taxes Expense adjustment.

Paragraph (b) - Excluded Dividends

34. Dividends and distributions from controlled Entities and Entities reported under the equity method will generally be excluded from the calculation of the group's consolidated income. The underlying income or loss of Entities that are consolidated on a line-by-line basis and Entities that are accounted for under the equity method is included directly in the Group's income. Consolidated Financial Statements exclude distributions from these Entities to avoid double-counting of the same income. The GloBE Rules, however, generally require the GloBE Income or Loss and Covered Taxes of Constituent Entities to be determined starting with the separate Financial Accounting Net Income or Loss of the Constituent Entity. Accordingly, the starting point for a Constituent Entity's income for financial accounting purposes would be to include intra-group dividends, including distributions received or accrued in respect of an Ownership Interest held in a Flow-Through Entity, as well as dividends received in respect of Ownership Interests in JVs, associated Entities, and other Entities, including dividends on Portfolio Shareholdings.

35. The taxation of these dividends and other distributions received by a Constituent Entity varies from one jurisdiction to the next. A significant number of Inclusive Framework jurisdictions provide for a credit, exemption or some other form of tax relief for dividends under local law. In many cases the availability of this relief depends on the size of the shareholding, the duration of the shareholding period, or both. The precise tax treatment may also depend on the residence and nature of the distributing and receiving Entity as well as the nature of the distribution itself. For example, a dividend received from a non-resident may be taxed differently from a dividend received from a resident and a receipt of a distribution may be taxed differently from a share buyback. In order to ensure consistency and avoid the significant complexity that would result from reconciling these differences in treatment, the GloBE Rules require MNE Groups to apply a consistently bright-line test that builds on the components found in the participation exemptions applied by a number of Inclusive Framework jurisdictions.

36. Article 3.2.1(b) adjusts a Constituent Entity's Financial Accounting Net Income or Loss by reducing that Net Income (or increasing the Loss) by the amount of any Excluded Dividends received during the Fiscal Year. In general terms, Excluded Dividends are dividends or other distributions paid on shares or other equity interests where (i) the MNE Group holds 10% or more of the Ownership Interests in the issuer or (ii) the Constituent Entity has held full economic ownership of the Ownership Interest for a period of 12 months or more. Paragraph (b) is intended to provide for a broad exemption for dividends that aligns with the operation and scope of participation exemptions in many IF jurisdictions and covers both substantial and long terms shareholdings, while, at the same time, ensuring that the exclusion does not provide unintended benefits for dividend income received by a Constituent Entity as part of its trading activity.

37. Excluded Dividends are defined in Article 10.1 as dividends or other distributions received or accrued in respect of an Ownership Interest, except for a Short-term Portfolio Shareholding and an

Ownership Interest in an Investment Entity subject to an election under Article 7.6. The exception that applies to these two categories of Ownership Interest is further described below.

Short-term Portfolio Shareholding

38. The dividend exclusion rule under the GloBE Rules provides an exception for dividends received from an Entity (i) in which the MNE Group owns a low percentage of that Entity's Ownership Interests (i.e. a "Portfolio Shareholding"), where (ii) the Constituent Entity has economically owned such Ownership Interest for a short period of time (referred to as "Short-term Portfolio Shareholdings"). This means that dividends received or accrued from Short-term Portfolio Shareholding are included in the GloBE Income or Loss of the Constituent Entity. The following table summarises which dividends or other distributions received or accrued in respect of an Ownership Interest (other than an Ownership Interest in an Investment Entity that is subject to an election under Article 7.6, which is addressed in the next section), are includible in the GloBE Income or Loss of the Constituent Entity that received or accrued them:

| Dividends or other distributions received or accrued in respect of: | Portfolio Shareholding (i.e. carrying rights to less than 10% of the profits, capital, reserves or voting rights of the distributing entity) | Non-Portfolio Shareholding (i.e. carrying rights to at least 10% of the profits, capital, reserves and voting rights of the distributing entity) |
|---|--|--|
| Short-term shareholding (i.e. economically held for less than one year) | Included dividend | Excluded Dividend |
| Non- Short-term shareholding (i.e. economically held for at least one year) | Excluded Dividend | Excluded Dividend |

39. A Portfolio Shareholding in a corporation is defined in Article 10.1 as an Ownership Interest that carries rights to less than 10% of the profit, capital, reserves or voting rights of that Entity at the date of the distribution or disposition. This means that only an Ownership Interest that carries right to at least 10% of the profit, capital, reserves and voting rights of that Entity is considered as a non-portfolio shareholding. Voting rights, in addition to rights to profits, capital and reserves are taken into account for purposes of defining whether an Ownership Interest is a Portfolio Shareholding because they may reflect the involvement of the shareholder in the Entity.

40. All of the Ownership Interests which carry the same rights (i.e. profit, capital reserves or voting rights) in an Entity held by the MNE Group are aggregated for purposes of applying the 10% threshold test in respect of those Ownership Interests. The definition of Ownership Interest provided in Article 10.1 further requires that the interest in the underlying right is an equity interest, i.e. any shares, interests, participation, or other equivalents of that Entity which are characterised as equity under the Acceptable or Authorised Financial Accounting Standard used in the Consolidated Financial Statements.

41. A Portfolio Shareholding is a Short-term Portfolio Shareholding if the Constituent Entity that receives or accrues the dividends or other distributions has economically held the Ownership Interest for less than one year at the date of the distribution. A Constituent Entity is considered as holding "economically" a Portfolio Shareholding when it has (or is entitled to) all or substantially all the benefits and burdens of ownership, including rights to profits, capital, reserves, or voting carried by its Ownership Interests, and has not renounced or transferred such rights under another arrangement over the tested period. Whether a Constituent Entity has (or is entitled to) all or substantially all the benefits and burdens of ownership is determined on the basis of facts and circumstances.

42. There could be a discrepancy between the extent of the ownership held throughout the holding period and at the date of the distribution, whereby the dividend received at the date of the distribution may not necessarily reflect the extent of the rights that were held during the holding period. Ordinarily, the dividends or other distributions that are accrued at the date of the distribution reflect the economic ownership of the shareholding that is held at that date. Therefore, the economically held test addresses the potential discrepancy that could arise during the period and at the date of the distribution and provide a requirement that those Portfolio Shareholding are economically held for at least one year to be excluded from the GloBE Income or Loss.

43. Whether the Constituent Entity has economically held the Portfolio Shareholding for one year is tested on the date of the distribution of the dividends. Fluctuations of the Ownership Interest held in an Entity should be taken into account for that purpose. In this respect, the disposition of an Ownership Interest in a particular class of shares is deemed to be a disposition of the most recently acquired Ownership Interests of the same class that were acquired the last, for simplification purposes. For that purpose, a class of shares means the shares issued by the distributing entity that carry the same rights such that they are inter-changeable with each other. For example, an Entity that has issued common shares with rights to profits and net assets upon dissolution and preferred shares that are entitled to a dividend of EUR 100 each year and redeemable in 10 Years for EUR 2 000 has two classes of stock. Accordingly, dispositions of preferred shares do not affect the determination of the holding period of the common shares.

44. The Constituent Entity is considered as having held the relevant Ownership Interest for one year if it has held that Ownership Interest for an uninterrupted period of at least 12 months. The requirement only relates to the Ownership Interest in respect of which a distribution is received or accrued and does not require a further determination of whether the distribution was funded by another distribution to which the same condition would apply. For example, a Constituent Entity that receives a distribution in respect of an Ownership Interest in a mutual fund must determine its holding period for that interest, but need not determine how long the mutual fund held the equity interest that was the source of the distributed profits. This condition applies to each Constituent Entity holder separately and in respect of the same class of shares such that the dividends received or accrued in respect of the same class of shares that were held for a year or more are exempted, whereas other dividends are not. Unlike the 10% threshold test, the ownership period requirement applies on a Constituent Entity-by-Constituent Entity basis, which means that an intra-group transfer of shares would be considered as an interruption of the holding period. The holding period would not be considered as interrupted, however, in the case of a GloBE Reorganisation between Constituent Entities.

45. In relation to Short-term Portfolio Shareholdings, the dividend income is not included in the adjustment for Excluded Dividends and thus would be included in the GloBE Income or Loss. Any Taxes paid under local law in respect of those dividends would be included in the Adjusted Covered Taxes (the numerator) of the ETR calculation under Article 4.1.1. The treatment of dividends on Short-term Portfolio Shareholdings applies equally to dividends on stock in domestic and foreign corporations. Including dividends on Short-term Portfolio Shareholdings in the GloBE Income or Loss eliminates the need to exclude the related expenses and the need for rules to determine the scope and amount of those related expenses. Although local tax rules typically disallow deductions for expenses associated with income that is excluded from taxable income, for simplicity, the GloBE Rules do not disallow expenses related to Excluded Dividends and therefore rules to determine the scope and amount of those related expenses are unnecessary.

Ownership Interest in an Investment Entity that is subject to an election under Article 7.6

46. The definition of Excluded Dividends in Article 10.1 provides that dividends or other distributions received or accrued in respect of an Ownership Interest in an Investment Entity that is subject to an election under the Taxable Distribution Method set out in Article 7.6 are not Excluded Dividends. Accordingly, those dividends or other distributions must be included in the computation of GloBE Income or Loss of the Constituent Entity-owner pursuant to the election since such dividends are not Excluded Dividends once the election has been made. The election is discussed in greater detail in the Commentary to Article 7.6.

Paragraph (c) - Excluded Equity Gains or Losses

47. Paragraph (c) adjusts for a Constituent Entity's Excluded Equity Gain or Loss.

48. Excluded Equity Gains or Losses are defined in Article 10.1. The term encompasses three categories of gain or loss attributable to an Ownership Interest:

- a. gains and losses from changes in fair value of an Ownership Interest (except for a Portfolio Shareholding);
- b. profit or loss in respect of an Ownership Interest that is included in Financial Accounting Net Income or Loss under the equity method of accounting; and
- c. gains and losses from disposition of an Ownership Interest, except a Portfolio Shareholding.

Changes in fair value

49. The first type of Excluded Equity Gain or Loss is attributable to changes in fair value of an Ownership Interest that is accounted for using a fair value accounting method, including mark-to-market. A fair value method re-values the Ownership Interest periodically and changes in its value are reported as gain or loss, either in the profit and loss statement or in the OCI section of the balance sheet. Fair value method gains or losses on Ownership Interests other than Portfolio Shareholdings are excluded from the GloBE Income or Loss computation. Accordingly, excluded fair value gains require a negative adjustment and excluded fair value losses require a positive adjustment to the Financial Accounting Net Income or Loss. The fair value gain or loss for a Fiscal Year, however, must be adjusted to reflect any distributions on that Ownership Interest that were excluded from the computation of GloBE Income or Loss pursuant to Article 3.2.1(b). To the extent such fair value gains and losses are recorded in OCI or equity instead of the profit and loss statement, they may already have been excluded from the GloBE Income or Loss and no adjustment is necessary under Article 3.2.1(c).

Equity method accounting

50. The second type of Excluded Equity Gain or Loss is attributable to income or loss arising from an Ownership Interest accounted for using the equity method. Financial accounting standards typically require equity method accounting when the MNE Group holds a significant but non-Controlling Interest in an Entity, ordinarily between 20% and 50% of the equity interests in an Entity. These Entities are referred to as joint ventures or associates under financial accounting standards. As explained in the Commentary to Chapter 1, Entities that are joint ventures and associates for accounting purposes are not Constituent Entities under the definition in Article 1.3 because they are not controlled by the MNE Group. Under the equity method, the owner includes its proportionate share of the Entity's after-tax income or loss in the computation of its Financial Accounting Net Income or Loss.

51. The adjustment required in respect of Ownership Interests accounted for under the equity method may be a positive or negative amount depending upon whether the Entity reported net income or net loss. Equity method net income is a negative adjustment to the Financial Accounting Net Income or Loss. An equity method loss is a positive adjustment to the Financial Accounting Net Income or Loss. Equity method income or loss is excluded from the computation of GloBE Income or Loss irrespective of whether that income or loss, or a portion thereof, is included in the owner's taxable income computation under the laws of the jurisdiction in which the owner is located. Thus, if an Entity accounted for under the equity method is treated as a Tax Transparent Entity in the owner's tax jurisdiction, the annual income or loss is nevertheless removed from the owner's GloBE Income or Loss computation.

52. In general, entities whose Ownership Interests are accounted for under the equity method are not Constituent Entities. However, pursuant to Article 6.4, JVs as defined in Article 10.1 will be treated as if they were Constituent Entities. A JV subject to Article 6.4 is an Entity in which the UPE holds directly or indirectly at least 50% of its Ownership Interests. This definition encompasses Entities that are considered joint ventures for accounting purpose and some that are considered associates for accounting purposes.

The adjustment required by Article 3.2.1(c) also applies to Ownership Interests in JVs as defined in Article 10.1 because they too are accounted for using the equity method.

Gains or losses on disposition

53. The last type of Excluded Equity Gain or Loss are those gains and losses arising from a disposition of an Ownership Interest in any Entity where the MNE Group holds, in the aggregate, 10% or more of the Ownership Interests at the time of the transfer, i.e. Ownership Interests other than a Portfolio Shareholding. This category includes gains and losses from the sale of Ownership Interests in a Constituent Entity, JVs as defined in Article 10.1, as well as non-Portfolio Shareholdings in Entities that are not Constituent Entities or JVs. See Article 6.2.2 with respect to transfers of Ownership Interests that are treated as transfers of assets and liabilities of a Constituent Entity.

54. In many Inclusive Framework jurisdictions, gains arising from the disposition of Ownership Interests are wholly or partially exempt from tax or subject to taxation at reduced rates, and losses arising from the disposition of Ownership Interests may not be tax deductible. As with the taxation of dividends, there is significant variance in the way gain or loss from the disposal of an Ownership Interest is taxed under local law. Local tax treatment depends on the nature (and residence) of the issuer of the Ownership Interest and the way the sale transaction is structured. As discussed above, many Inclusive Framework jurisdictions fully or partially exempt from the tax base gains and losses arising from the disposition of Ownership Interests. Gain or loss arising on the disposition of an Ownership Interest, whether measured by reference to the carrying cost of the equity interest or the underlying assets, that is included in the financial accounting income of the seller but excluded from the seller's taxable income, would represent a permanent difference. If the difference is not adjusted for in the GloBE Income or Loss computation, gains on sales of Ownership Interests will result in a lower GloBE ETR for the seller (and potential tax liability under the GloBE Rules). Losses, on the other hand, will result in a higher GloBE ETR for the seller (and potentially shield other income from GloBE tax liability). The GloBE Rules eliminate most of these permanent differences by generally excluding gains and losses from dispositions of Ownership Interests from the seller's GloBE Income or Loss computation. However, gains and losses from the disposition of a Portfolio Shareholding are included in the GloBE Income or Loss.

55. The definition of Portfolio Shareholding is used both in the context of Excluded Dividends and in the context of Excluded Equity Gain or Loss (see above). In the context of Excluded Dividends, the potential scope of excluded income is broader than in the context of excluded gains, because the ownership period requirement limits the categories of dividends for which an exception to the exclusion is provided. In the context of Excluded Equity Gain or Loss, the following table summarises which gains and losses from the disposition of an Ownership Interest are includible in the GloBE Income or Loss of the Constituent Entity that disposed of that interest:

| Gains and losses arising from the disposition of | Portfolio Shareholding (i.e. carrying rights to less than 10% of the profits, capital, reserves or voting rights of the distributing entity) | Non-Portfolio Shareholding (i.e. carrying rights to at least 10% of the profits, capital, reserves and voting rights of the distributing entity) |
|---|--|--|
| Short-term shareholding (i.e. economically held for less than one year) | Included gain/loss | Excluded gain/loss |
| Non- Short-term shareholding (i.e. economically held for at least one year) | Included gain/loss | Excluded gain/loss |

56. Unlike the rule that applies for purposes of Excluded Dividends, the period during which the Portfolio Shareholding is held is not relevant for determining whether gains and losses arising from the disposition of that shareholding are includible in GloBE Income or Loss.

57. MNE Groups commonly hedge foreign currency movements in Ownership Interests in Constituent Entities. The GloBE Implementation Framework will consider providing Agreed Administrative Guidance on the extent to which such gains and losses may be treated as Excluded Equity Gains or Losses.

Paragraph (d) - Included Revaluation Method Gain or Loss

58. Under some financial accounting standards, an Entity can elect either the cost model or the revaluation model as its accounting policy for property, plant and equipment. Under the revaluation model, an asset is carried at a revalued amount, which is its fair value at the date of the revaluation less any subsequent accumulated depreciation and subsequent accumulated impairment losses. Revaluation increases are generally recognised in OCI, rather than profit or loss. Revaluation decreases, on the other hand, are generally (but not always) recognised in profit and loss. Absent a corrective measure the revaluation model would impact the computation of GloBE Income because revaluation gains are generally excluded from Financial Accounting Net Income or Loss and depreciation expense is determined based on the revalued amount. Therefore, to eliminate the effect of reporting gains or losses in OCI under the revaluation model on the computation of GloBE Income or Loss, paragraph (d) requires all Included Revaluation Method Gain or Loss for the Fiscal Year to be included in the computation of GloBE Income or Loss. Any revaluation losses or subsequent incremental increase in depreciation are allowed in the computation of GloBE Income or Loss to the extent they are attributable to revaluation increases (gains) included in the computation of GloBE Income or Loss pursuant to Article 3.2.1(d).

59. Article 10.1 defines Included Revaluation Method Gain or Loss as the net gain or loss, increased or decreased by any associated Covered Taxes, for the Fiscal Year in respect of all property, plant and equipment that arises under an accounting method or practice that:

- a. periodically adjusts the carrying value of such property to its fair value;
- b. records the changes in value in OCI; and
- c. does not subsequently report the gains or losses recorded in OCI through profit and loss.

60. The definition requires the amount of the gain or loss recorded in OCI to be increased by the amount of any associated Covered Taxes to the extent that gain or loss was recorded net of Covered Taxes. Any Covered Taxes (current or deferred) associated with Included Revaluation Method Gain or Loss are taken into account in the computation of Adjusted Covered Taxes under Article 4.1. The definition includes the amount of associated Covered Taxes to ensure that Covered Taxes are not both deducted (in effect) and taken into account in the ETR computation.

61. Revaluation gains and losses are brought in to income annually (or upon revaluation, if revaluations occur less frequently than annually) pursuant to Article 3.2.1(d). When gain is recognised on a period-by-period basis pursuant to paragraph (d), an adjustment will also need to be made to pick up taxes recognised in OCI each period, provided the gain is or will be taxable under local law. In some cases, a deferred tax expense can be recognised on revaluation gains in OCI when the gains are exempt from local tax because the deferred tax expense is calculated on the basis that the carrying amount of an item of Property, Plant & Equipment will be realised by using it to generate taxable profits rather than through sale. However, Covered Taxes should not be increased by deferred tax liabilities recognised where the sale of an asset will be exempt from local tax.

62. An election under Article 3.2.5 may be made with respect to tangible property that includes property subject to the revaluation model. If such an election is made, the gains or losses in the OCI would not be included in the computation of GloBE Income or Loss as they arise but would be deferred until the asset is disposed. That election also requires the Constituent Entity to determine its depreciation in respect of the assets subject to the election without regard to increases or decreases in the carrying value of the assets attributable to the revaluation model. And the Covered Taxes associated with the gains and losses in OCI would likewise need to be deferred until disposition of the asset.

Paragraph (e) - Gain or loss from disposition of assets and liabilities excluded under Article 6.3

63. Paragraph (e) requires an adjustment for gain or loss from disposition of assets and liabilities excluded under Article 6.3.

64. Gains and losses from the disposition of assets are generally taken into account under the GloBE Rules, even where the buyer is another Constituent Entity. Financial accounting rules typically include gains and losses from sales of assets. Assets acquired are recorded in the financial accounts at their cost. In the case of sales between members of the Group, however, adjustments to eliminate the intra-group gain or loss and the increase or decrease in the assets cost are made when the company prepares its consolidated financial accounts so that the intra-group transaction does not affect the Group's income on a consolidated basis. Nevertheless, each Constituent Entity's separate Financial Accounting Net Income or Loss should reflect the results of the transaction in the same manner as if it were a transaction with a non-Group member.

65. Article 6.3 generally requires inclusion of gain or loss arising from a transfer of assets (other than Ownership Interests that are not Portfolio Shareholdings) and liabilities in the computation of GloBE Income or Loss. Accordingly, a loss from a transfer of Ownership Interests in another Constituent Entity is not included under Article 6.3. As noted, this is the normal result of applying the financial accounting rules on a separate entity basis even for transfers between Constituent Entities. However, if the transfer is pursuant to a GloBE Reorganisation, the gain or loss (in respect of the transferred assets and liabilities) is included in the computation of GloBE Income or Loss only to the extent of Non-qualifying Gain or Loss, defined in Article 10.1 generally as the lesser of the taxable or financial accounting gain or loss on the transfer. In most cases, there will not be any Non-qualifying Loss because jurisdictions typically do not allow losses to be taken into account in connection with a tax-free reorganisation. To the extent gain is excluded under Article 6.3, a negative adjustment is required under Article 3.2.1(e), and to the extent a loss is excluded, a positive adjustment is required.

Paragraph (f) - Asymmetric Foreign Currency Gains or Losses

66. Paragraph (f) adjusts for Asymmetric Foreign Currency Gain or Loss. These are generally foreign currency exchange gains or losses (FXGL) that arise due to differences between the functional currency for accounting purposes and the one used for local tax purposes.

67. The GloBE Rules do not make any adjustments for FXGL when the functional currencies are the same. In those circumstances, any FXGL reflected in the financial accounts are included in the GloBE Income or Loss computation, irrespective of whether the local tax rules impose tax on FXGL. If FXGL is exempt under local tax rules, there will be a permanent difference that does, and should, affect the ETR of the jurisdiction.

68. The GloBE Rules do, however, make adjustments to avoid distortions that could arise when the functional currencies used for accounting and tax differ. The definition of Asymmetric Foreign Currency Gain or Loss in Article 10.1 includes four types of FXGL. The FXGL included in the definition are described based on the relationship between the tax functional currency, the accounting functional currency and a third foreign currency. The tax functional currency is the functional currency used to determine the Constituent Entity's taxable income or loss for a Covered Tax in the jurisdiction in which it is located. The accounting functional currency is the functional currency used to determine the Constituent Entity's Financial Accounting Net Income or Loss. A third foreign currency is a currency that is not the Constituent Entity's tax functional currency or accounting functional currency. The adjustments required under Article 3.2.2(f) with respect to each type of Asymmetric Foreign Currency Gain or Loss are explained below.

69. Paragraph (a) of the definition applies to transactions in the accounting functional currency that produce taxable gain or loss because the tax functional currency is different. It brings the tax FXGL into

the Financial Accounting Net Income or Loss. Paragraph (a) requires a positive adjustment to Financial Accounting Net Income or Loss in the amount of the tax foreign currency exchange (FX) gain and a negative adjustment to Financial Accounting Net Income or Loss in the amount of the tax FX loss.

70. Paragraph (a) also applies where an asset or liability denominated in the accounting functional currency is retranslated in the tax functional currency so that a tax FXGL arises, despite no FXGL arising for accounting purposes.

71. Paragraph (b) of the definition applies to transactions in the tax functional currency that produce an accounting gain or loss because the accounting functional currency is different. It removes the accounting FXGL from the Financial Accounting Net Income or Loss. Thus, paragraph (b) requires a negative adjustment to Financial Accounting Net Income or Loss in the amount of the accounting FX gain and a positive adjustment to Financial Accounting Net Income or Loss in the amount of the accounting FX Loss.

72. Paragraph (b) also applies where an asset or liability denominated in the tax functional currency is retranslated in the accounting functional currency so that an accounting FXGL arises, but no FXGL arises for tax purposes.

73. Paragraph (c) of the definition is the exclusionary arm of the rule in respect of FXGL arising from transactions in a third foreign currency. These transactions may result in an FXGL vis-à-vis both the accounting and tax functional currencies. However, paragraph (c) only applies to the FXGL in respect of the accounting functional currency. It excludes these gains and losses from the GloBE Income or Loss computation by requiring a negative adjustment to Financial Accounting Net Income or Loss in the amount of the accounting FX gain and a positive adjustment to Financial Accounting Net Income or Loss in the amount of the accounting FX Loss.

74. Paragraph (d) of the definition is the inclusionary arm of the rules for third foreign currency gains. It includes the gain or loss determined with respect to the tax functional currency by requiring a positive adjustment to Financial Accounting Net Income or Loss in the amount of the tax FX gain and a negative adjustment to Financial Accounting Net Income or Loss in the amount of the tax FX loss. This rule applies irrespective of whether the FXGL in the tax functional currency is includible in taxable income or subject to tax in the Constituent Entity's location. For purposes of paragraph (d), if the FX gain or loss is not subject to tax under local law, the tax FX gain or loss is the amount that would have arisen for tax purposes if the Constituent Entity had been subject to tax on the gain or loss using the same method for determining FXGL as is used in the financial accounts.

Paragraph (g) - Policy Disallowed Expenses

75. Paragraph (g) adjusts for Policy Disallowed Expenses which are defined in Article 10.1 to mean expenses accrued by the Constituent Entity for illegal payments, including bribes and kickbacks, and expenses accrued by the Constituent Entity for fines and penalties. There is a materiality threshold that prevents the rule from applying in the case of de minimis fines and because the rule only applies to fines and penalties that equal or exceed EUR 50 000 (or an equivalent amount in the functional currency in which the Constituent Entity's Financial Accounting Net Income or Loss was calculated). There is no such threshold for bribes and kickbacks which are always disallowed.

76. Bribes, kickbacks, and other illegal payments are allowed as expenses under financial accounting rules but are not deductible for tax purposes in most Inclusive Framework jurisdictions. For instance, tax deductions for bribes are disallowed for public policy reasons as part of the fight against corruption, and as reflected in the OECD Recommendation of the Council on Tax Measures for Further Combating Bribery of Foreign Public Officials in International Business Transactions (OECD, 2009^[3]).² For purposes of Article 3.2.1(g), a payment is illegal if it is illegal under the laws applicable to the Constituent Entity that made the payment or the laws applicable to the UPE.

77. Similar to bribes, fines and penalties imposed by a government are commonly disallowed for tax purposes. However, the policy rationale for denying a deduction for fines and penalties is to limit the economic cost to only the person that committed the act. This rationale would be diluted if the taxpayer were allowed to share the burden of the penalty with all taxpayers (by way of tax deduction for it).

78. However, fines and penalties, particularly those for minor offenses such as traffic tickets, are more frequent than bribes and vary widely in amount. For example, they can range from a EUR 50 traffic ticket incurred by a transportation company to a multi-million Euro fine for securities law violations incurred by a large bank. Recognising the de minimis nature of many fines and penalties, the GloBE Income or Loss prohibits deduction only for fines and penalties of EUR 50 000 (or equivalent currency) or more. The disallowance applies also to fines that may be levied in respect of the same activity on a periodic basis (e.g. daily fines) that in the aggregate equal or exceed EUR 50 000 (or equivalent currency) in a single year. A periodic fine or penalty includes a fine or penalty that is assessed periodically until corrective action is taken, but does not include separate fines that are for the same type of offense committed upon multiple occasions, such as traffic tickets. The purpose of the threshold is to continue to allow deductions for smaller fines that may not be specifically recorded as separate items in the accounts of the Constituent Entity. This approach avoids the complexity of tracking small fines and penalties for GloBE purposes while at the same time preventing MNEs from escaping a Top-up Tax because of a few large, non-deductible, fines or penalties. Interest charges for late payment of Tax or other liabilities to a governmental unit are not considered fines or penalties for this purpose, and do not need to be added back to Financial Accounting Net Income or Loss.

Paragraph (h) - Prior Period Errors and Changes in Accounting Principles

79. Paragraph (h) requires an adjustment for Prior Period Errors and Changes in Accounting Principles. Prior Period Errors and Changes in Accounting Principles are defined in Article 10.1 to mean changes in the opening equity, i.e. the equity at the beginning of the Fiscal Year, of a Constituent Entity attributable to a correction of a prior period error generally that affected the computation of GloBE Income or Loss in a previous Fiscal Year or a change in accounting principle or policy that affects income or expenses includible in the computation of GloBE Income or Loss. Paragraph (h) does not apply to an error correction that requires a corresponding decrease in Covered Taxes in a previous Fiscal Year of EUR 1 000 000 or more. Such error corrections are subject to the rules of Article 4.6.1.

80. When an MNE Group corrects an error in the computation of the Financial Accounting Net Income or Loss of a Constituent Entity for a prior Fiscal Year, it will need to re-determine the opening equity of the Entity in the Fiscal Year in which the error was discovered or as soon as practicable. In some cases, the MNE Group may be required to prepare restated Consolidated Financial Statements for the Fiscal Year to which the error relates. However, if the error is attributable to transactions between Group Entities and it resulted in equal offsetting errors in both Group Entities, the error may not have impacted the Consolidated Financial Statements. For purposes of the GloBE Rules, however, the adjustment to the opening equity of each Group Member must be taken into account pursuant to Article 3.2.1(h). The adjustments may increase or decrease the opening equity depending upon the nature of the error. For example, an erroneous exclusion of revenue will generally result in an increase to opening equity and a corresponding increase to income in the computation of the GloBE Income or Loss when the error is corrected.

81. To the extent that the error is attributable to a Fiscal Year prior to the application of the GloBE Rules to the Constituent Entity, the adjustment to opening equity does not result in an adjustment under Article 3.2.1(h) because it did not affect the computation of GloBE Income or Loss. Also, if the adjustment is a decrease that requires re-computation of the ETR and Top-up Tax for a previous Fiscal Year under Article 4.6.1, an adjustment under Article 3.2.1(h) is not required because the adjustment is made in the relevant Fiscal Year pursuant to Article 4.6.1.

82. When an MNE Group changes an accounting principle or policy used in the determination of its Financial Accounting Net Income or Loss it may be required to re-determine its opening equity as if it had used the new accounting principle or policy in previous Fiscal Years. This may be necessary to prevent the amount from being double-counted or omitted from the MNE Group's income or equity in a subsequent Fiscal Year as a result of the change in principle or policy. In the case of a change in accounting principle or policy, the increase or decrease in equity represents the net income, gain, expense, or loss that under the new accounting principle or policy will be included in the computation of Financial Accounting Net Income or Loss in a future period or that would have been included in that computation in a previous Fiscal Year. The change in accounting principle or policy may require either an increase or decrease in the opening equity. The adjustment under Article 3.2.1(h) should correspond directionally to the adjustment to opening equity. Thus, if a change in accounting principle or policy decreases opening equity, the adjustment under Article 3.2.1(h) would be a negative adjustment that has the same effect as an additional deduction in the computation of GloBE Income or Loss. Conversely, if a change in accounting principle or policy increases opening equity, the adjustment under Article 3.2.1(h) would be a positive adjustment that has the same effect as an additional income in the computation of GloBE Income or Loss.

83. To the extent the equity adjustment is attributable to items of income or expense that were, or would have been, included in the computation of GloBE Income or Loss, it must be treated as an increase or decrease to the Financial Accounting Net Income or Loss of the relevant Constituent Entity or Constituent Entities. To the extent that the adjustment relates to Fiscal Years prior to the application of the GloBE Rules to the Constituent Entity, it is excluded from the computation of GloBE Income or Loss.

84. The amount of the adjustment attributable to Fiscal Years prior to the application of the GloBE to the Constituent Entity should be determined based on all the facts and circumstances.

Paragraph (i) - Accrued Pension Expense

85. Pension liabilities are allowed as expenses in the computation of GloBE Income or Loss to the extent of contributions to a Pension Fund during the Fiscal Year. Calculating the annual expense for pension liabilities based on contributions to a Pension Fund has two benefits. First, the timing rule for deducting pension liabilities under local tax rules is commonly based on the timing of contributions; consequently, it will better align the timing of the expense from a GloBE Rules perspective with the effect on local tax liability attributable to the contribution. Second, it avoids complications and potential competitiveness concerns that would arise under some Acceptable Financial Accounting Standards that reflect some of the effects of pension accounting solely in the OCI.

86. The adjustment for Accrued Pension Expense required by Article 3.2.1(i) is equal to the difference between (a) the amount of pension contributions during the year and (b) the amount accrued as an expense in the computation of Financial Accounting Net Income or Loss during the Fiscal Year. The adjustment to Financial Accounting Net Income or Loss for this difference will be a positive amount if the amount accrued as an expense in the financial accounts exceeds the contributions for the year. It will be a negative amount in Fiscal Years in which the contributions exceed the expense accrued in the financial accounts. In the company pension schemes of some jurisdictions, the annual accrued pension expense is always equal to the annual contribution amount. In such cases, there would be no adjustment under Article 3.2.1(i).

Article 3.2.2

Stock-based Compensation

87. Article 3.2.2 provides an election to substitute in the computation of GloBE Income or Loss the amount of stock-based compensation allowed as a deduction in the computation of a Constituent Entity's taxable income in place of the amount expensed in its financial accounts. In many Inclusive Framework

jurisdictions, a corporation is entitled to deduct for tax purposes the value of stock-based compensation that it paid based on the market value of the stock when the option is exercised. For example, a corporation may be able to deduct the present value of the stock option at the time of issuance or over the exercise period and then the difference between the amount originally deducted and the market value when the option is exercised by the holder.

88. For financial accounting purposes, companies generally account for stock-based compensation based on the present value of the stock option at the time of issuance and amortise that amount over the exercise period. The company may adjust its estimate of the amount of the stock-based compensation expense and thus the amount taken as an accounting expense based on changes in circumstances during the exercise period. If the market value of the stock increases over the exercise period, the corporation will deduct an amount for tax purposes that is higher than the amount expensed for financial accounting purposes, which is a permanent difference.

89. This disparity between the amount of expense allowed in the computation of financial accounting income and the local tax base would often depress the GloBE ETR, in some cases below the Minimum Rate. The election under Article 3.2.2 brings the GloBE Income or Loss more into line with the local tax rules in those jurisdictions that allow a deduction based on the value of the stock at the exercise date. If the election is not made, the Constituent Entity simply computes its GloBE Income or Loss taking into account the amount of stock-based compensation allowed in the computation of its Financial Accounting Net Income or Loss.

90. The election must be made by the Filing Constituent Entity. The scope of the election is limited to compensation expenditures in the form of stock, stock options, stock warrants (or an equivalent) where the amount allowed as an expense is computed differently for local tax purposes than for financial accounting purposes. In principle, the election applies to stock-based compensation for employees and non-employees. However, if the local tax base applies different rules for employees and non-employees, the election will apply differently to stock-based compensation of employees and non-employees in conformity with those local tax rules.

91. If the election is made in respect of an option that expires without exercise, the Constituent Entity must treat the amount previously included as an expense in the computation of the GloBE Income or Loss pursuant to the election as additional income under the GloBE Rules. This rule prevents the Constituent Entity from retaining the benefit of a deduction for an item that will never be paid.

92. The election is a Five-Year Election and must be applied consistently to the stock-based compensation expense of all Constituent Entities located in the same jurisdiction and for the year in respect of which the election is made and all subsequent Fiscal Years, unless and until the election is revoked. The election is essentially made on a jurisdictional basis and thus can be made for some jurisdictions and not other jurisdictions. Further, revocation of the election is made on a jurisdictional basis.

93. If the election is made in a Fiscal Year after some of the stock-based compensation expense of a transaction has been recorded in the financial accounts but before the exercise date, the Constituent Entity must recapture the stock-based compensation expense allowed in the computation of its GloBE Income or Loss in previous Fiscal Years to the extent it exceeds the amount of the tax deduction that would have been allowed in respect of that compensation in previous Fiscal Years. Thus, a Constituent Entity cannot deduct the amount allowed for financial accounting purposes and then effectively deduct the same amount again based on the tax deduction. If an election under Article 3.2.2 is revoked before the end of the exercise period for some or all of the stock-based compensation paid by Constituent Entities located in the jurisdiction, those Constituent Entities must recapture the excess tax deductions taken in the computation of GloBE Income or Loss up to before the first year to which the revocation applies, but only with respect to stock-based compensation expenses for which an option has not yet been exercised. In other words, revocation of the election only affects stock-based compensation expense for which the final tax deduction

has not been determined; it does not affect the amount allowed as a deduction in respect of options that have already been exercised.

94. Regardless of whether an election under Article 3.2.2 is made, the entire amount of the stock-based compensation expense is subject to the condition that the item of expense must be susceptible to being reliably and consistently traced to the Constituent Entity that received the property, use of property, services, etc. for which the stock-based compensation was provided. The election only applies to the Constituent Entity that incurred the expense and received the property (including use of property) or services for which the stock-based compensation was provided. The stock provided does not need to be stock issued by the Constituent Entity that incurred the relevant expense. However, the expense for stock-based compensation is not allowed to the Constituent Entity that issued the shares used as compensation, unless it received the property, services, etc. for which the compensation was paid. Thus, for example, if a Constituent Entity provides stock-based compensation to its executives in the form of UPE stock, the Constituent Entity, not the UPE, deducts the value of the stock.

95. Only one Constituent Entity is allowed to deduct stock-based compensation in excess of the amount allowed in the financial accounts and only if that Constituent Entity is allowed a deduction for such stock-based compensation for local tax purposes. Thus, if the accounting expense needs to be moved from the Entity whose shares are used as the compensation to the Entity that incurred the expense, the expense of the Entity that issued the shares and the reimbursements from the Entity that incurred the expense should be in equal amounts based on the amount of the stock-based compensation expense allowed in the Consolidated Financial Statements.

Article 3.2.3

Arm's length requirement for cross-border transactions

96. Article 3.2.3 requires transactions between Group Entities to be priced consistently with the Arm's Length Principle and recorded at the same price for GloBE purposes for all Constituent Entities that are parties to the transaction.

97. Constituent Entities of an MNE Group typically maintain a transfer pricing policy based on the Arm's Length Principle and this standard is used to determine the transfer price that is reflected in their financial accounts and in computing the local taxable income. Therefore, it is generally expected that Constituent Entities' financial accounts will reflect transactions between Group Entities based on the Arm's Length Principle and at the same price. The MNE Group and the tax administrations examining the tax returns of Constituent Entities engaged in the controlled transactions are in the best place to assess compliance with the Arm's Length Principle. Where the MNE Group has used the transfer price reflected in its financial accounts to compute local taxable income and the relevant tax authorities do not require a transfer pricing adjustment, this price should be used in the computation of GloBE Income or Loss. In these circumstances, the MNE Group should not make an adjustment under Article 3.2.3.

98. Article 3.2.3 requires an adjustment to the Financial Accounting Net Income or Loss to avoid double taxation or double non-taxation under the GloBE Rules where the taxable income of one or more Constituent Entities that are parties to a controlled transaction (counterparties) is determined using a transfer price different from the one used in the financial accounts. These differences may arise in the local tax return as filed or later when the tax return is audited by the local tax authority of one or more counterparties.

99. Where all of the relevant tax authorities agree that a transfer price must be adjusted to the same price in order to reflect the Arm's Length Principle, the counterparties shall adjust their GloBE Income or Loss based on that price for purposes of computing GloBE Income or Loss. For example, such an instance would arise where a bilateral Advance Pricing Agreement (APA) is agreed by the competent authorities of

all counterparty jurisdictions concerned. The adjustments to the GloBE Income or Loss must be applied consistently for GloBE purposes across all counterparties in line with the arm's length price agreed under the bilateral Advance Pricing Agreement. If, in connection with an audit of counterparties' tax returns, the relevant tax authorities agree that a transfer price must be adjusted to the same price, each Constituent Entity concerned must adjust its GloBE Income or Loss. The adjustment to each counterparty's transfer price is taken into account in the computation of its GloBE Income or Loss pursuant to Article 4.6.1.

100. In some cases, the transfer price used in the financial accounts of the counterparties may differ from the transfer price used to compute a counterparty's taxable income but not the transfer price used to compute another counterparty's taxable income in another jurisdiction. These differences may arise where:

- a. a unilateral APA has been agreed;
- b. a Constituent Entity files a tax return under a self-assessment system that includes book-to-tax adjustments, in order to comply with domestic transfer pricing rules; or
- c. a tax authority challenges and adjusts the transfer price used in the local tax return of one of the Constituent Entities.

101. When these differences arise, the transfer price used for taxable income purposes is presumed to be consistent with the Arm's Length Principle. The GloBE Income or Loss should be adjusted accordingly under Article 3.2.3 where necessary to prevent double taxation or double non-taxation under the GloBE Rules. Specifically, a unilateral transfer pricing adjustment will result in a corresponding adjustment to the GloBE Income or Loss of all counterparties under Article 3.2.3, unless the transfer pricing adjustment increases or decreases the MNE Group's taxable income in a jurisdiction that has a nominal tax rate below the Minimum Rate or that was a Low-Tax Jurisdiction with respect to the MNE Group in each of the two Fiscal Years preceding the unilateral transfer pricing adjustment (an under-taxed jurisdiction).³

102. This rule results in adjustments where necessary to prevent double taxation or double non-taxation. For example, a local transfer pricing adjustment that increases the taxable income in a high-tax jurisdiction results in a corresponding adjustment under Article 3.2.3 where that adjustment is necessary to ensure a corresponding decrease to the GloBE Income of the relevant counterparties in an under-taxed jurisdiction. Without this adjustment, the income included in the high-tax jurisdiction under local law would be subject to double taxation – once in the high-tax jurisdiction and again under the GloBE Rules. Similarly, if an adjustment decreases the taxable income in a high-tax jurisdiction, corresponding adjustments to the GloBE Income or Loss of all counterparties will ensure that the GloBE Income of counterparties in under-taxed jurisdictions is increased by a corresponding amount and exposed to Top-up Tax under the GloBE Rules. Without this adjustment, the income excluded from the high-tax jurisdiction taxable income would benefit from double non-taxation, in that it would not be subject to tax in the high-tax jurisdiction or under the GloBE Rules. GloBE Rules

103. However, adjustments will not be made under this rule when such adjustments would give rise to double taxation or double non-taxation under the GloBE Rules. For example, a unilateral transfer pricing adjustment that reduces taxable income in a jurisdiction that has a nominal tax rate above the Minimum Rate but that had an ETR below the Minimum Rate in the previous two years should not be reflected in the GloBE Income or Loss, because if the counterparties are located in a high-tax jurisdiction, such adjustment would produce double non-taxation under the GloBE Rules (i.e. the adjusted income is not subject to tax in either jurisdiction and is not exposed to Top-up Tax under the GloBE Rules). Finally, a unilateral transfer pricing adjustment that increases taxable income in an under-taxed jurisdiction should not be reflected in the GloBE Income because such adjustment would produce double taxation under the GloBE Rules (i.e. the adjustment would expose the income to Top-up Tax in the jurisdiction in which the unilateral adjustment is made and the income is already subject to local tax in the other jurisdiction and/or Top-up Tax if the other jurisdiction is an under-taxed jurisdiction).

104. Article 3.2.3 does not impose any requirements beyond an arm's length price. Thus, it does not require the MNE Group to conform the timing of an item of income or expense for GloBE purposes to the timing of that item for local tax purposes.

105. The GloBE Implementation Framework will give further consideration to the appropriate adjustments to the GloBE Income in situations where, in connection with a proceeding concerning the tax returns of two or more counterparties, the relevant tax authorities disagree as to whether or to what extent a transfer price needs to be adjusted to reflect the Arm's Length Principle as well as in other situations where adjustments are necessary to avoid double taxation or double non-taxation under the GloBE Rules. In addition, the GloBE Implementation framework will consider information reporting related to adjustments made by Constituent Entities pursuant to Article 3.2.3.

Arm's length requirement for same-country transactions

106. Transactions between Constituent Entities located in the same jurisdiction, on the other hand, generally are not required to be adjusted, for tax purposes, from the amounts used in preparation of the Consolidated Financial Statements. This is because the shifting of income from one taxpayer to another within the same jurisdiction will generally not impact on the overall amount of income subject to tax in that jurisdiction. These same-country transactions may already be eliminated or otherwise adjusted for local tax purposes pursuant to a consolidation or group tax relief regime. For GloBE purposes, additional adjustments to conform with the Arm's Length Principle in respect of wholly domestic transactions should not generally be required because the effect of these transactions will generally be eliminated under the jurisdictional blending rules of Chapter 5. Furthermore, the Constituent Entities may not be applying the Arm's Length Principle to same-jurisdiction transactions in a jurisdiction that does not impose a Covered Tax.

107. However, Article 3.2.3 does require the application of the Arm's Length Principle to transactions between Constituent Entities in the same jurisdiction if the sale or other transfer of an asset produces a loss and that loss is taken into account in the computation of GloBE Income or Loss. This rule is intended to prevent MNE Group's from manufacturing losses in a jurisdiction through sales or other transfers between Group members at prices that are not consistent with the Arm's Length Principle. The rule does not apply if the loss is excluded from the Constituent Entity's GloBE Income or Loss computation. Thus, if the MNE Group has in place an election under Article 3.2.8 to apply consolidated accounting in the jurisdiction in which the loss arises, the loss will be eliminated in consolidation and excluded from the computation of the Constituent Entity's GloBE Income or Loss.

108. Transactions between Minority-Owned Constituent Entities and other Constituent Entities must also be recorded in accordance with the Arm's Length Principle. This is necessary because Minority-Owned Constituent Entities are not included in the ETR and Top-up Tax computations for the jurisdiction under Articles 5.1 and 5.2, but instead compute their ETR and Top-up Tax separately pursuant to Article 5.6. Thus, the income and expense of the parties to the transaction will not be eliminated in the jurisdictional blending computation and failure to reflect transactions based on the Arm's Length Principle would distort the ETR and Top-up Tax calculations for the jurisdiction and the Minority-Owned Constituent Entities. Similarly, transactions between Investment Entities and other Constituent Entities located in the same jurisdiction must also be recorded in accordance with the Arm's Length Principle.

109. Finally, although not explicitly stated in Article 3.2.3, transactions between Constituent Entities in the same jurisdiction must also be recorded in the same amount in both Constituent Entities. This is the expected result from applying a common accounting standard to Constituent Entities in the same jurisdiction. The principle applies, however, in all cases to prevent the exclusion of income from, or duplication of expenses in, the GloBE Income or Loss computation.

Article 3.2.4

Qualified Refundable Tax Credits

110. Article 3.2.4 prescribes the treatment of certain refundable tax credits. The refundable tax credits referred to in Article 3.2.4 are government incentives delivered via the tax system. They are not ordinary refunds of tax paid in a prior period due to an error in the computation of tax liability or pursuant to an imputation system. Instead, they are incentives to engage in certain activities, such as research and development, whereby the government allows the company to offset its taxes dollar-for-dollar for engaging in specified activities or incurring specified expenditures or the government will refund the amount of the unused credit if the company doesn't have any tax liability. In this way, the government effectively pays for the activity or expenditure in a similar manner to a grant. The basic idea is that the incentive or grant is delivered by a tax reduction to the extent possible because it is more efficient than having checks from the government and taxpayer crossing in the mail.

111. The full amount of a Qualified Refundable Tax Credit will be treated as GloBE Income of the recipient Constituent Entity in the year such entitlement accrues. This reflects that these types of refundable tax credits share features of, and should be treated in the same way as, government grants that form part of income, given that they are in effect government support for a certain type of activity that can ultimately be received in cash or cash equivalent. See also the Commentary on the definition of Qualified Refundable Tax Credit.

112. In cases where an amount of a Qualified Refundable Tax Credit has been recorded as a reduction in current income tax expense (or other Covered Taxes) in the financial accounts of the Constituent Entity, that amount must be treated as an Addition to Covered Taxes under Article 4.1.2(d) to fully reverse the accounting entry that treated it as a tax reduction instead of income. This ensures that the Qualified Refundable Tax Credit is treated as an item of income rather than a reduction of accrued taxes. No adjustment is required if a tax credit that meets the definition of Qualified Refundable Tax Credit was already treated as income in the financial accounts.

113. Likewise, a tax credit that does not meet the conditions for being a Qualified Refundable Tax Credit, i.e. a Non-Qualified Refundable Tax Credit, but that was treated as income in the financial accounts, must be deducted in full from the measure of net income in the financial statements, and there must be a corresponding reduction of Adjusted Covered Taxes under Article 4.1.3(b).

114. Where the tax credit regime under the laws of a jurisdiction provides for partial refundability, such that only a fixed percentage or portion of the credit is refundable, these rules apply separately to the refundable part and the non-refundable part of the tax credit.

Article 3.2.5

Election to use realisation method in lieu of fair value accounting

115. Article 3.2.5 provides an election to use the realisation method for assets and liabilities that are accounted for in the Constituent Entity's financial accounts using the fair value method or impairment accounting. The election generally applies with respect to all assets and liabilities of all Constituent Entities in a jurisdiction and may be made with respect to those assets or liabilities after the year in which the asset was acquired. However, the election can be limited to tangible assets of such Constituent Entities or to assets and liabilities of such Constituent Entities that are Investment Entities.

116. Under the election, gain or loss associated with an asset or liability will arise when the asset is disposed rather than as its value changes due to changes in market value or impairments. The carrying value of such asset or liability for purposes of determining gain or loss shall be the carrying value of that asset or liability at the later of the time the asset was acquired or liability was incurred or the beginning of

the year for which the election is made. Accordingly, under Article 3.2.5, a Constituent Entity must exclude fair value or impairment gain or loss in respect of assets or liabilities subject to the election from the computation of GloBE Income or Loss and must include gain or loss determined under the realisation method.

117. The policy justification for this treatment is to reduce volatility by allowing the taxpayer to crystallise the gain for GloBE purposes as of the actual date of disposition rather than from one period to the next in line with the accounting treatment. For example, if a Constituent Entity holds convertible debt in a start-up company and the company performs poorly in its first few years, the Constituent Entity may be required, under the applicable accounting standard, to recognise a fair value loss on the investment. If the start-up is eventually acquired by an unrelated purchaser and the Constituent Entity disposes of the convertible debt for its original acquisition cost, the “gain” reported upon sale is not really an economic gain but could be subject to a Top-up Tax if there are no related Covered Taxes paid in respect of the gain in that year. An election under Article 3.2.5 prevents this result by permitting the Constituent Entity to determine the gain upon sale based on the original cost of the asset.

118. An election under Article 3.2.5 is a Five-Year Election. It cannot be revoked within five Fiscal Years after an Election Year and another election cannot be made within five Fiscal Years after a revocation year. In the year an election under this Article is revoked, the GloBE Income or Loss is adjusted by the difference between the fair value of the asset or liability at the beginning of the year and the carrying value of the asset or liability determined pursuant to the election. This adjustment recaptures the net fair value gain or loss that arose during the pendency of the Article 3.2.5 election.

Article 3.2.6

Election to spread capital gains over five years

119. Article 3.2.6 provides an election that permits an MNE Group to spread the effect of gains and losses from the sale of Local Tangible Assets over a period of up to five years to mitigate the effect of recognising the entire gain in a single year on the MNE Group’s jurisdictional ETR computation and to match the timing of gains and losses on Local Tangible Assets. The policy justification for this election is that the increase in value of the asset likely accumulated over a period of years and spreading the gain over that period, up to a maximum of five years, and matching it with losses from similar property provides a better measure of whether the MNE Group has been subject to a minimum level of tax in the jurisdiction over that period.

120. The election is an Annual Election made on a jurisdictional basis. It applies only with respect to gains and losses attributable to disposition of Local Tangible Assets, defined in Article 10.1 as immovable property located in the same jurisdiction as the Constituent Entity. This limitation ensures that relief provided under this section cannot be used to shelter gain on mobile assets. However, the election may be combined with an election under Article 3.2.5 in respect of tangible assets. In that case, fair value gains or losses and impairment adjustments associated with the asset during the pendency of the Article 3.2.5 election will have been excluded from the computation of GloBE Income or Loss and the carrying value for determining gain or loss will not be adjusted for fair value changes or impairments. The election does not apply to sales between Group Entities because the spread period includes all years in which Constituent Entities held the property.

121. Under the election, the Aggregate Asset Gain in the year for which the election is made (the Election Year) is allocated to the years in the Look-back Period (defined in Article 10.1 as the Election Year and the four prior Fiscal Years). The Aggregate Asset Gain is the net gain in the Election Year from the disposition of Local Tangible Assets by all Constituent Entities located in the jurisdiction except for gain or loss on a transfer of assets between Group Members.

122. The Aggregate Asset Gain is not simply prorated over the Look-back Period. Instead, it is first matched against Net Asset Losses arising during the Look-back Period (that haven't already been offset under a previous Article 3.2.6 election), starting with the earliest Loss Year (defined in Article 10.1 as a Fiscal Year in the Look-back Period for which there is a Net Asset Loss for a Constituent Entity located in that jurisdiction and the total amount of Net Asset Loss of all such Constituent Entities exceeds the total amount of their Net Asset Gain) in the period. If the Aggregate Asset Gain is not fully absorbed in the earliest Loss Year, the balance is brought forward to the next Loss Year, and so on, until the Aggregate Asset Gain is fully absorbed or there are no remaining Loss Years in the Look-back Period.

123. Net Asset Loss in respect of a Constituent Entity and a Fiscal Year, is defined in Article 10.1 as the net loss from the disposition of Local Tangible Assets by that Constituent Entity in that year excluding the gain or loss on a transfer of assets to another Group Member. The amount of Net Asset Loss for each Fiscal Year in the Look-back Period is reduced by the amount of Net Asset Gain or Adjusted Asset Gain that is set-off against it pursuant to the application of Article 3.2.6(b) or (c) as a result of a previous Article 3.2.6 election. In other words, when an Aggregate Asset Gain is set-off against a Net Asset Loss of a Fiscal Year pursuant to an election under Article 3.2.6, that Net Asset Loss is reduced by a corresponding amount for purposes of a subsequent election under Article 3.2.6. This prevents that amount from being used again in the future to eliminate another Aggregate Asset Gain from the computation of GloBE Income or Loss. Where the Net Asset Losses of all Constituent Entities in the jurisdiction for a Fiscal year exceed the Aggregate Asset Gain brought to the Fiscal Year, the Aggregate Asset Gain is set-off against the Net Asset Loss of each Constituent Entity based on the ratio of the Constituent Entity's Net Asset Loss to the total Net Asset Losses of all Constituent Entity's in the jurisdiction for the Fiscal Year.

124. If there is an amount of Aggregate Asset Gain in excess of the Net Asset Losses in the Loss Years of the Look-back Period, that excess is spread evenly (i.e. pro-rated) over the Look-back Period and then allocated among Constituent Entities based on their respective Net Asset Gains in the Election Year. Net Asset Gain is defined in Article 10.1 as the net gain from the disposition of Local Tangible Assets by a Constituent Entity located in the jurisdiction for which the election was made excluding the gain or loss on a transfer of assets to another Group Member. Finally, the Effective Tax Rate and Top-up Tax, if any, for each previous Fiscal Year in the Look-back Period must be re-calculated under Article 5.4.1.

125. When the election is made, any Covered Taxes (including deferred tax assets) with respect to any Net Asset Gain or Net Asset Loss in the Election Year must be determined based on the facts and circumstances and excluded from the computation of Adjusted Covered Taxes. In many cases when the election is made, it is being made because there are no Covered Taxes attributable to Net Asset Gains or Net Asset Loss on Local Tangible Assets. To the extent the election is not made and there are Covered Taxes attributable to Net Asset Gains or Net Asset Loss on Local Tangible Assets, such Covered Taxes remain in the ETR computation. Determining the amount of Covered Taxes to apportion to each year would be unduly cumbersome and the allowance of a carry-back tailored to match losses in prior years is a substantial benefit. Therefore, the Covered Taxes arising in the Election Year, if any, with respect to Net Asset Gains or Losses are excluded from Adjusted Covered Taxes.⁴

126. Note that to the extent a GloBE Loss was generated in previous Fiscal Years, such GloBE Loss must be recalculated after the application of this Article. To the extent a GloBE Loss is reduced as a result of the operation of this Article and such loss had been used in a Fiscal Year, the Top-up Tax for such Fiscal Year must also be re-computed in line with the principles of Articles 4.6 and 5.4.

Article 3.2.7

Special Rule for Intragroup Financing Arrangements

127. Article 3.2.7 provides a rule with respect to Intragroup Financing Arrangements that increase the amount of expenses taken into account in computing the GloBE Income or Loss of a Low-Tax Entity and

do not result in a corresponding increase to the taxable income of the High-Tax Counterparty to such arrangement. This rule prevents MNE Groups from engaging in transactions that are intended to increase the ETR in a jurisdiction that is below the Minimum Rate by reducing the GloBE Income or Loss in such jurisdiction without increasing the taxable income of the counterparty to the arrangement. A payment should not be treated as increasing the taxable income of a High-Tax Counterparty if it is eligible for an exclusion, exemption, deduction or credit or other tax benefit under local law and the amount of that benefit is calculated by reference to the amount of payment received. For example, assume that Jurisdiction A has introduced an interest limitation rule that limits a taxpayer's net interest deduction to a percentage of its earnings. The amount of interest expense denied under this interest limitation rule constitutes excess interest capacity that is eligible to be carried forward and set-off against interest income in a subsequent year. For example, a High-Tax Counterparty located in Jurisdiction A lends money to a Low-Tax Entity. At the time the loan is entered into, the High-Tax Counterparty has excess interest capacity from previous years that is not expected to be used over the expected term of the loan. In this case, the receipt of interest from the Low-Tax Entity under the loan will not be treated as giving rise to an increase in taxable income to the extent the High-Tax Counterparty can immediately set-off such interest income against the carry-forward of excess interest capacity.

128. An Intragroup Financing Arrangement is defined in Article 10.1 as any arrangement entered into between two or more members of the MNE Group whereby a High-Tax Counterparty directly or indirectly provides credit or otherwise makes an investment in a Low-Tax Entity. The term arrangement includes an agreement, plan or understanding (whether enforceable or not) and includes all the steps and transactions that give effect to that arrangement. Whether there is an arrangement in place is an objective test to be inferred from the actual transactions that took place and the information available to those involved in the arrangement. A series of transactions will be treated as part of an Intragroup Financing Arrangement where an objective observer would reasonably conclude that they were part of a plan or arrangement to allow a High-Tax Counterparty to provide credit or make a direct or indirect investment in a Low-Tax Entity. The test is an objective one, based on an assessment of the actual transactions that took place in light of the overall outcomes achieved. A step or transaction can form part of an arrangement even though the details may not be known to all the parties to the arrangement.

129. For example, a member of the MNE Group may act as an intermediary by borrowing money from a High-Tax Counterparty and then on-lending it to a Low-Tax Entity within the same group. In this case, the back-to-back loans could be considered part of an arrangement whereby a High-Tax Counterparty has indirectly provided credit to a Low-Tax Entity. Although the High-Tax Counterparty did not know the ultimate destination of the funds, it would be sufficient that the intermediary borrowed the funds with the specific purpose of on-lending them to the Low Tax Entity. If the Intermediary operates, however, as a treasury or financing centre for the group that manages the group's working capital requirements, the money borrowed from the High-Tax Counterparty may, on an objective assessment, be considered entirely separate from and independent of the loan made to the Low-Tax Entity such that these loans are not considered part of an Intragroup Financing Arrangement.

130. Article 3.2.7 only applies when the arrangement can reasonably be expected, over the duration of the arrangement, to reduce the GloBE income of a Low-Tax Entity without increasing the taxable income of the High-Tax Counterparty. The duration of, and expected outcomes under, the arrangement should be determined based on an objective assessment, including by taking into account the financing requirements of the parties. Even if the initial loan is only made for a limited duration, a financing arrangement may reasonably be expected to be in place for an extended period if it is put in place to finance a long-term investment.

131. A Low-Tax Entity is defined in Article 10.1 as a Constituent Entity located in a Low-Tax Jurisdiction or a jurisdiction that would be a Low-Tax Jurisdiction if the ETR for the jurisdiction were determined without regard to any income or expense accrued by that Entity in respect of an Intragroup Financing Arrangement.

A Low-Tax Jurisdiction, in respect of an MNE Group in any Fiscal Year, is a jurisdiction where the MNE Group has Net GloBE Income and is subject to an ETR in that period that is lower than the Minimum Rate.

132. A High-Tax Counterparty is defined in Article 10.1 as a Constituent Entity that is located in a jurisdiction that is not a Low-Tax Jurisdiction or that is located in a jurisdiction that would not be a Low-Tax Jurisdiction if its ETR were determined without regard to any income or expense accrued by that Entity in respect of an Intragroup Financing Arrangement.⁵

Article 3.2.8

Election to consolidate transactions in same jurisdiction

133. Article 3.2.8 provides an election that permits consolidated accounting treatment to be applied to transactions between Constituent Entities of the same MNE Group located in the same jurisdiction. If this election is made, income, expenses, gains and losses resulting from transactions between the Constituent Entities may be eliminated from the computation of GloBE Income or Loss in the same manner as amounts relating to transactions among members of a consolidated group are eliminated as part of the consolidation adjustments under the Acceptable Financial Accounting Standard used by the UPE in preparing its Consolidated Financial Statements. This is intended to prevent unintended consequences where income, expense, gains and losses from domestic intra-group transactions are treated as tax neutral intra-group transactions under local law. The consolidated accounting should not eliminate the MNE Group's economic income from transactions with third parties nor should it result in the carrying value of any assets being adjusted to include purchase accounting adjustments held in consolidation. Assets will continue to be held at their original carrying values and the full economic gain or loss accruing during the MNE Group's ownership of those assets should be brought into account when they are sold outside of the tax consolidated group or outside of that jurisdiction. The requirement that the Constituent Entities are included in a tax consolidated group includes any rules of the local jurisdiction which enable the Constituent Entities to share current income or losses by virtue of the fact that they are related through ownership or common control.

134. Many transactions between Constituent Entities result in immediate income for the seller and an immediate expense for the buyer and would net to zero in the computation of Net GloBE Income for the jurisdiction. For example, interest would be an expense for the borrowing Constituent Entity and income for the lending Constituent Entity and would accrue at the same time for both Constituent Entities under the same financial accounting standard. However, some transactions would essentially shift income, gain, expense or loss to the other member of the group to be recognized in a subsequent Fiscal Year in connection with a third-party transaction. For example, inventory sold from a purchasing Constituent Entity to a manufacturing Constituent Entity may be manufactured into a finished product and sold to a third-party customer in the following Fiscal Year. The MNE Group's consolidated accounting should take into account the full gain from the sale to a third party.

135. The election is limited to transactions between Constituent Entities (other than Investment Entities, Minority-Owned Constituent Entities, and JVs treated as Constituent Entities under Article 6.4) located in the same jurisdiction. Transactions between Constituent Entities located in different jurisdictions would continue to be treated in the same manner as transactions with a third party and would not benefit from the netting or income deferral that results from the election. Building on the inventory example above, if the manufacturing Constituent Entity instead sells its finished product to a resale Constituent Entity located in another jurisdiction, the manufacturing Constituent Entity would be required to recognize the MNE Group's profit on that intra-group sale (taking into account the Arm's Length Principle) as if it were a sale to a third-party customer.

136. Thus, the election requires the MNE Group to distinguish between transactions between Constituent Entities in the same jurisdiction and Constituent Entities in different jurisdictions which creates

some compliance burden. However, transactions between the Constituent Entities in the same jurisdiction may already be eliminated or deferred for local tax purposes pursuant to the applicable consolidation or group tax relief regime. In addition, the Constituent Entities may not be applying an arm's length standard to same-jurisdiction transactions in a jurisdiction that does not impose a Covered Tax. In these cases, the MNE Group may prefer the election over the burden of determining arm's length prices for transactions between Constituent Entities in the same jurisdiction.

137. When an election pursuant to Article 3.2.8 is made or revoked, appropriate adjustments will be required to ensure that there is no duplication or omission of items of GloBE Income or Loss.

Article 3.2.9

Exclusion of certain insurance company income

138. Article 3.2.9 excludes certain income of an insurance company from the computation of GloBE Income. Insurance companies are sometimes subject to current tax on returns that must be contractually paid over to policyholders. The insurance company passes that tax along to the policyholders through a charge so that the company is in effect reimbursed for taxes paid, in some sense, on behalf of the policyholder. It is normally the case that the insurance company passes that tax along to the policyholders through a charge, specifically by way of a reduction in policy liabilities equivalent to the tax. The reduction is recognised as income and so the company is in effect reimbursed for taxes paid on behalf of the policyholder.

139. Financial accounting standards generally treat the returns that will be contractually paid over to the policyholder as income of the insurance company and the corresponding liability to pay the returns over to the policyholder as an expense resulting in a net zero effect on its income before tax. The tax paid on behalf of policyholders, as stated above, reduces policy liabilities resulting in a profit before tax for the insurance company. If the tax paid on the policyholder's return is treated as an above-the-line expense of the insurance company, these two items also will result in a net zero effect on the company's profit before tax and have no effect on the GloBE ETR.

140. However, the tax paid on the policyholder returns may be treated as an income tax under some financial accounting standards. Thus, even though the reduction in the policyholder liability and the tax on investment income are equal and offsetting in the end, the former increases pre-tax income above-the-line and the latter is treated as a below-the-line tax expense under some financial accounting standards. Thus, for GloBE purposes, the tax is included in the Covered Taxes that increase the numerator of the ETR fraction and the charge (reduction in policy liabilities equivalent to the tax) is income included in the GloBE Income that increases the denominator of the ETR fraction. Consequently, instead of offsetting the reduction in the policyholder liability with no effect on the ETR computation, the tax would effectively provide shelter from Top-up Tax to other low-taxed income earned by the insurance company.

141. To address this issue, the charge of tax (or reduction in policyholder liabilities equivalent to policyholder tax) is excluded from the computation of GloBE Income or Loss under Article 3.2.9 and any taxes arising on the policyholder returns are excluded from the definition of Covered Taxes pursuant to Article 4.2.2(e). However, amounts charged to policyholders for taxes paid by the insurance company in respect of returns to the policyholders, are only to be excluded from the GloBE Income and Loss calculation if that tax is not included as an expense within the profit or loss before tax in the financial accounts. If the tax on the policyholder returns is treated as an above-the-line expense under the accounting standard used in the Consolidated Financial Statements, it will offset the charge of tax (or reduction in policyholder liabilities equivalent to policyholder tax) and thus no adjustment is necessary.

Article 3.2.10*Additional Tier One Capital*

142. Article 3.2.10 provides a special rule for the treatment of Additional Tier One Capital, which is defined in Article 10.1 as an instrument issued by a Constituent Entity pursuant to prudential regulatory requirements applicable to the banking sector that is convertible to equity or written down if a pre-specified trigger event occurs and that has other features which are designed to aid loss absorbency in the event of a financial crisis. This type of capital is commonly referred to in financial markets as Additional Tier One Capital.

143. Additional Tier One Capital is generally treated as equity for financial accounting purposes. However, it is treated as debt for tax purposes in some Inclusive Framework jurisdictions. Thus, for many Constituent Entities, payments in respect of Additional Tier One Capital are deductible as interest expense by the issuer and includible as interest income of the holder for tax purposes. This represents a permanent difference between financial accounting and taxable income that is both common and material. Accordingly, Article 3.2.10 provides that increases or decreases to the equity of a Constituent Entity attributable to distributions in respect of Additional Tier One Capital shall be treated as income or expense in the computation of its GloBE Income or Loss. Equity adjustments attributable to the issuance or redemption of Additional Tier One Capital are not included in the computation of GloBE Income or Loss.

144. Article 3.2.7 does not apply to deny a deduction for distributions treated as an expense pursuant to Article 3.2.10.

Article 3.2.11

145. Article 3.2.11 requires adjustments to a Constituent Entity's Financial Accounting Net Income or Loss where necessary to reflect the requirements of Chapters 6 and 7. For example, if a Constituent Entity is required to use the historical carrying value of an asset pursuant to Article 6.2 and it used the fair value of that asset to compute its depreciation expense for the Fiscal Year, it must adjust the depreciation expense to the amount that would have been computed using the historical carrying value of the asset.

Article 3.3 - International shipping income exclusion

146. Article 3.3 provides an exclusion for income derived from international shipping. The international shipping industry has long been subject to industry-specific tax rules. The capital intensive nature, the level of profitability and long economic life cycle of international shipping has led a number of jurisdictions to introduce alternative or supplementary taxation regimes for this industry. The tax regimes applicable to international shipping, such as tonnage taxes, may result in less volatile tax outcomes for shipping and provide a more stable basis for long term investment. The widespread availability of these alternative tax regimes means that international shipping often operates outside the scope of corporate income tax. Including international shipping within the scope of the GloBE Rules would therefore raise policy questions in light of the policy choices of these jurisdictions.

147. Article 3.3 adopts a qualified income approach based on the scope of Article 8 of the OECD Model Tax Convention (OECD, 2017^[1]) and excludes from the scope of the GloBE Rules the profits from transportation of passengers or cargo by ships in international traffic. Like the adjustments in Article 3.2, the exclusion for International Shipping Income and Qualified Ancillary International Shipping Income is an adjustment to the Financial Accounting Net Income or Loss. The exclusions are computed on a net basis pursuant to Article 3.3.2 to Article 3.3.5. The adjustment will be a negative amount in the situation where the International Shipping Income or Qualified Ancillary International Shipping Income is positive. The

adjustment will be a positive amount in the situation where the International Shipping Income or Qualified Ancillary International Shipping Income is negative.

148. To the extent an adjustment required by Article 3.3 excludes an amount of income from the GloBE Income or Loss computation, any Covered Taxes associated with that income must also be excluded from Adjusted Covered Taxes pursuant to Article 4.1.3(a).

Article 3.3.1

149. As set out in Article 3.3.1, the income from the computation of a Constituent Entity's International Shipping Income and Qualified Ancillary International Shipping Income shall be excluded from the computation of its GloBE Income or Loss, under the conditions provided in Article 3.3.

150. Any losses from the computation of a Constituent Entity's International Shipping Income or Qualified Ancillary International Shipping Income shall also be excluded from the computation of a Constituent Entity's GloBE Income or Loss for the jurisdiction in which that Constituent Entity is located.⁶

Article 3.3.2

151. Article 3.3.2 defines International Shipping Income as the net income obtained by the Constituent Entity from the activities specified in paragraphs (a) to (f), except to the extent the net income is obtained from the transportation of passengers or cargo by ships via inland waterways within the same jurisdiction.

152. The primary exclusion is set out in paragraph (a). This paragraph excludes the profits or net income obtained by a Constituent Entity from the transportation of passengers or cargo by ships in international traffic in line with Article 8(1) of the OECD Model Tax Convention. For the purposes of the GloBE Rules, the term "international traffic" means any transport by a ship, except when the ship is operated solely between places within a single jurisdiction (regardless of whether such jurisdiction is the same jurisdiction as the one in which the Constituent Entity is located). This differs slightly from the definition in Article 3 of the OECD Model, which adds the qualification "and the enterprise that operates the ship or aircraft is not an enterprise of that State". While these words are necessary for the proper operation of Article 8 of the OECD Model Tax Convention, the transport by a ship, when the ship is operated solely between places in a jurisdiction and the Constituent Entity that operates the ship is located in that jurisdiction, would also not be considered as international traffic for purposes of the GloBE Rules (OECD, 2017^[1]).

153. Consistent with paragraph 4 of the Commentary on Article 8 of the OECD Model Tax Convention, this exclusion applies whether a ship is owned, leased or otherwise at the disposal of the Constituent Entity. For example, the exclusion would include income from the transportation by a ship in international traffic where the Constituent Entity is the lessee of a ship under a bare boat-chartering-in arrangement. The exclusion does not apply to the profits from towing or dredging activities but it would apply to the profits from transportation of passengers or cargo in international traffic by offshore service vessels.

154. Paragraphs (b) to (e) make explicit the statements in the Commentary on Article 8 of the OECD Model Tax Convention that the category of profits that fall within Article 8(1) in respect of the operation of a ship also benefit from this exclusion.

155. Paragraph (b) provides that, consistent with paragraph 6 of the Commentary on Article 8 of the OECD Model Tax Convention, the exclusion also applies in respect of the transportation of passengers or cargo by ships operated in international traffic under slot-chartering arrangements. As explained in the example in paragraph 6 of the Commentary on Article 8 of the OECD Model Tax Convention, the net income derived by a Constituent Entity from the transportation of passengers or cargo otherwise than by ships that it operates is covered when that enterprise has some of its passengers or cargo transported under slot-chartering arrangements.

156. Paragraph (c) provides that, consistent with paragraph 5 of the Commentary on Article 8 of the OECD Model Tax Convention, the exclusion also applies to net income obtained by a Constituent Entity from leasing out a ship on charter fully equipped, crewed and supplied, for example a time or voyage charter under which a vessel and crew are hired for a voyage from a load port to a discharge port, provided the ship is to be used for the transportation of passengers or cargo in international traffic. To benefit from the exclusion, the lessor needs to demonstrate that the ship is expected to be used for the transportation of passengers or cargo in international traffic.

157. Paragraph (d) covers intragroup leasing of ships on a bare boat charter basis, for the use of transportation of passengers or cargo in international traffic, where the Constituent Entity is the lessor and leases out a ship to another shipping enterprise that is a Constituent Entity on charter without crew or master. This income is covered under Paragraph 5 of the Commentary on Article 8 of the OECD Model Tax Convention only if the leasing (whether or not intragroup) is an ancillary activity of an enterprise engaged in the international operation of ships. The leasing of ships on a bare boat charter basis is considered as international shipping income (instead of ancillary) for purposes of the GloBE Rules as an exception, under the condition that the lessee is also a Constituent Entity of the same MNE Group and has International Shipping income. Including this item of income ensures that the structure of intragroup transactions involving Constituent Entities of the same MNE Group does not affect the characterisation of International Shipping Income.

158. Paragraph (e) provides that the exclusion also applies to net income obtained by a Constituent Entity from the participation in a pool, a joint business or an international operating agency for the transportation of passengers or cargo by ships in international traffic, which falls under Article 8(2) of the OECD Model Tax Convention.

159. Paragraph (f) provides that the exclusion for international shipping also applies to capital gains (or losses) on the sale of qualifying ships used for the transportation of passengers or cargo in international traffic, which would normally fall under Article 13 of the OECD Model Tax Convention. A minimum holding period requirement of 1 year is applied for the purposes of the GloBE Rules to prevent ship trading activities from qualifying for the exclusion. Ships that have been purchased with a view to reselling are usually recorded as inventory in the financial accounts under IAS 2, and gains (or losses) on the sale of such ships when the holding period is not met do not qualify for the exclusion. Legally owned ships used for international shipping operations are recognized as Property, Plant & Equipment assets in the financial accounts under IAS 16 if they are held for use in the production or supply of goods or services, for rental to others, or for administrative purposes, and are expected to be used during more than one period (IFRS Foundation, 2022^[2]). Capital gains (or losses) on the sale of such ships recognized as Property, Plant & Equipment assets in the financial accounts would qualify for the exclusion provided that they have been recorded as being held for use in the financial accounts of the Constituent Entity for 1 year or more.

160. Finally, the last sentence of Article 3.3.2 provides that the exclusion does not apply to net income obtained by a Constituent Entity from the transportation of passengers or cargo by ships via inland waterways within the same jurisdiction, such as rivers, canals and lakes.

Article 3.3.3

161. Article 3.3.1 excludes not only International Shipping Income from the computation of GloBE Income or Loss but also Qualified Ancillary International Shipping Income. This means that the exclusion for international shipping also applies to net income from certain ancillary activities.

162. Article 3.3.3 defines Qualified Ancillary International Shipping Income. The ancillary activities identified in this Article are limited to those explicitly mentioned in the Commentary on Article 8 of the OECD Model Tax Convention (OECD, 2017^[11]). To qualify for the exclusion, the income must be obtained

by a Constituent Entity from the activities listed in Article 3.3.3 that are performed primarily in connection with the transportation of passengers or cargo by ships in international traffic.

Leasing on a bare boat charter basis limited to 3 years

163. Paragraph (a) of Article 3.3.3 covers leasing arrangements on a bare boat charter basis (as mentioned in paragraph 5 of the Commentary on Article 8 of the OECD Model Tax Convention) where a Constituent Entity leases out a ship as an ancillary activity to another shipping enterprise that is not a Constituent Entity on charter without crew or master (i.e. where the Constituent Entity is the lessor and the vessel is operated by another party, the charterer). For this purpose, a shipping enterprise is an enterprise that operates ships. See above the Commentary on paragraph (d) of Article 3.3.2 where the lessee is a Constituent Entity.

164. Paragraph 5 of the Commentary on Article 8 of the OECD Model Tax Convention provides that Article 7, and not Article 8, applies to profits from leasing a ship on a bare boat charter basis except when it is an ancillary activity of an enterprise engaged in the international operation of ships. The Commentary on Article 8 of the OECD Model Tax Convention does not provide for a time limit for that activity to be considered as ancillary. The three year time-limit condition in Article 3.3.3(a) is intended to limit the eligibility of this exclusion to income from bare-boat chartering-out by a shipping company with short-term over-capacity, and to prevent the exclusion being applied to income from long-term leasing arrangements. However, the three-year time limit is not intended to encompass what would be considered an ancillary bare boat charter as referred to in paragraph 5 of the Commentary on Article 8 of the OECD Model Tax Convention. The three year time-limit condition would not be met when the contractual arrangement provides that the bare boat is available to the lessee for a time period that exceeds three years. For that purpose, other bare boat charters of the same ship, concluded with respect to prior or subsequent periods, would need to be taken into account. If a contractual arrangement is agreed for a shorter period than three years, the facts and circumstances would be analysed to determine whether the total period of the charter has exceeded three years. For instance, the renewal of a two-year bare boat charter for another period of two years would be considered as exceeding three years. Therefore, income earned after the date of the renewal would not qualify for the exclusion. Whether the income earned before the date of the renewal would qualify for the exclusion would depend on the facts and circumstances.

Ticket sales for domestic part of international voyage

165. Paragraph (b) of Article 3.3.3 covers the income obtained by a Constituent Entity from the sale of tickets issued by other shipping enterprises for the domestic leg of an international voyage (as mentioned in paragraph 8 of the Commentary on Article 8 of the OECD Model Tax Convention). For this purpose, a shipping enterprise is an enterprise that operates ships.

Container leasing

166. Paragraph (c) of Article 3.3.3 covers the income obtained by a Constituent Entity from the leasing and short-term storage of containers, for example where the enterprise charges a customer for keeping a loaded container in a warehouse pending delivery, or from detention charges for the late return of containers (as mentioned in paragraph 9 of the Commentary on Article 8 of the OECD Model Tax Convention). For instance, a period of 5 days or less could be presumed to be short-term for this purpose. Facts and circumstances would, however, need to be taken into account to determine whether the storage was short-term.

Engineering maintenance and other services

167. Paragraph (d) of Article 3.3.3 covers the income obtained by a Constituent Entity from the provision of services to other shipping enterprises by engineers, maintenance staff, cargo handlers, catering staff, and customer services personnel (as mentioned in paragraph 10 of the Commentary on Article 8 of the OECD Model Tax Convention). As mentioned above, a shipping enterprise is an enterprise that operates ships.

Ancillary investment income

168. Paragraph (e) of Article 3.3.3 covers investment income where the investment that generates the income is made as an integral part of carrying on the business of operating the ships in international traffic (as mentioned in paragraph 14 of the Commentary on Article 8 of the OECD Model Tax Convention). This would apply to interest income generated, for example, from cash deposits or other short-term working capital necessary for the carrying on of that business. This would also apply to interest income on bonds posted as security where this is required by law in order to carry on the business; in such cases, the investment is needed to allow the operation of the ships at that location.

169. Enterprises engaged in the operation of ships in international traffic may also be required to acquire and use emissions permits and credits. Income derived by such enterprises with respect to such permits and credits where such income is an integral part of carrying on the business of operating ships in international traffic would also be treated as Qualified Ancillary Income, for example, where permits are acquired for the purpose of operating ships or where permits acquired for that purpose are subsequently traded when it is determined that they will not be needed.

170. Paragraph (e) does not apply, however, to interest income derived in the course of the handling of cash-flow or other treasury activities for other Constituent Entities regardless of whether such Constituent Entities are located within or outside that jurisdiction (centralisation of treasury and investment activities). Nor would it apply to interest income generated by the short-term investment of the profits generated by a shipping operation where the funds invested are not required for that operation.

Treatment of inland transportation

171. Under specific circumstances, inland transportation could be considered as ancillary to an international shipping income for purposes of the OECD Model Tax Convention (see paragraph 7 of the Commentary on Article 8 of the OECD Model Tax Convention). Inland transportation is, however, not covered as a qualified ancillary activity under Article 3.3.3 for the purposes of the international shipping income exclusion. Excluding income from inland transportation from the scope of Qualified Ancillary International Shipping Income mitigates the risk of competitive distortions, which could otherwise arise from including such transportation as a qualified ancillary activity under the GloBE Rules, between shipping companies that have vertically integrated such services as part of their international shipping operation and independent freight forwarding and land-based logistics service providers.

Article 3.3.4

172. Article 3.3.4 provides a limitation on the amount of ancillary income that qualifies for the exclusion. The rationale for the limitation is that ancillary activities should only qualify for the exclusion where they are providing necessary support to the primary activity of the international shipping operation.

173. The Qualified Ancillary Shipping Income for the jurisdiction that exceeds 50% of International Shipping Income does not qualify for the exclusion; the excess is included in the GloBE Income. The limitation applies on a jurisdictional basis. The Qualified Ancillary Shipping Income for the jurisdiction is the lesser of the total net income from qualified ancillary activities of all Constituent Entities located in the

jurisdiction or half of the total International Shipping Income of such Constituent Entities. Applying the limitation thus requires that the net income of a Constituent Entity from its international shipping activities under Article 3.3.2 be computed separately from its net income from qualified ancillary activities under Article 3.3.3. The Qualified Ancillary Shipping Income for the jurisdiction in excess of the limitation must be allocated among Constituent Entities in the jurisdiction in proportion to the Qualified Ancillary Shipping Income of each of those Constituent Entities.

Article 3.3.5

174. Article 3.3.5 relates to the deduction and allocation of costs related to International Shipping Income and Qualified Ancillary International Shipping Income. Costs directly incurred by a Constituent Entity from the operation of an international shipping business should be allocated on a facts and circumstances basis to compute the net income of a Constituent Entity from its international shipping activities. Such directly attributable costs include items such as but not limited to:

- The costs of operating the vessel:
 - Employee costs (e.g. ship crew and management);
 - Bunker (fuel) expense;
 - Maintenance and upgrades (dry-docking);
 - Terminal, stevedoring and port expenses;
- The costs related to the use of the vessel:
 - Depreciation expense for ships and other maritime equipment and infrastructure;
 - Ship charter expenses;
 - Leasing of shipping containers, cargo handling.

175. The list of costs provided above is provided for illustration purposes and does not affect the characterisation of the income generated by the Constituent Entity related to these cost items as International Shipping Income or Qualified Ancillary International Shipping Income.

176. Indirect costs (i.e. all costs that are not direct costs) should be allocated between a Constituent Entity's international shipping income and other income on a formulaic basis in proportion to its revenues from international shipping over its total revenues. For example, assume a Constituent Entity accrues 80 of revenue from international shipping activities, 20 of revenue from qualified ancillary activities and 20 of revenue from non-qualified activities and incurs 30 of indirect costs for the Fiscal Year. The Constituent Entity should allocate 20 ($= 30 \times [80 / 120]$) of indirect costs to international shipping activities, 5 ($= 30 \times [20 / 120]$) to qualified ancillary activities and 5 ($= 30 \times [20 / 120]$) to non-qualified activities.

177. International Shipping Income and Qualified Ancillary International Shipping Income are net income or loss amounts under Article 3.3.2 and Article 3.3.3 and are excluded from the computation of a Constituent Entity's GloBE Income or Loss for purposes of Article 3.2, as provided under Article 3.3.1. Pursuant to Article 3.3.5, all direct and indirect costs attributed to a Constituent Entity's International Shipping Income and Qualified Ancillary International Shipping Income that are deducted in the computation of such excluded income cannot be deducted in the computation of its GloBE Income or Loss. Read together, these provisions require a single adjustment to the Financial Accounting Net Income or Loss equal to the net income or net loss that is excluded from the GloBE Income or Loss computation. In other words, by separately computing the International Shipping Income and Qualified Ancillary International Shipping Income and then removing that net amount from the GloBE Income or Loss computation, the Constituent Entity already meets the requirements of Article 3.3.5 notwithstanding that the gross revenues and expenses from shipping activities were included in the computation of the Financial Accounting Net Income or Loss. For example, if a Constituent Entity receives 1,000 in fees for the transportation of cargo in international traffic and incurs 700 of costs in connection with those fees, its

Financial Accounting Net Income or Loss would be 300 and its International Shipping Income would be 300. The Constituent Entity is not required to adjust the expenses taken into account in computing its Financial Accounting Net Income or Loss, but instead subtracts the amount of its International Shipping Income (300) from the Financial Accounting Net Income or Loss (300) to arrive at the GloBE Income ($300 - 300 = 0$).

178. To the extent that direct or indirect costs are attributable to income from qualified ancillary activities in excess of the 50% limitation under Article 3.3.4, those costs are taken into account in the computation of a Constituent Entity's GloBE Income or Loss because the related income is included in the computation as well.

179. For example, assume a Constituent Entity engaged in international shipping has 200 of revenue from international shipping activities and 130 of direct and indirect costs related thereto, and thus 70 of International Shipping Income and 100 of revenue from qualified ancillary activities and 60 of direct and indirect costs related thereto and thus 40 of Qualified Ancillary International Shipping Income. The net income from Qualified Ancillary International Shipping Income exceeds 50% of the International Shipping Income by 5 ($= 40 - [70 \times 50\%]$) and therefore is not excluded from the computation of GloBE Income or Loss. The Constituent Entity reduces its Financial Accounting Net Income or Loss of 110 ($= 300$ revenues – 190 expenses) by (i) the International Shipping Income of 70 and (ii) the allowable Qualified Ancillary International Shipping Income of 35, for the purposes of computing its GloBE Income.

Article 3.3.6

180. Article 3.3.6 imposes a substance criterion in order to qualify for the exclusion. Article 3.3.6 is aimed at ensuring that the strategic or commercial management of all ships deployed in earning International Shipping Income is effectively carried on from within the jurisdiction where the Constituent Entity is located. This condition is consistent with how many shipping tax regimes are designed in order to establish an economic link between the shipping company and the jurisdiction of the shipping tax regime.

181. The strategic or commercial management of the ships concerned is limited to those deployed in earning International Shipping Income and must be effectively carried out in the jurisdiction where the Constituent Entity is located in order to qualify for the exclusion. For this purpose, the ships deployed in earning International Shipping income are those that are engaged in the transportation of passengers or cargo in international traffic, whether owned, leased or otherwise at the disposal of the Constituent Entity.

182. Whether the strategic or commercial management is effectively carried on from within the jurisdiction where the Constituent Entity is located should be determined on the basis of the relevant facts and circumstances, and taking into account all relevant factors depending on the item of income. The relevant factors take into account not only the strategic or commercial management activities of the ships concerned that are conducted inside the jurisdiction but also the strategic or commercial management activities of the ships concerned that are conducted outside the jurisdiction. The mere fact that a vessel is flagged in a particular jurisdiction is not a relevant factor in the determination of whether strategic or commercial management is effectively carried on from within that jurisdiction. However, as discussed below, the requirements imposed by a flag jurisdiction may be relevant to such determination in respect of the jurisdiction where the requisite activities are performed.

183. Strategic management includes making decisions on significant capital expenditure and asset disposals (e.g. purchase and sale of ships), award of major contracts, agreements on strategic alliances and vessel pooling, and the direction of foreign establishments. Relevant factors that demonstrate strategic management include location of decision-makers, including senior management staff, location of company board meetings, location of operational board meetings and residence of directors and key employees.

184. Commercial management includes route planning, taking bookings for cargo or passengers, insurance, financing, personnel management, provisioning and training. Relevant factors that demonstrate

commercial management include the number of employees engaged in these activities in the jurisdiction, the nature and extent of the accommodation occupied in the jurisdiction, and the country of residence of key management staff, including company directors.

185. Under some shipping tax regimes, a management requirement is often applied in conjunction with a flag link, which means that ships and their owners have to abide by the conditions of the flag jurisdiction's shipping register. Generally, the flag jurisdiction is responsible for making sure that ships flying their flag abide by the international conventions of the International Maritime Organisation and the International Labour Organisation that the flag jurisdiction has ratified, including maritime safety, pollution and other environmental impacts, as well as working conditions. Depending on these requirements a flag link may entail specific duties on the Constituent Entity to ensure that flagged vessels abide by such requirements. Where these responsibilities are imposed on and managed by a Constituent Entity, this may result in that Constituent Entity having a sufficient level of strategic management that is effectively carried on from within the jurisdiction where it is located. Similarly, where these responsibilities are imposed on and managed by another Constituent Entity located in the same jurisdiction as the Constituent Entity that derives International Shipping Income or Qualified Ancillary International Shipping Income, this may result in the Constituent Entity having a sufficient level of strategic management that is effectively carried on from within the jurisdiction where the Constituent Entity is located.

Article 3.4 - Allocation of Income or Loss between a Main Entity and a Permanent Establishment

186. A PE is a tax rather than an accounting concept. This means that financial accounting information may not always be separately maintained in respect of the PE. In many cases, however, separate accounts may be maintained either for management purposes or to comply with local tax rules. Given that the GloBE Rules primarily rely on accounting information rather than management accounts or local tax information, Article 3.4 ensures that the right amount of Financial Accounting Net Income or Loss is allocated between the PE and Main Entity.

187. In making this allocation, the accounting treatment is followed as far as possible. This is subject, however, to the income and expense allocation rules under a Tax Treaty or domestic tax law.

Article 3.4.1

188. Article 3.4.1 refers to cases where a PE exists for purposes of the GloBE Rules by virtue of paragraphs (a), (b), and (c) of the definition included in Article 10.1. These paragraphs refer to cases where a PE exists in accordance with a Tax Treaty or domestic law, and in cases where it would have existed if a jurisdiction without a CIT had a Tax Treaty with the jurisdiction of the Main Entity.

189. In these situations, the first sentence of Article 3.4.1 provides that Financial Accounting Net Income or Loss of the PE is the net income or loss reflected in its financial accounts (if they exist). This ensures that Constituent Entities that are PEs and subsidiaries are treated in the same way for the purposes of computing the ETR. However, following the principle in the GloBE Rules, such accounts have to be prepared in accordance with an Acceptable Financial Accounting Standard or an Authorised Financial Accounting Standard subject to adjustments to prevent any Material Competitive Distortions.

190. However, in some cases the PE will not have separate financial accounts. In that scenario, the second sentence of Article 3.4.1 provides that the Financial Accounting Net Income or Loss is the amount that would have been reflected in its separate financial accounts if they existed. Therefore accounts or reports will need to be prepared in such a scenario to compute the amount that would have been reflected in the financial accounts. Article 3.4.1 requires this determination to be based on the accounting standard used in preparation of the Consolidated Financial Statements of the UPE.

Article 3.4.2

191. Article 3.4.2 adjusts the amount and items of income and expenses that can be attributed to the PE for the purposes of determining its Financial Accounting Net Income or Loss under Article 3.4.1. Given that a PE is a tax concept, there are no specific accounting rules for determining which items and amounts of income and expenses are taken into account by the Main Entity or the PE for purposes of determining the Financial Accounting Net Income or Loss.

192. Article 3.4.2(a) provides that the amount and items of income and expenses are those being attributed to the PE in accordance with the Tax Treaty or domestic law of the source jurisdiction. The phrase “regardless of the amount of income subject to tax and the amount of deductible expenses in that jurisdiction” is intended to distinguish between the tax rules for attributing income to the PE and the tax rules, including timing rules, for computing its taxable income.

193. For example, A Co is a Constituent Entity of the MNE Group located in Country A that has a PE in Country B in accordance with the A-B Tax Treaty. Assume that 100 of business profits are attributable to the PE which are derived from royalties payments (assume there are no deductible expenses). Country B exempts 50% of the royalties. In this case, the amount of income considered for purpose of determining the financial accounting net income of the PE is 100, notwithstanding that the PE is taxed only with respect to 50.

194. If the PE in Country B had separate financial accounts that reflected a greater amount because it also includes other items of income that were not attributable to the PE under tax rules, then such items would not be taken into account in accordance with the first sentence of Article 3.4.2.

195. On the other hand, if the PE in Country B had separate financial accounts that reflected a greater or lesser amount of income or expense because of a difference between the timing rules for that income under local tax rules (e.g. due to accelerated depreciation for tax purposes in Country B), the amount of income reported in the financial accounts for each relevant Fiscal Year would be used to determine the income attributable to the PE, rather than the amount of income calculated under the tax rules.

196. Article 3.4.2(b) provides that where a PE exists in accordance with paragraph (c) of the definition in Article 10.1, then the income or expenses for determining the Financial Accounting Net Income or Loss would be the amounts and items that would have been attributed in accordance with Article 7 of the OECD Model Tax Convention. This sentence accounts for the scenario in paragraph (c) of the definition of PE, which is based on activities in a jurisdiction that would hypothetically create a PE under Article 5 of the OECD Model Tax Convention (OECD, 2017^[11]).

Article 3.4.3

197. Article 3.4.3 describes the attribution of income to a PE that arises under paragraph (d) of the PE definition in Article 10.1. Article 3.4.3 attributes to the PE the income that the Main Entity jurisdiction exempts from tax and that is attributable to activities occurring outside the jurisdiction. Similarly, Article 3.4.3 allocates to the PE any expenses that are not taken into account in the jurisdiction of the Main Entity because they are attributable to activities occurring outside the jurisdiction.

Article 3.4.4

198. Article 3.4.4 provides that the Financial Accounting Net Income or Loss of a PE as adjusted by Articles 3.4.2 and 3.4.3 should not be taken into account in determining the GloBE Income or Loss of the Main Entity. Thus, if the Financial Accounting Net Income or Loss of a PE is reflected in the financial accounts of a Main Entity, it must be subtracted from the Financial Accounting Net Income or Loss of the Main Entity. This Article is intended to prevent double counting or omission of Financial Accounting Net Income or Loss in the computation of the GloBE Income or Loss of the Main Entity and the PE.

Article 3.4.5

199. Article 3.4.5 provides a rule relating to the allocation of losses of a PE. Some jurisdictions include the income or loss of a PE in the computation of the domestic taxable income of its Main Entity (e.g., jurisdictions with a worldwide tax system with a foreign tax credit system). However, GloBE Rules calculate the ETR of the Main Entity without taking into account the GloBE Income or Loss of the PE. Absent a special rule, the ETR of the Main Entity may be understated in a Fiscal Year when a PE loss is taken into account for domestic tax purposes but not for GloBE Income or Loss purposes. Under Article 3.4.5 this domestic treatment can be preserved, with the necessary corresponding adjustments.

200. A GloBE Loss of a PE shall be treated as an expense of the Main Entity for purposes of computing its GloBE Income or Loss, to the extent that the loss of the PE is treated as an expense in the computation of the domestic taxable income or loss of such Main Entity. This provision applies irrespective of whether the tax base of the Main Entity takes into account the net loss of the PE or each of its items of income and expense. Thus, if the Main Entity takes into account only 80% of a PE loss in computing its domestic taxable income, then the same percentage of the PE's GloBE Loss is treated as an expense in the computation of the Main Entity's GloBE Income or Loss and the remaining 20% is treated as a loss in computing the PE's GloBE Income or Loss. However, if a PE loss produces a time-limited loss carry-forward for the Main Entity it is treated as an expense in the computation of the Main Entity's domestic taxable loss irrespective of whether such carry-forward expires before it is used in full.

201. The last part of the first sentence requires a PE loss not to be set off against an item of income that is subject to tax under the laws of both the jurisdiction of the Main Entity and the jurisdiction of the Permanent Establishment. The limitation on the loss reattribution to the Main Entity is illustrated by the following example.

202. A Main Entity (ME1) has a PE (PE1) and another Main Entity (ME2) has another PE (PE2). Both Main Entities are located in jurisdiction A and both PEs are located jurisdiction B. Jurisdiction A has a worldwide tax system that taxes foreign PE income and provides a foreign tax credit for taxes paid on such income. Both jurisdictions allow sharing of income and losses among tax residents and PEs located in their jurisdiction if they are under common control (e.g., tax consolidation regime). PE1 has a tax loss of 100 and PE2 has taxable net income of 100. In both jurisdictions, the tax loss of PE1 is set off against the taxable net income of PE2 so that there is no tax to pay in either jurisdiction with respect to PE1 and PE2. While the loss of PE1 is treated as an expense of ME1 in jurisdiction A, it is not reallocated to jurisdiction A under Article 3.4.5 on the basis that it is set off against an item of income that is subject to tax under the laws of both jurisdiction A and jurisdiction B. In this scenario, it is unnecessary to allocate the loss of PE1 to ME1 and jurisdiction A since its ETR is not being understated due to such loss, and the allocation of the loss to jurisdiction A would in fact understate the ETR of jurisdiction B.

203. The second sentence of Article 3.4.5 requires a corresponding adjustment which treats GloBE income subsequently earned by the PE as GloBE Income of the Main Entity (and not of the PE) up to the amount of the GloBE Loss that previously was treated as an expense for purposes of computing the GloBE Income or Loss of the Main Entity. This rule applies to the full extent of the amount of loss treated as an expense in the computation of the Main Entity's domestic taxable income or loss. Thus, even if the loss became part of a loss carry-forward in the Main Entity's jurisdiction that expired before it was used in full, the PE's income to the extent of that loss is treated as GloBE Income of the Main Entity. This rule avoids difficult tracing issues and complex rules that would be needed to administer a tracing rule.

Article 3.5 - Allocation of Income or Loss from a Flow-through Entity

204. Article 3.5 determines how the GloBE Income or Loss of a Flow-through Entity is allocated between different Constituent Entities. These rules are necessary because in many cases, these Entities would

have their separate financial accounts showing their Financial Accounting Net Income or Loss regardless of the fact that they have no taxable net income or loss because it has been allocated to its owners under the tax rules. Given that the GloBE Rules rely on the accounting information, Article 3.5 ensures the right allocation of Financial Accounting Net Income or Loss between these Entities and its owners in accordance with the applicable tax rules.

205. In general, a Flow-through Entity is an Entity that is fiscally transparent in the jurisdiction where it is created. Flow-through Entities can be divided into two categories: Tax Transparent Entities and Reverse Hybrid Entities. A Flow-through Entity is treated as a Tax Transparent Entity if the direct owners of the Entity treat it as fiscally transparent. A Flow-through Entity is treated as a Reverse Hybrid Entity if the direct owners treat the Entity as opaque or not fiscally transparent. The Commentary on Article 10.2 contain a more detailed explanation on how these terms operate.

206. The general mechanics of Article 3.5 are as follows. First, the Financial Accounting Net Income or Loss of the Flow-through Entity has to be reduced by the amount attributable to the owners that are not members of the MNE Group. This ensures that the jurisdictional ETR of the members of the MNE Group is properly computed given that taxes paid by non-members of the MNE Group are not taken into account for purposes of the ETR computation.

207. Second, if the Financial Accounting Net Income or Loss of a PE is included in the Financial Accounting Net Income or Loss of a Flow-through Entity because the business of the latter is carried out through the former, then such amount has to be subtracted from the Flow-through Entity's Financial Accounting Net Income or Loss. This ensures that the Financial Accounting Net Income or Loss of the PE is not taken into account twice in the ETR computations.

208. Third, the remaining amount of the Financial Accounting Net Income or Loss of the Flow-through Entity is allocated as follows:

- a. If the Flow-through Entity is a Tax Transparent Entity (other than the UPE), then it is allocated to its Constituent Entity owners;
- b. If the Flow-through Entity is a Reverse Hybrid, then it is allocated to the Entity; or
- c. If the Flow-through Entity is a Tax Transparent Entity and the UPE of the MNE Group, then it is allocated to the UPE. Article 7.1 would then apply with respect to the UPE's GloBE Income or Loss.

Article 3.5.1

209. Article 3.5.1 allocates the Financial Accounting Net Income or Loss of a Flow-through Entity among PEs, Constituent Entity-owners and the Entity itself. It applies after a reduction is made (if any) with respect to the Ownership Interests held by minorities (e.g., non-Group Entities) in accordance with Article 3.5.3. Article 3.5.1 first allocates the Financial Accounting Net Income or Loss of a Flow-through Entity to a PE and then allocates the remaining amount to the Entity or its Constituent Entity-owners depending on characteristics of the Entity. These rules are contained in Article 3.5.1, as follows.

Income first allocated to a PE

210. Paragraph (a) provides that if the business of the Flow-through Entity is partially or totally carried out through a PE, the Financial Accounting Net Income or Loss of the Flow-through Entity is attributed to that PE in accordance with Article 3.4. This rule ensures that the Financial Accounting Net Income or Loss of the PE is removed from the Financial Accounting Net Income or Loss of the Flow-through Entity where it is included.

211. The PE could be situated in the jurisdiction where the Entity was created or in a third jurisdiction. For example, A Co is a company located in Country A and a partner of B LP, which is a Tax Transparent Entity organised in accordance with the laws of Country B. Under Country B's tax law, A Co has a PE in Country B because the business activities of B LP are being carried out through an office therein. Since B LP is fiscally transparent in Country B, Country B considers, for tax purposes, that A Co is carrying out business activities directly through the office, which creates the PE. In this case, B LP is the Main Entity of the PE located in Country B and therefore, the Financial Accounting Net Income or Loss of B LP has been reduced from the Financial Accounting Net Income or Loss of the Main Entity and attributed to the PE.

212. In other cases, the PE can be located in a third jurisdiction. Consider the previous example but instead of having an office in Country B, B LP has its office in Country C which creates a PE in this jurisdiction (Country C). This scenario is also covered by paragraph (a) of Article 3.5.1. It is irrelevant whether the third jurisdiction requires A Co or B LP to pay the tax with respect to the income attributable to the PE. The phrase "through which the business of the Entity is wholly or partly carried out" ensures that Article 3.5.1(a) applies regardless of whether the third jurisdiction sees the Entity as a Flow-through Entity and whether such jurisdiction requires the Entity or its Constituent Entity-owners to pay the tax with respect to the income attributable to the PE. If the Constituent Entity-owner of the Flow-through Entity is required to pay a Covered Tax with respect to the income attributable to the PE, such tax is allocated pursuant to Article 4.3.2(a).

Residual allocated to direct owners

213. Article 3.5.1(b) allocates the Financial Accounting Net Income or Loss of a Tax Transparent Entity that is not the UPE of the MNE Group. In this case, such income or loss is allocated to the Constituent Entity-owners in accordance with their Ownership Interests in the profits of that Entity to reflect the tax treatment in both the Entity's and owner's jurisdictions.

214. If the Constituent Entity-owners are also Tax Transparent Entities, then paragraph (b) of Article 3.5.1 applies again and allocates the residual Financial Accounting Net Income or Loss to the next Constituent Entity-owner up the ownership chain (unless the Ownership Interest holder is the UPE, in which case Article 3.5.1(c) applies). Thus, if all the Constituent Entities are Tax Transparent Entities (i.e. a Tax Transparent Structure), all of the MNE Group's income or loss is ultimately allocated to the UPE under Article 3.5.1 (b) and (c).

215. Article 3.5.1(b) applies only after the application of the rule in Article 3.5.1(a). This means that the allocation of Financial Accounting Net Income or Loss to the Constituent Entity-owner has to be reduced by any amount already attributed to a PE in accordance with Article 3.5.1(a). This prevents allocation of the same amount of income or loss to the PE and to the Constituent Entity-owner of the Tax Transparent Entity. This also means that no Financial Accounting Net Income or Loss would be allocated to a stateless Tax Transparent Entity.

216. The phrase "in accordance with their Ownership Interests" is intended to ensure that the amount of Financial Accounting Net Income or Loss remaining after allocation to a PE is allocated among the Constituent Entity-Owners in accordance with their interest in such income. For example, the Ownership Interests of a Tax Transparent Entity are held as follows: 40% by a non-resident Constituent Entity-owner and the remaining 60% of the Ownership Interests are divided equally by two resident Constituent Entity-owners. The Tax Transparent Entity has an office in the jurisdiction where it is located and under the applicable tax provisions, such fixed place of business creates a PE in that jurisdiction for the non-resident owner and 40% of the Tax Transparent Entity's income is allocated to a PE. The remaining 60% of income is allocated to the Constituent Entity-owners in accordance with Article 3.5.1(b) (30% each).

217. The term Ownership Interests is defined in Article 10.1 as any equity interests that carries rights to the profits, capital or reserves of the Entity. In the context of Flow-through Entities, it shall take into

account the rights on income or profits attached to the equity interests, including any agreements or contracts that derive from such interests, because Article 3.5.1 is a profit and loss allocation rule.

218. In some situations, however, there could be a mismatch between the amount of profits allocated to the Constituent Entity-owner under the fiscal transparency rules of its jurisdiction and the amount of profits to which the Constituent Entity-owner is entitled in accordance with the rights attached to the equity interests. Article 3.5.1(b) applies to the extent that the Entity is treated as a Flow-through Entity and a Tax Transparent Entity in accordance with Article 10.2.1. Therefore, Article 3.5.1(b) follows the treatment under tax law which aligns the allocation of income, expenses, profits or losses under GloBE Rules with the outcome provided by the domestic tax laws of the Constituent Entity-owner and the Flow-through Entity.

219. For example, A Co is an Entity located in jurisdiction A that holds 60% of the equity interests of B Co, a Flow-through Entity created under the domestic law of jurisdiction B. A Co and B Co are Constituent Entities of the same MNE Group, while the holders of the remaining 40% of the equity interests are not part of the Group. A Co has an agreement with the other equity interest holders that provides A Co with an additional right attached to its equity interest entitling A Co to 70% of B Co's profits (instead of 60%) for a five-year period starting after B Co's incorporation. Jurisdiction A treats B Co as fiscally transparent but does not recognise the effect of the agreement between A Co and the rest of the equity interest holders and therefore does not treat the agreement as giving A Co any additional 10% entitlement to the profits of B Co. This means that under jurisdiction A's domestic tax law, only 60% of B Co's profits are considered as being derived by A Co during the five-year period referred to above.

220. Under the GloBE Rules, A Co holds 70% of the Ownership Interests of B Co during the five-year period of the agreement. Under Article 3.5.3, 30% of the Financial Net Income of B Co is reduced because it is the amount allocated to owners that are not Group Entities based on their Ownership Interests. The remaining 70% of the Financial Net Income is allocated to A Co under Article 3.5.1(b) because jurisdiction A considers that B Co is entirely fiscally transparent such that all of the profits of B Co are being derived by its owners (including A Co). The fact that jurisdiction A does not treat the agreement between A Co and the other equity interest holders as giving A Co an additional entitlement to 10% of the profits of B Co is not relevant to the income allocation under Article 3.5.1(b) as long as jurisdiction A treats B Co as entirely fiscally transparent (i.e. a Tax Transparent Entity).

Exception for UPEs and Reverse Hybrids

221. Article 3.5.1(c) allocates the Financial Accounting Net Income or Loss of two types of Entities: (i) a Tax Transparent Entity that is the UPE of the MNE Group, and (ii) a Reverse Hybrid Entity. In both cases, the residual Financial Accounting Net Income or Loss is allocated to the Entity itself and not to its Ownership Interest holders. For purposes of applying Article 3.5.1(c), a Tax Transparent Entity shall be treated as the UPE of the MNE Group if that Entity would be the UPE of the MNE Group but for the fact that its Controlling Interests are held by an Excluded Entity.

222. Where the Tax Transparent Entity is the UPE of the MNE Group, the Financial Accounting Net Income or Loss is allocated to the Entity instead of the owners, because the owners are not Constituent Entities of the MNE Group required to apply the GloBE Rules. Article 7.1 provides additional rules that apply when a Flow-through Entity is the UPE of a MNE Group.

223. In the case of a Reverse Hybrid Entity, the Financial Accounting Net Income or Loss remains attributable to the Entity and it is not allocated to its owners, because according to the owner's tax legislation, the Entity is not fiscally transparent and its income or loss is not directly taxed in the hands of its owners.

224. As in Article 3.5.1(b), the allocation of Financial Accounting Net Income or Losses to the UPE Tax Transparent Entity or Reverse Hybrid Entity has to be reduced by any amount already attributed to a PE in accordance with Article 3.5.1(a) to prevent double-counting.

Article 3.5.2

225. Article 3.5.2 states that Article 3.5.1 applies separately with respect to each of the Ownership Interests in the Flow-through Entity in accordance with the applicable tax rules. It recognises that the same Flow-through Entity can be treated as a Tax Transparent Entity by some of its owners and a Reverse Hybrid Entity by its other owners. In such cases, the rules in Article 3.5.1 are applied separately from the perspective of each Constituent Entity-owner. In other words, Article 3.5.1 applies the Tax Transparent Entity treatment with respect to Constituent Entity-owners that treat the entity as tax transparent, and applies the Reverse Hybrid Entity treatment with respect to the other Constituent Entity-owners.

Article 3.5.3

226. Article 3.5.3 deals with the situation where the Flow-through Entity has non-Group owners. The provision reduces the Financial Accounting Net Income or Loss of the Flow-through Entity by the amount that belongs to the non-Group owners. This ensures that the jurisdictional ETR of the Constituent Entities is properly computed because it does not take into account any taxes paid by non-Group members.

227. The reduction made in accordance with this provision is made prior to the application of Article 3.5.1. Therefore, Article 3.5.3 impacts Article 3.5.1 as follows:

- a. the Financial Accounting Net Income or Loss of a PE referred in Article 3.5.1(a) will reflect only the portion that belongs to Group Entities;
- b. the full amount of the remaining Financial Accounting Net Income or Loss of the Flow-through Entity is allocated to Constituent Entities in accordance with Article 3.5.1(b) and (c).

228. For example, Hold Co is an Entity located in Country A and the UPE of an MNE Group. It holds 60% of the Ownership Interests of B LP, a Tax Transparent Entity created in Country B. The remaining 40% of the Ownership Interests of B LP are held by non-Group Entities (the “minorities”), which are also located in Country A. B LP has a store in Country B. Country B considers that this store constitutes a PE for Hold Co and the minorities. The Financial Accounting Net Income of B LP is 200. Only 100 of the Financial Accounting Net Income of B LP is attributable to the PE and taxed in Country B.

229. Under Article 3.5.3, the Financial Accounting Net Income of B LP is reduced by 80 because that is the amount that is attributable to the minorities (200 x 40%). The remaining amount (120) is allocated in accordance with Article 3.5.1. First, 60 is allocated to the PE in accordance with Articles 3.5.1 (a) and 3.5.2 because, after backing out the minorities’ share, this is the amount that remains of the PE income which is attributable to the Ownership Interests held by the Group Entities. The other 60 is allocated to Hold Co under Articles 3.5.1(b) and 3.5.2 because B LP is a Tax Transparent Entity whose income is allocated to its Constituent Entity-owners.

230. If the Consolidated Financial Statements of the MNE Group include a Covered Tax that is associated with the Financial Accounting Net Income that has been reduced by Article 3.5.3, then the amount of such Covered Tax has to be reduced in the same proportion in accordance with Article 4.1.3(a). That Article provides that Covered Taxes shall be reduced by the amount of current tax expense with respect to income excluded from the GloBE Income or Loss. This could be the case, for example, where the Flow-through Entity is subject to source taxation in a third jurisdiction that imposes the tax directly on the Entity and such taxes are reflected in its financial statements and in the Consolidated Financial Statements of the MNE Group. In the example included in the previous paragraphs, the amount of Covered Tax that would be reduced would be 40%, in accordance with the proportion of income that has been reduced.

231. This provision also applies where the Ownership Interests of the Flow-through Entity are held by non-Group members through a Tax Transparent Structure (i.e. a chain of Tax Transparent Entities). A Tax Transparent Structure is defined in Article 10.2.3.

Article 3.5.4

232. Article 3.5.4 sets out two cases where Article 3.5.3 does not apply. The first one is included in paragraph (a) which covers the case where the UPE is a Flow-through Entity. Paragraph (b) covers the situation where the Flow-through Entity is held by a Flow-through UPE through a Tax Transparent Structure. These cases are not contemplated in Article 3.5.3 because all of the owners of the Flow-through Entity are non-Group owners, which is covered by Article 7.1.

Article 3.5.5

233. Article 3.5.5 requires a Flow-through Entity to reduce its Financial Accounting Net Income or Loss by the amount of its income allocated to other Constituent Entities (Constituent Entity-owners or PEs). This is necessary to avoid double-counting that income or loss under the GloBE Rules.

References

- IFRS Foundation (2022), *International Financial Reporting Standards*, <https://www.ifrs.org/>. [2]
- OECD (2017), *Model Tax Convention on Income and on Capital: Condensed Version 2017*, OECD Publishing, Paris, https://dx.doi.org/10.1787/mtc_cond-2017-en. [1]
- OECD (2009), *Recommendation of the Council on Tax Measures for Further Combating Bribery of Foreign Public Officials in International Business Transactions*, <https://legalinstruments.oecd.org/en/instruments/OECD-LEGAL-0378>. [3]

Notes

¹ The application of Article 3.2.1 is illustrated in the Examples to the Commentary on the Model GloBE Rules under Pillar Two: <https://www.oecd.org/tax/beps/tax-challenges-arising-from-the-digitalisation-of-the-economy-global-anti-base-erosion-model-rules-pillar-two-examples.pdf>.

² 25 May 2009 [C(2009)64]; available at <https://legalinstruments.oecd.org/en/instruments/OECD-LEGAL-0378>.

³ The application of Article 3.2.3 is illustrated in the Examples to the Commentary on the Model GloBE Rules under Pillar Two: <https://www.oecd.org/tax/beps/tax-challenges-arising-from-the-digitalisation-of-the-economy-global-anti-base-erosion-model-rules-pillar-two-examples.pdf>.

⁴ The application of Article 3.2.6 is illustrated in the Examples to the Commentary on the Model GloBE Rules under Pillar Two: <https://www.oecd.org/tax/beps/tax-challenges-arising-from-the-digitalisation-of-the-economy-global-anti-base-erosion-model-rules-pillar-two-examples.pdf>.

⁵ The application of Article 3.2.7 is illustrated in the Examples to the Commentary on the Model GloBE Rules under Pillar Two: <https://www.oecd.org/tax/beps/tax-challenges-arising-from-the-digitalisation-of-the-economy-global-anti-base-erosion-model-rules-pillar-two-examples.pdf>.

⁶ The application of Article 3.3.1 is illustrated in the Examples to the Commentary on the Model GloBE Rules under Pillar Two: <https://www.oecd.org/tax/beps/tax-challenges-arising-from-the-digitalisation-of-the-economy-global-anti-base-erosion-model-rules-pillar-two-examples.pdf>.

4 Computation of Adjusted Covered Taxes

1. The rules of Chapter 3 determine the GloBE Income or Loss for each Constituent Entity in the MNE Group. Chapter 4 contains the rules that determine the amount of taxes that are to be associated with that GloBE Income or Loss for purposes of calculating the ETR, which in turn feeds into the Top-up Tax calculation described in Chapter 5. The operative term in Chapter 4 is Adjusted Covered Taxes and only amounts that meet this definition are included in the numerator of the ETR calculation. The definition of Adjusted Covered Taxes starts with Covered Taxes.

2. The definition of Covered Taxes is set out in Article 4.2. As described further in the Commentary to that definition, the term is broadly defined to include Taxes imposed on a Constituent Entity's income or profits as well as Taxes that are functionally equivalent to such income taxes and Taxes on retained earnings and corporate equity. It does not include Taxes such as indirect taxes, payroll and property taxes, which are not based on a measure of income or Top-up Taxes imposed under the GloBE rules themselves.

3. Building on the concept of Covered Taxes, Chapter 4 then makes a number of adjustments to arrive at Adjusted Covered Taxes. These adjustments include a mechanism to take into account Taxes of a Constituent Entity that are not recorded in the tax line of the profit and loss statement and to exclude Taxes that are not related to GloBE Income or Loss. Further adjustments are made to allocate certain cross-border Taxes to the proper Constituent Entity, such as taxes imposed under a Controlled Foreign Corporation regime or upon a Tax Transparent Entity. Article 4.4 provides for a mechanism to address temporary differences, which is based on the mechanisms of deferred tax accounting, while Article 4.5 allows MNE Groups to use an optional simplified rule that can be applied in lieu of the deferred tax accounting approach set out in Article 4.4. Article 4.6 sets out the rules for dealing with post-filing changes to a Constituent Entity's liability for Covered Tax.

Article 4.1 - Adjusted Covered Taxes

Article 4.1.1

4. The starting point for the computation of the taxes to be taken into account in the ETR calculation for GloBE purposes is the current tax expense that is accrued in the Financial Accounting Net Income or Loss of a Constituent Entity with respect to Covered Taxes, as defined under in Article 4.2. Thus, to the extent that current tax expense accrued for Financial Accounting Net Income or Loss includes amounts that are not accrued in respect of Covered Taxes, such as property or excise Taxes, those amounts are excluded from the taxes that are taken into account in the ETR calculation for GloBE purposes under the opening language in Article 4.1.1 without the need for a specified adjustment identified in paragraphs (a), (b) and (c) of Article 4.1.1.

- a. The adjustments to be made under paragraph (a) are Additions to Covered Taxes and Reductions to Covered Taxes which are described in Articles 4.1.2 and 4.1.3 respectively and discussed further in the Commentary below.

- b. The adjustments required under paragraph (b) are with respect to the Total Deferred Tax Adjustment Amount which is described in Article 4.4 and discussed further in the Commentary to that Article below.
- c. Paragraph (c) provides that the increase or decrease in Covered Taxes that is not included in current or deferred tax expense, but is recorded in equity or OCI shall be treated as an adjustment to Covered Taxes when the amounts of income or loss to which such taxes relate is taken into account in the computation of GloBE Income or Loss. This provision ensures that when Covered Taxes are incurred with respect to items included in the computation of GloBE Income or Loss, such Covered Taxes are taken into account even if they are not recorded in current or deferred tax expense and reported in the profit and loss statement. However, this adjustment shall only apply where the amount of income or loss to which the Covered Taxes relate is subject to tax under local tax rules. Paragraph (c) may apply, for example, where a Constituent Entity is subject to tax on gains and losses that were taken into account under OCI pursuant to the revaluation method for property, plant and equipment. When such a gain is included in the computation of GloBE Income or Loss, the associated increase in Covered Taxes will be taken into account under this paragraph. Conversely, when a loss arises in the same manner, the reduction in associated Covered Taxes will reduce Covered Taxes under this paragraph. See further discussion of the Included Revaluation Method Gain or Loss in the Commentary to Article 3.2.1(d) in respect of the Adjustments to determine GloBE Income or Loss.

Article 4.1.2

5. Article 4.1.2 requires certain additions to the Adjusted Covered Taxes to be taken into account for GloBE purposes in order to ensure that all Covered Taxes are properly captured and attributed to the Constituent Entity. An adjustment may be required under Article 4.1.2 because the range of items identified as income taxes in the financial statements may be narrower than the items that fall within the definition of Covered Taxes for the purposes of the GloBE Rules. There are four types of adjustments required under paragraphs (a) to (d).

- a. The definition of Covered Taxes is generally broader than the scope of Taxes that qualify as income taxes under financial accounting principles. Thus, some Covered Taxes may not be recorded as an income tax expense in the financial statements of a Constituent Entity. Instead, they may be expensed in the computation of profit and loss before tax. Accordingly, paragraph (a) adds back to the measure of Adjusted Covered Taxes, any accrued liability for Covered Taxes that was reported as an ordinary expense, rather than income tax expense, in the financial statements. A corresponding adjustment is made to the Financial Accounting Net Income or Loss in computing the GloBE Income or Loss pursuant to Article 3.2.1(a). For example, a Tax on corporate equity is a Covered Tax that may be recorded as an expense in determining a Constituent Entity's profit or loss before income tax, rather than in the current tax expense. To ensure consistency, this Tax is added back to GloBE Income or Loss and added to the current tax expense in the determination of Adjusted Covered Taxes.
- b. Paragraph (b) adds the amount of GloBE Loss Deferred Tax Asset that is used in a Fiscal Year. The GloBE Loss Deferred Tax Asset is available when an election is made under Article 4.5. This election, discussed in greater detail in the Commentary to Article 4.5, provides for a deemed loss deferred tax asset in lieu of applying the modified deferred tax accounting rules of Article 4.4. This GloBE Loss Deferred Tax Asset must be added to Adjusted Covered Taxes in the computation of the ETR for the jurisdiction in the Fiscal Year in which the attribute is used. Under Article 4.5, the GloBE Loss Deferred Tax Asset

attribute is used when GloBE Income is earned in a Fiscal Year subsequent to having incurred a GloBE Loss.

- c. Paragraph (c) adds the amount, if any, of Covered Taxes paid related to an uncertain tax position but only to the extent of the amount that was previously treated as a reduction to Covered Taxes under Article 4.1.3(d). However, as discussed in greater detail in the Commentary to Article 4.2.1, any penalties or interest expense accrued or paid with respect to such uncertain tax position shall not be included in this addition to Covered Taxes. As discussed in greater detail in the Commentary to Article 4.1.3(d) below, when tax expense is accrued with respect to uncertain tax positions, such amount is not included in Adjusted Covered Taxes given the uncertainty as to if, and when, such amount will be paid. However, once the amount is paid, it is appropriate to include the amount in Covered Taxes.
- d. Paragraph (d) adds any amount of refund or equivalent credit in respect of a Qualified Refundable Tax Credit that has been recorded as a reduction to current tax expense. A Qualified Refundable Tax Credit is defined in Article 10.1 as a refundable tax credit designed in a way such that it becomes refundable within 4 years from when a Constituent Entity satisfies the conditions for receiving the credit under domestic law of a jurisdiction in which the Constituent Entity is located. Qualified Refundable Tax Credits are treated as income items in the computation of GloBE Income or Loss. Accordingly, when such credit or refund is granted, any amount that has been recorded as a reduction to current tax expense in the Constituent Entity's financial accounts is reversed-out in the same Fiscal Year the current tax expense is recorded in order to prevent the ETR for the jurisdiction being understated by such a reduction in Covered Taxes. The GloBE Rules provide for a corresponding adjustment to the Financial Accounting Net Income or Loss that treats the amount of Qualified Refundable Tax Credit as income in the year the entitlement to such credit accrues (see the Commentary to Article 3.2.4).

Article 4.1.3

6. Article 4.1.3 requires subtraction of several types of Covered Taxes to ensure that the ETR calculation for the relevant Constituent Entity reflects only taxes that arise in respect of GloBE Income or Loss and that are expected to be paid within three years.

Paragraph (a)

7. Paragraph (a) removes the amount of Covered Taxes with respect to income excluded from the computation of GloBE Income or Loss under Chapter 3. It follows that when an item of income is not included in the computation of GloBE Income or Loss that the taxes associated with such income shall not be taken into account in the computation of the ETR for the GloBE Income or Loss in the jurisdiction. Many of the income items excluded from a Constituent Entity's computation of GloBE Income or Loss will relate to returns, including dividends and gains, on share or equity investments. Such items often benefit from full or partial exemption regimes, however, these and other excluded income items may be subject to Covered Taxes in certain jurisdictions or circumstances. In such cases, Article 4.1.3 requires that such taxes be excluded from Covered Taxes when the item of income upon which such tax is imposed is excluded from the computation of GloBE Income or Loss.

8. Assume, for example, a Constituent Entity is subject to tax on dividends that are received from a significant minority (e.g. 25%) investment in a corporation. This tax relates to income that is not taken into account under the GloBE Rules pursuant to Article 3.2.1(b) and therefore the corresponding taxes should be excluded from the determination of Adjusted Covered Taxes. Another example could be a Constituent Entity that owns a minority interest in a partnership that is accounted for using the equity method for

financial accounting purposes. That Constituent Entity may be subject to net basis taxation on its share of a partnership's net income. However, because income from the Ownership Interest in the partnership is accounted for using the equity method of accounting, it is generally excluded from the Constituent Entity-owner's GloBE Income or Loss, and if the tax expense associated with that interest is included in current tax expense, it must also be subtracted to determine Adjusted Covered Taxes.

9. The adjustment under paragraph (a) also encompasses Covered Taxes on certain international shipping income. CIT or tonnage tax accrued by a Constituent Entity with respect to its International Shipping Income or Qualified Ancillary International Shipping Income would meet the definition of Covered Taxes, either under Article 4.2.1(a) as a Tax on income or under Article 4.2.1(c) as a Tax imposed in lieu of a generally applicable CIT. To the extent relevant international shipping or ancillary income is excluded from a Constituent Entity's GloBE Income or Loss pursuant to the exclusion in Article 3.3, the Covered Taxes accrued with respect to such income must also be excluded from the GloBE ETR calculation. However, Covered Taxes arising in connection with any amount of income from qualifying ancillary activities that exceeds the limitation in Article 3.3.4 are included in Adjusted Covered Taxes because the related income is included in the computation of GloBE Income or Loss.

10. Where paragraph (a) applies it will be necessary to quantify the amount of Covered Taxes to be excluded. To the extent no tax is imposed upon the income item (i.e., a dividend that is exempt from taxation under domestic law) there will be no tax to exclude. Where the entire amount of the income item is excluded, the excluded taxes must be determined on the same basis without regard to any related expenses. This means, for example, that in the case of a withholding tax on an excluded dividend, the entire withholding tax is excluded, however, in the case of a CFC charge on a minority interest, that portion of the shareholder's income tax attributable to the CFC inclusion must be excluded from the Constituent Entity's Adjusted Covered Taxes when calculating the GloBE ETR. Note that if an item of income is partially excluded from GloBE Income or Loss, paragraph (a) shall apply only to the extent of the excluded portion.¹

11. While paragraph (a) removes an amount of Taxes from the Adjusted Covered Taxes of the Constituent Entity that accrued the Taxes, those Taxes may not disappear from the GloBE tax calculation entirely if they have been allocated to another Constituent Entity pursuant to Article 4.2.1. For example, in the case of Covered Taxes arising in respect of dividends or other distributions from another Constituent Entity, paragraph (a) removes the taxes from the Adjusted Covered Taxes of the Constituent Entity that received the distribution and accrued the tax expense, however such Taxes are allocated to, and included in the Adjusted Covered Taxes of, the distributing Constituent Entity pursuant to Article 4.3.2(e). Although dividends received from other Constituent Entities are excluded from the GloBE Income or Loss, Taxes on those dividends represent new or additional taxes on the income of the distributing Constituent Entity that has been included in the GloBE Income or Loss. Thus, such Covered Taxes are properly taken into account in computing the ETR of the Constituent Entity that distributed the underlying income. The key distinction between Covered Taxes imposed on intra-group dividends, i.e. dividends received from another Constituent Entity, and Covered Taxes imposed on other Excluded Dividends and equity method income is that the underlying income that funded the intra-group dividend was previously included in the MNE Group's GloBE Income or Loss when earned. Therefore Taxes paid on such distributed income are included in the distributing Constituent Entity's Adjusted Covered Taxes and, ultimately, in the numerator of the ETR computation.

12. Similarly, subject to the limitations of Article 4.3.3, Covered Taxes arising in connection with an income inclusion under a CFC Tax Regime imposed on another Constituent Entity are allocated to, and included in the Adjusted Covered Taxes of, the Constituent Entity CFC pursuant to Article 4.3.2(c). To the extent Covered Taxes are not allocated because of the operation of Article 4.3.3, such Covered Taxes are included in the Adjusted Covered Taxes of the Constituent Entity-owner.

Paragraph (b)

13. A Non-Qualified Refundable Tax Credit may be treated, for financial accounting purposes, as income of Constituent Entity. However, for GloBE purposes these Non-Qualified Refundable Tax Credits are excluded from the computation of GloBE Income or Loss pursuant to Article 3.2.4 and are treated as a reduction in the tax expense of the Constituent Entity. Article 4.1.3(b) achieves this by subtracting from the current tax expense the amount of credit or refund in respect of a Non-Qualified Refundable Tax Credit to the extent that such amount is not already recorded as a reduction to the current tax expense. Paragraph (b) therefore compliments the operation of Article 3.2.4 by ensuring that any Non-Qualified Refundable Tax Credit is treated as a reduction to current tax expense rather than an additional income item in the GloBE ETR calculation.

Paragraph (c)

14. Paragraph (c) removes any amount of Covered Taxes refunded or credited to a Constituent Entity in cases where the credit or refund has not already been treated as an adjustment to current tax expense in the financial accounts. It does not apply to Qualified Refundable Tax Credits. This paragraph ensures that to the extent a Constituent Entity receives a refund or credit of claimed Covered Taxes that this amount is still treated as a reduction in the computation of Adjusted Covered Taxes for the Fiscal Year in which the refund or credit is accrued or received. This is the case even where the Constituent Entity's accounting principles or policy did not treat that amount as an adjustment to the current tax expense. The application of paragraph (c) will be limited, because Article 4.6.1 governs adjustments to the liability for Covered Taxes for a previous Fiscal Year. Paragraph (c) will apply when such a refund or credit is not an adjustment to a Constituent Entity's liability for Covered Taxes for a previous Fiscal Year.

15. Paragraph (c) would apply, for example, if a jurisdiction provided a credit for previously incurred taxes on corporate equity where the tax and the corresponding credit was taken into account as an ordinary expense or income for financial reporting purposes in the year of the credit. This paragraph also applies to refunds and credits in respect of Covered Taxes when the refund or credit is made to a different Constituent Entity than the entity that originally incurred the tax expense. Paragraph (c) may apply to refunds and credits in respect of Covered Taxes paid or accrued in a current or previous Fiscal Year (subject to the overriding operation of Article 4.6).

Paragraph (d)

16. Paragraph (d) removes the amount of current tax expense which relates to an uncertain tax position. Current tax expense related to uncertain tax positions is disallowed, given the MNE Group's determination (and possibly its explicit or implicit assertion to the relevant tax authority) that the taxes are not owed and the high degree of uncertainty with respect to whether such amounts will be paid in a future period. Although the precise criteria may differ under Acceptable Financial Accounting Standards, uncertain tax positions generally result when a Constituent Entity takes a filing position that is not more likely than not to be sustained upon examination. Financial accounting standards require that a reserve is established for such positions. If the filing position is sustained, the reserve is released, meaning the expense is reversed and a corresponding amount of income is reflected in the financial accounts. Given the nature of such accruals, the movement in these amounts may not be included in Adjusted Covered Taxes unless and until the amount is actually paid.

Paragraph (e)

17. Paragraph (e) provides that any amount of current tax expense that is not expected to be paid within three years of the last day of the Fiscal Year shall be treated as a reduction to Covered Taxes. This rule supports the application of Article 4.6.4 which requires the recapture of material amounts previously

claimed as Covered Taxes and not paid within three years of the last day of the Fiscal Year. Under paragraph (e), if the taxpayer has no expectation to pay the tax within the three-year timeframe, it may not be included in the computation of Adjusted Covered Taxes. Because timely payment of liability for Covered Taxes is within the control of the MNE Group, there is no mechanism to include amounts paid after expiration of the three-year period in Adjusted Covered Taxes. This also prevents an abuse whereby a Constituent Entity could assert that it does not intend to pay the tax in a year where the Constituent Entity is well over the Minimum Rate, and then subsequently pays the tax liability in a year in which it is below the Minimum Rate, using the rule to escape what would otherwise be Top-up Tax liability. Paragraph (e) applies with respect to amounts of current tax expense, accordingly post-filing adjustments, such as additional tax liability resulting from a subsequent audit, will not fall within the scope of this paragraph since such amounts are not included in current tax expense. Article 4.6 provides the rules with respect to Covered Taxes paid as a result of a post-filing adjustment. In addition, there is a special rule set forth in Article 4.1.2(c) to include amounts paid with respect to uncertain tax positions, which permits the inclusion of such amounts irrespective of the operation of this paragraph.

Article 4.1.4

18. The adjustments made in Articles 4.1.1 to 4.1.3 may overlap such that a single levy could be described in two adjustment categories. However, Article 4.1.4 clarifies that Covered Taxes can only be included in the Adjusted Covered Taxes of a single Constituent Entity and they can be included only once. If a levy is described in two adjustment categories, the amount of Covered Taxes accrued in respect of such levy for the Fiscal Year is therefore not counted twice in the determination of Adjusted Covered Taxes.

Article 4.1.5

19. Article 4.1.5 provides a special rule that applies in limited circumstances when there is no Net GloBE Income in a jurisdiction for the Fiscal Year and the Constituent Entity has a deferred tax asset that has arisen due to a permanent difference (e.g., a loss attributable to an amount that is not deductible for GloBE purposes) in the same Fiscal Year. This fact pattern may occur when the local tax rules in the Constituent Entity's jurisdiction grant a deduction from income that is in excess of the amount that would be allowed for financial accounting purposes and where that difference between GloBE and local tax rules will not reverse over time. Examples of items that could give rise to these type of excess losses include notional interest deductions or a deduction that is in excess of economic cost (i.e. a super deduction). Permanent differences that result in such excess losses may also arise where a jurisdiction exempts an item of income or gain that is included in GloBE Income or Loss in a Fiscal Year where the Constituent Entity still has an overall economic loss for the year. Accordingly, the local tax loss is greater than the amount of loss recognised for GloBE purposes, triggering the application of Article 4.1.5. The generation of a GloBE Loss Deferred Tax Asset under Article 4.5 is not expected to result in Top-up Tax under Article 4.1.5 because, when elected, Article 4.5 applies in lieu of Article 4.4.

20. In these cases simply allowing a Constituent Entity to use its local tax loss as the starting point for determining its Total Deferred Tax Adjustment Amount under Article 4.4 would undermine the integrity of the GloBE Rules by effectively allowing the Constituent Entity to substitute the (more generous) local tax rules for those agreed under the GloBE. One option would have been to require the Constituent Entity to make an adjustment to the amount of deferred tax asset in these cases to align it with GloBE outcomes. However, this would have required developing an alternative deferred tax accounting methodology for addressing these specific cases as well as mechanisms for tracking and tracing such differences over time, thereby undermining the compliance and administration benefits of relying on deferred tax accounting to address timing differences. Instead, the approach taken under Article 4.1.5 is to tax the excess benefit resulting from the permanent difference in the year it is created at the Minimum Rate but to allow the

Constituent Entity to follow the local tax rules and apply the excess deferred tax asset arising for local tax purposes to shelter income in a future year without giving rise to adverse outcomes under the GloBE Rules.

21. An Additional Current Top-up Tax charge will only arise in a Fiscal Year where the local tax loss is greater than the loss that has been recorded for GloBE purposes and the additional tax loss results from a deduction for a non-economic loss or similar permanent difference between the local tax base and GloBE Income or Loss. For example, if there is a Net GloBE Loss of (100) for a jurisdiction, the maximum amount of deferred tax asset generated in such year for GloBE purposes should be 15 (i.e. the GloBE Loss multiplied by the Minimum Rate). This amount is described in Article 4.1.5 as the “Expected Adjusted Covered Taxes Amount”. Where the loss allowed for local tax purposes is in excess of the Net GloBE Loss (for example, a local tax loss of 150) and this difference is the result of permanent differences between the local and GloBE tax base, the Total Deferred Tax Adjustment Amount under Article 4.4 will be greater than the Expected Adjusted Covered Taxes Amount. In this case Additional Current Top-up Tax of 7.5 (50*15%) would be applicable under Article 4.1.5, which will have the effect of taxing this difference at the minimum rate. Article 5.4.3 provides rules related to the allocation of the Top-up Tax arising under Article 4.1.5 among Constituent Entities located in the jurisdiction.²

Article 4.2 - Definition of Covered Taxes

22. Article 4.2 sets out the definition of Covered Taxes that are taken into account in the determination of Adjusted Covered Taxes under Article 4.1. The definition of Covered Taxes is developed solely for the purposes of the GloBE Rules and has no direct interaction with Article 2 (Taxes Covered) of the OECD Model Tax Convention (OECD, 2017^[1]), which defines the taxes within the scope of the Convention. Taxes that do not qualify for the definition of Covered Taxes under the GloBE Rules, such as excise taxes and payroll taxes, will be treated as deductible in the computation of the GloBE Income or Loss (i.e. as reductions to the denominator in the ETR calculation under Article 5.1) The fact that a Tax may be deducted from the tax base for another Covered Tax does not, however, mean that the Tax is not eligible to be considered as a Covered Tax.

23. In determining whether a Tax is a Covered Tax, the focus is on the underlying character of the Tax. The name that is given to a Tax or the mechanism used to collect it (such as through a withholding mechanism) is not determinative of its character. Whether a tax charge is levied under a jurisdiction’s CIT rules or under a separate regime or statute does not have any bearing on its underlying character. The timing of a levy does not have any bearing on the definition of Covered Taxes. Accordingly, Taxes imposed on the income of a distributing corporation at the time it distributes the income are Covered Taxes, irrespective of whether the income distribution is attributable to current or previously accumulated earnings.

Article 4.2.1

24. The definition of Tax as set out in Article 10.1 of the GloBE Rules is a compulsory unrequited payment to General Government. This is based on the OECD’s longstanding definition of Taxes used for statistical purposes, with the same definition equally used by many International Organisations (IMF, World Bank, United Nations, European Union) (OECD, 2018^[4]). General Government is a defined term in the UN-OECD National Accounts that includes the central administration, agencies whose operations are under its effective control, state and local governments and their administrations (OECD, 2018^[4]). The definition of General Government in Article 10.1 is consistent with the definition in the UN-OECD National Accounts. Taxes are unrequited in the sense that any benefits provided by government to the taxpayer are not in proportion to their payments. Thus, fees and payments for privileges, services, property, or other benefits provided by government do not qualify as Taxes. Similarly, Taxes do not include fines and penalties nor do they include interest or similar charges with respect to payments of tax liabilities after the applicable due date. The definition of Covered Taxes includes four types of Taxes described in paragraphs (a) to (d).

Paragraph (a)

25. Paragraph (a) provides that any Taxes recorded in the financial accounts of a Constituent Entity with respect to its income or profits are Covered Taxes. While there is no internationally agreed definition of an income tax, income taxes are generally levied on a flow of money or money's worth that accrues to a taxpayer during a period of time. Income taxes take into account related expenses of producing the flow of money to measure the taxpayer's net increase in wealth for the period. A definition of Covered Taxes that applies to income calculated on a net (rather than gross) basis is in line with the definition of income tax used for financial accounting purposes and therefore it is expected that a Tax recognised as an income tax for financial accounting purposes should generally qualify as a Covered Tax under the GloBE Rules. However, certain income taxes are specifically excluded from the definition of Covered Taxes under Article 4.2.2.

26. The definition encompasses not only Taxes imposed on income at the time such income is derived but also to Taxes that are imposed on a subsequent distribution of profits. Moreover, the definition includes Taxes on the income of the Constituent Entity as well as its share of income of another Constituent Entity in which it owns an Ownership Interest. Thus, Taxes imposed on the Constituent Entity's share of undistributed profits from a Tax Transparent Entity such as a partnership, Taxes imposed under a CFC Tax Regime, as well as Taxes imposed on distributions from another Constituent Entity are treated as Covered Taxes under paragraph (a). The amount of such taxes allocated in respect of an Ownership Interest in another Constituent Entity are set out in Article 4.3.

27. A Tax need not determine the taxpayer's precise change in wealth to qualify as an income tax. A definition of Covered Taxes that required taxpayers and administrators to undertake further technical analysis of the precise terms of each type of Tax in order to determine whether a particular Tax took into account an appropriate amount of relevant expenses incurred in the generation of that income would be cumbersome to apply and lead to uncertainty in the determination of the ETR. Accordingly, the definition of Covered Taxes includes Taxes that allow for a simplified estimate of net profit. For example, a Tax that allows deductions for some but not all expenses related to the relevant income would be considered an income tax, provided the deductible expenses can reasonably be considered to have been incurred in connection with deriving that income. Similarly, a Tax on income that allows a standardised deduction in place of actual expenses is generally considered an income tax if such standardised deduction is based on a reasonable method for estimating such expenses. A Tax imposed on gross income or revenue without any deductions (i.e. a tax on turnover) would not be considered an income tax. The design and substantive character of such turnover taxes generally have more similarities to consumption or sales taxes. The definition of Covered Taxes therefore does not include a Tax on a gross amount unless such a Tax is in lieu of an income tax, as discussed below in connection with Article 4.2.1(c).

28. Taxes or surcharges imposed on the net income from specific activities, such as banking, or the exploration and production of oil and gas, irrespective of whether or not they apply in addition to a generally applicable income tax, would also fall within the general definition of a Covered Tax. The definition would include a separate levy that is imposed on the net income or profits from natural resource extraction activity (or a part of a multi-component levy that is imposed on net income or profits). However, natural resource levies closely linked to extractions, for example, those that are imposed on a fixed basis or on the quantity, volume or value of the resources extracted rather than on net income or profits, would not be treated as Covered Taxes except where these levies satisfy the "in lieu of" test described below in connection with paragraph (c) of Article 4.2.1.

29. Tax on net income of a Constituent Entity under Pillar One would be treated as a Covered Tax under the GloBE Rules as a tax with respect to income or profits. Because Pillar One applies before the GloBE Rules, any income tax with respect to Pillar One adjustments will be taken into account by the Constituent Entity that takes into account the income associated with such Tax for purposes of calculating

its GloBE Income or Loss. The treatment of Pillar One taxation will be further addressed through Administrative Guidance to be developed as part of the Implementation Framework.

Paragraph (b)

30. Paragraph (b) provides that any Taxes on distributed profits imposed under an Eligible Distribution Tax System are Covered Taxes. These Taxes are discussed further in the Commentary to Article 3.2.8.

Paragraph (c)

31. Paragraph (c) provides that Taxes imposed in lieu of a generally applicable CIT are Covered Taxes. A generally applicable CIT could be one that applies to all resident corporations or one that typically applies to those resident corporations that are members of a large multinational group. A generally applicable CIT would also include an income tax imposed on a corporation but which also applies to other taxable persons such as individuals. The “in lieu of” test includes Taxes that are not described in the generally applicable income tax definition but which operate as substitutes for such taxes. This test, which is used in some jurisdictions in the context of their foreign tax credit rules, would generally include withholding taxes on interest, rents and royalties, and other taxes on other categories of gross payments such as insurance premiums, provided such taxes are imposed in substitution for a generally applicable income tax. Taxes imposed in lieu of a generally applicable CIT would also include taxes arising from the Subject to Tax Rule.

32. The “in lieu of” concept also covers Taxes that are imposed on an alternative basis (i.e. other than net income), such as Taxes based on the number of units produced or commercial surface area, and which are used as substitutes for a generally applicable income tax under the laws of the jurisdiction. Where, for example, a jurisdiction imposes a simplified methodology for calculating the income on a particular category of business or investment and this Tax is imposed in substitution for a generally applicable income tax, then that Tax falls within the definition of a Covered Tax. A Tax imposed on an alternative basis levied at state or local government level, which is creditable against a generally applicable income tax levied at the national government level, would also qualify as a Covered Tax under the “in lieu of” test to the extent that it is credited against income tax in the same jurisdiction. Such local taxes can be considered as being in substitution (partially or fully) for a generally applicable income tax and an administratively efficient way of transferring resources from national to local government within the same jurisdiction. A Tax that is imposed on an alternative basis that applies in addition to, and not as a substitute for, a generally applicable income tax under the laws of the jurisdiction would not fall under the “in lieu of” test for Covered Taxes.

Paragraph (d)

33. Paragraph (d) provides that Taxes levied by reference to retained earnings and corporate equity, including a Tax on multiple components based on income and equity, are Covered Taxes. Some jurisdictions impose Taxes on the net equity of a corporation in addition to CIT. The equity or capital of a corporation is composed of its retained earnings (i.e. the undistributed portion of the after-tax income in the Profit and Loss statement) and the contributions made by shareholders. Taxes on corporate equity may be inherently interlinked with the design of the CIT systems. For example, it may be possible under the laws of a jurisdiction to credit CIT against a corporate equity tax so that a company is allowed to reduce the corporate equity tax up to the amount of CIT that it pays in that jurisdiction. Taxes on corporate equity may also act as a supplement to CIT as part of a jurisdiction’s overall approach to the taxation of a corporation’s activities in that jurisdiction. For example, some Taxes on corporate equity may incorporate a minimum tax element to their design. Such Taxes on corporate equity are therefore an integral part of the overall system of corporate taxation in those jurisdictions.

34. Some jurisdictions impose Taxes that have multiple components to the base. Where all the components of the tax base fall within the definition of income or profit covered by the GloBE Rules, then

the tax, as a whole, is included within the definition of Covered Taxes. Other taxes may be levied in respect of a corporation's activities in a jurisdiction, and are administratively and conceptually part of the system of corporate taxation in these jurisdictions but may include both an income and a non-income element. Where such taxes are predominately a tax on an entity's income and it would be administratively burdensome to split the Tax into separate income and non-income components then such Taxes should be treated, in full, as Covered Taxes under the GloBE Rules.

35. An example of a Covered Tax with multiple components is the corporate Zakat levied by the Kingdom of Saudi Arabia. The Zakat operates as a tax on income or equity or both and is therefore properly considered a Covered Tax for the purposes of the GloBE Rules.

36. Although the definition of Covered Taxes is broader than simply income taxes, a number of commonly encountered taxes are not included in the definition. The following types of tax will generally not fall within the definition of covered taxes.

- a. Consumption taxes, such as sales taxes and value-added taxes (VATs), are not Covered Taxes under the GloBE Rules. Such taxes are calculated by reference to the consideration for a defined supply and are not Taxes on the net income or equity of a taxpayer.
- b. Excise and other taxes on inputs are not Covered Taxes under the GloBE Rules. Such Taxes arise in relation to a specific input which do not represent an accretion of income.
- c. Digital services taxes are generally designed to apply to the gross revenues from the provision of certain digital services and so would not be considered an income tax. Digital services taxes are generally designed to apply in addition to, and not as substitutes for, a generally applicable income tax under the laws of a jurisdiction, and so would not fall under the "in lieu of" test for Covered Taxes either.
- d. Stamp duty, ad valorem taxes and other taxes that are imposed on a particular transaction are not taxes on income, equity, or taxes in lieu of an income tax. They are therefore outside the scope of the Covered Taxes definition.
- e. Payroll taxes and other employment-based taxes, as well as social security contributions, are not Covered Taxes under the GloBE Rules. Payroll taxes and social security contributions are not imposed on the employer in respect of its income (or equity). This follows the well-established view of payroll taxes and social security contributions as being levied on labour income (i.e. wages and in some cases personal income) as opposed to business profits. Rather, payroll taxes and social security contributions are typically deductible from business profits in the same way that wages are deducted from taxable business profits.
- f. Property taxes based on ownership of specified items or categories of property are not Covered Taxes. Property taxes are based on the assessed value of the property, often without regard to whether the property is subject to a liability. Even where adjustments to the assessed value of property is made for liabilities against the property, this is more akin to a valuation method under a property tax than a tax that is predominantly on previous income. Property taxes are not based on income, retained earnings, or corporate equity. Neither are they Taxes imposed in lieu of a generally applicable income tax. Property taxes are therefore distinguishable from taxes based on a corporation's equity and should not be Covered Taxes under the GloBE Rules.

Article 4.2.2

37. Although Covered Taxes are defined broadly, certain Taxes are specifically excluded from the definition. These excluded Taxes generally fall into two categories – Top-up Taxes and refundable taxes.

38. Paragraphs (a) through (c) exclude Top-up Taxes under the GloBE Rules from the definition of Covered Taxes. Covered Taxes are an essential element in determining the Top-up Tax, if any, under the GloBE Rules. Including GloBE Top-up Taxes in Covered Taxes would result in a circular computation in

the Fiscal Year that the Top-up Taxes arise. Including them in Covered Taxes for subsequent Fiscal Years would undermine the agreed Minimum Rate because it would effectively include them in the numerator of the ETR computation which would effectively reduce the amount of Top-up Tax that would need to be paid for the jurisdiction in the subsequent year. Qualified Domestic Minimum Top-up Taxes are excluded from the definition of Covered Taxes for the same reasons. However, such taxes are creditable against GloBE Top-up Tax under Article 5.2.3. On the other hand, an ordinary domestic minimum tax that is not a Qualified Domestic Minimum Top-up Tax is a Covered Tax if it otherwise meets the definition of a Covered Tax.

39. Paragraph (d) excludes Disqualified Refundable Imputation Taxes from the definition of Covered Taxes. Because the timing of the refund of these Taxes is within the MNE Group's control, they are similar to a deposit and therefore are not properly taken into account in the ETR computation. For example, a taxpayer can make a deposit by prepaying the tax liability in a jurisdiction for a subsequent Fiscal Year, such a prepayment will not increase Covered Taxes in the Current Fiscal Year.

40. Lastly, paragraph (e) excludes tax expense incurred by an insurance company in respect of returns to a policyholder from the definition of Covered Taxes. This paragraph (e) applies to the extent there is an adjustment under Article 3.2.9. Pursuant to Article 3.2.9, amounts charged to policy holders for tax expense incurred by an insurance company in respect of returns to a policy holder are excluded from the computation of GloBE Income or Loss. Returns to the policy holders are treated as income of an insurance company under financial accounting standards and the insurance company effectively eliminates that income with a corresponding liability to the policyholder. The liability is typically reduced by the amount of any taxes incurred by the insurance company in respect of that income such that the insurance company is effectively reimbursed by the policy holder for the taxes incurred. Tax expense incurred in respect of returns to a policy holder should not be included in the insurance company's Covered Taxes.

Article 4.3 - Allocation of Covered Taxes from one Constituent Entity to another Constituent Entity

Article 4.3.1

41. The Tax allocation provisions in Chapter 4 follow the same pattern as the income allocation provisions. Covered Taxes are generally allocated to the Constituent Entity, including a Stateless Constituent Entity, that includes the corresponding income in the computation of its GloBE Income or Loss and then are taken into account in the ETR computation for the jurisdiction in which the Entity is located.

42. In many cases, Covered Taxes will be paid by the Constituent Entity with respect to its own income and to a tax authority in the jurisdiction in which it is located and no allocation is required. However, in some more complicated cases, Covered Taxes may be imposed on the Constituent Entity in respect of income included in another Constituent Entity's GloBE Income or Loss computation or by a jurisdiction other than the one in which the Constituent Entity is located. This is the case with respect to CFC taxes and withholding taxes, for example. In those cases, it is necessary to allocate the Covered Taxes to the relevant Constituent Entity that earned the income, subject to the limitations of Article 4.3.3. Similarly, rules are needed to properly allocate Covered Taxes of Main Entities in the case of PEs and Constituent Entity-owners in the case of Tax Transparent Entities. Finally, rules are needed to properly allocate Covered Taxes on distributions. Article 4.3.1 provides for the allocation of these Covered Taxes. The allocation of Covered Taxes under Article 4.3.1 is not limited to the current Taxes paid or accrued; it applies also to deferred Taxes under Article 4.4.

Article 4.3.2

43. Article 4.3.2 provides special allocation rules for certain cross-border taxes. These allocation rules are necessary to align the Covered Taxes with the GloBE Income to which the taxes relate, subject to certain limitations. The rules in Article 4.3.2, discussed in greater detail below, provide allocation rules for Permanent Establishments, Tax Transparent Entities, Hybrid Entities, CFC taxes, and distribution taxes.

44. The paragraphs below set out the general approach to be followed in allocating Covered Taxes for each category of cross-border taxes to which Article 4.3.2 applies. These general approaches are expected to be sufficient to allocate Covered Taxes imposed under many countries' tax regimes. However, some Covered Taxes may, due to unique features of particular countries' tax regimes, require further guidance on how to apply the rules in Article 4.3.2. The GloBE Implementation Framework provides for guidance and processes agreed by the Inclusive Framework to facilitate the co-ordinated implementation of the GloBE Rules, including the further development of the common methodology for allocating the Covered Taxes of those specific country tax regimes for which more detailed or distinct allocation rules are needed. In order to facilitate compliance by MNEs and administration by tax authorities, and to ensure consistent and co-ordinated application of Article 4.3.2 across implementing jurisdictions, the results of the further work carried out as part of the GloBE Implementation Framework would be released and made publicly available.

45. It is intended that the GloBE Rules apply after the application of the Subject to Tax Rule and domestic tax regimes, including regimes for the taxation of PEs or CFCs. Therefore, to preserve the intended rule order, domestic tax regimes should not provide a foreign tax credit for any tax imposed under a Qualified UTPR or IIR which is implemented in a foreign jurisdiction, otherwise the application of that domestic tax regime would create circularity issues since those Taxes have already been determined prior to applying the Qualified UTPR or IIR.

Paragraph (a) - Allocation to a Permanent Establishment

46. Paragraph (a) allocates Covered Taxes from a Constituent Entity to a PE. The rule applies to Covered Taxes incurred by a Main Entity or another Constituent Entity in respect of the income of a PE. The Covered Taxes are excluded from the Adjusted Covered Taxes of the Constituent Entity that incurred them and included in the Adjusted Covered Taxes of the PE.

47. The Covered Taxes arising in the Main Entity in respect of the PE income can be computed using a three-step process. The first step is to determine the amount of the PE income that is included in the Main Entity's local taxable income. The amount of PE income included may be readily available from the Main Entity's tax return or the work-papers used to prepare that return. The amount included in the Main Entity's return may be more or less than the GloBE Income allocated to the PE under Article 3.4 because it is determined under the rules for computing taxable income in the Main Entity's jurisdiction. However, the amount of PE income included in the local taxable income is the relevant figure for measuring how much local tax was paid in respect of the PE's GloBE Income.

48. The second step is to determine the Main Entity's tax liability arising from inclusion of the PE income. If the PE income inclusion is subject to Tax separate and apart from the other income of the Main Entity, the tax rate applicable to the included income can simply be multiplied by the amount of the income inclusion. If, on the other hand, the PE income inclusion is mixed with the Main Entity's other income, the Main Entity's pre-foreign tax credit tax liability on all the income needs to be determined and allocated between the PE income inclusion and the rest of the Main Entity's taxable income. In many cases, a pro rata allocation will be appropriate. In cases where the PE income is mixed with other income, if the Main Entity's total taxable income is less than the PE income inclusion, all of the pre-foreign tax credit liability is attributed to the inclusion. In other words, domestic losses and losses of other PEs allowed in the Main

Entity's taxable income computation under a credit method are first used against domestic income and then applied to PE income inclusions.

49. The third step is to determine the tax credit, if any, allowed in respect of Taxes paid by the PE. In many cases, the total credit allowed in respect of these income inclusions will be easily determinable from the Main Entity's tax returns. In some cases, however, the creditable Taxes of PEs may be included in a broader base of foreign income that includes other foreign income of the Main Entity. In these cases, the amount of the foreign tax credit attributable to the PE income has to be determined based on the rules of the jurisdiction and using reasonable assumptions where necessary.

50. The amount of Covered Taxes paid on PE income inclusions is the excess of the tax liability arising from the PE income inclusions over any credit allowed for the PE's Taxes on its income. For example, Company A incurs Tax in its residence jurisdiction on its income and the income of its PE at 20%. PE incurs tax at 12% in its jurisdiction. PE earns 100 of income and incurs 12 of tax in Year 1. Company A includes all 100 of PE income and the pre-credit tax liability in its jurisdiction is 20. However, a foreign tax credit is applied to reduce the tax charge on the PE income to 8. In this example, the 8 of tax would be excluded from Company A's Adjusted Covered Taxes and allocated to the PE because that is the actual liability with respect to the PE income.

51. The foregoing three-step process determines the amount of Tax to exclude from the Main Entity's Covered Taxes. Once that amount is determined, however, those Taxes have to be allocated to the jurisdiction of the relevant PEs if the Main Entity was subject to tax on the income of more than one PE. Generally, this will require the MNE to determine the pre-credit tax liability for each PE income inclusion and subtract the allowed credit for foreign taxes on each inclusion from the pre-credit tax liability. The rules of the Main Entity jurisdiction, including tax credit limitations, apply in making these determinations. For example, in many cases, Tax paid by the PE will be creditable only to the extent of tax liability arising from the income inclusion of that PE. In other words, cross-crediting of Taxes is not allowed. Under those circumstances, the amount of residual Tax (i.e. Tax in excess of the allowed credit for foreign taxes) on a particular PE income inclusion is easily determined by subtracting the allowed credit from the pre-credit tax liability on the income inclusion. In other cases, the creditable Taxes may be subject to limitations or cross-crediting may be allowed. In the case of credit limitations, the MNE Group will need to determine the allowed credit for foreign taxes on each PE income inclusion based on the rules of the jurisdiction, and where necessary make reasonable assumptions.

52. Determining the amount of Tax paid on a PE income inclusion is more complicated when cross-crediting is allowed because Taxes paid by one PE are allowed to reduce the tax liability arising in respect of other PE income inclusions. Cross-crediting means that the Tax paid with respect to an income inclusion from a low-taxed PE may not equal the pre-credit tax liability on the inclusion less the tax credit allowed for Taxes paid by that PE. Where cross-crediting is allowed, the Taxes paid in respect of an inclusion should be determined by subtracting the credit allowed for Taxes paid by the particular PE, and then further subtracting an appropriate amount of excess creditable Taxes paid by other PEs from the pre-credit tax liability of the PE. The appropriate amount of excess creditable taxes should be determined by allocating the total amount of excess creditable taxes among PE inclusions based on the relative residual tax liability due to each PE inclusion taking into account only creditable taxes paid by that PE (i.e. the liability after the credit for taxes paid by the PE but before excess credits are allocated). Allocating the excess creditable taxes based on relative residual tax liability determined based solely on the PE's creditable taxes will ensure that the amount of the Main Entity's Covered Taxes allocated to PEs does not exceed the amount of Taxes actually arising on the related income inclusions. Deferred tax liabilities with respect to PE income are allocated in the same manner. The rules with respect to the recognition of deferred tax liabilities are set forth in Article 4.4.

53. In the case of a Flow-through Entity Article 4.3.2(a) allocates, in accordance with the allocation of GloBE Income or Loss pursuant to Article 3.5.1(a), the underlying taxes to the PE. If for instance the

Constituent Entity-owner of a Flow-through Entity (such as a partner of Tax Transparent Entity that is a partnership which is itself also a Constituent Entity) is required to pay the tax with respect to the income attributable to the PE due to the activities undertaken through a Tax Transparent Entity that tax is allocated pursuant to Article 4.3.2 (a) from the Partner to that PE.

54. Recognizing that there is significant variation in how countries impose tax on PEs (including variation in the treatment of losses and foreign tax credits), as discussed in the first paragraph of the Commentary to this Article, the GloBE Implementation Framework includes the development of a common methodology to determine the amount of Covered Taxes allocated from a Constituent Entity to a PE in connection with specific country regimes.

Paragraph (b) - Allocation from a Tax Transparent Entity to its Constituent Entity-owner

55. Paragraph (b) allocates taxes in connection with the income of a Tax Transparent Entity that is allocated to a Constituent Entity-owner. Generally, Tax Transparent Entities are not subject to CIT in the jurisdiction where they are created. However, some Covered Taxes could be imposed at the sub-national level or local level on Tax Transparent Entities without causing them to be considered a tax resident of that jurisdiction. In other cases, the operations carried out through the Tax Transparent Entity could give rise to source taxation that could be borne by the Tax Transparent Entity.

56. In most cases, where the Tax Transparent Entity is liable to Tax on net income in a jurisdiction it will be because the activities and operations of that Entity give rise to a PE in that jurisdiction (see paragraph (b) of the definition of PE in Article 10.1). In those cases, the appropriate portion of the income of the Tax Transparent Entity that is attributable to the PE is first allocated to the PE under Article 3.5.1(a).

57. Consistent with Article 3.5.1(b), Covered Taxes that are not allocated to a PE will be assigned to the Constituent Entity-owners of the Tax Transparent Entity. Typically, this will mean that Covered Taxes imposed on a Tax Transparent Entity's income (and not attributable to any PE) will be assigned to each Constituent Entity-owner in proportion to its share of the Tax Transparent Entity's income. In the case of a Reverse Hybrid Entity, the income and Taxes would remain with the Entity itself and therefore, no allocation of Covered Taxes is needed in accordance with this paragraph.

Paragraph (c) - CFCs

58. Similar to the allocation to Permanent Establishments in paragraph (a), paragraph (c) allocates taxes imposed pursuant to a CFC Tax Regime. The same general process described in paragraph (a) above for allocating Covered Taxes imposed on the Main Entity in respect of a PE can also be applied by a Constituent Entity-owner in respect of a taxes arising under a CFC Tax Regime with the amount of any CFC Taxes included in the financial accounts of an direct or indirect Constituent Entity-owner on its share of the CFC's income being allocated to such CFC, subject to the limitations of Article 4.3.3.

Paragraph (d) - Hybrid Entities

59. Paragraph (d) allocates Taxes of Constituent Entity-owners arising in connection with the income of Hybrid Entities. If a Constituent Entity-owner of a Hybrid Entity is located in a tax jurisdiction that imposes Tax on the owner's share of the Hybrid Entity's income under a fiscal transparency regime (see discussion in Commentary to Article 10.2), the Covered Taxes included in the financial accounts of the Constituent Entity-owner should be assigned to the Hybrid Entity. The same general process described in paragraph (a) above for allocating Covered Taxes imposed on the Main Entity in respect of a PE can be used to determine the amount of taxes allocated by a Constituent Entity owner to a Hybrid Entity, however any taxes allocated to a Hybrid Entity by a Constituent Entity-owner in respect of Passive Income are subject to limitation under Article 4.3.3, which is discussed further below. If the Constituent Entity-owner is subject

to a withholding tax or net basis taxes on distributions from the Hybrid Entity, such Taxes would also be allocated to the Hybrid Entity pursuant to paragraph (e).

Paragraph (e) - Taxes on dividends and other distributions

60. Paragraph (e) allocates taxes arising in connection with distributions between Constituent Entities. This includes withholding tax and net basis taxes incurred by direct Constituent Entity-owners on distributions by Constituent Entities in respect of their stock which are allocated to the distributing Constituent Entity. Withholding taxes are imposed under the laws of the distributing Constituent Entity and are collected at the source, but the income tax is the legal liability of the Constituent Entity-owner. The rule applies to Taxes with respect to any type of distribution with respect to the stock of the distributing Constituent Entity. Thus, the rule also applies to Taxes in respect of a distribution that does not meet the definition of a dividend for tax purposes in the recipient jurisdiction or that would not be considered a distribution of retained earnings under the UPE's financial accounting standard.

61. In many cases, the distributing Constituent Entity is the Constituent Entity that originally earned the income. In other cases, the distributing Constituent Entity will be a direct or indirect shareholder of the Constituent Entity that originally earned the income. Ideally, Covered Taxes incurred by Constituent Entities with respect to distributions should be assigned to the tax jurisdiction of the Constituent Entity that originally earned the underlying income. However, tracking and tracing distributions through the ownership chain would be extremely complex and burdensome, particularly where an entity controls multiple Constituent Entities. Accordingly, paragraph (e) provides that such Taxes should be assigned to the jurisdiction of the immediate Constituent Entity that distributed the dividend that triggered the tax liability.

Article 4.3.3

62. Article 4.3.3 imposes a limitation on the “push-down” of Taxes from a Constituent Entity-owner that are attributable to Passive Income of the subsidiary Constituent Entity. This rule is designed to maintain the integrity of the jurisdictional blending rules in relation to mobile income. In the absence of Article 4.3.3, the rules in Article 4.3.2(c) and (d), which allocate Taxes paid by a Constituent Entity-owner under a CFC Tax Regime or in respect of a Hybrid Entity, would effectively blend the Taxes paid on that mobile income in the Constituent Entity-owner's high tax jurisdiction with other income arising in the Low-Tax Jurisdiction. Without the rule of Article 4.3.3, an MNE Group could shift mobile income from high-tax jurisdictions to Low-Tax Jurisdictions to reduce overall tax liability (including Top-up Tax liability) in the MNE Group.

63. Under Article 4.3.3 the amount of Covered Taxes allocated pursuant to Articles 4.3.2(c) and (d) from a Constituent Entity-owner to a subsidiary in respect of Passive Income is limited to the lesser of the actual amount of Covered Taxes in respect of such Passive Income or the Top-up Tax Percentage that applies in the subsidiary jurisdiction, (determined without regard to the taxes to be pushed down to the subsidiary under the CFC Tax Regime or fiscal transparency rule), multiplied by the amount of the subsidiary's Passive Income that is includible under the CFC Tax Regime or fiscal transparency rule. Any remaining Covered Taxes of the subsidiary Constituent Entity-owner incurred with respect to such Passive Income after the application of this Article are included in the Constituent Entity-owner's Adjusted Covered Taxes. The practical effect of this rule is therefore to cap the total Covered Taxes on such passive income (including the taxes allocated to the subsidiary under the CFC or tax transparency regime) to the minimum rate.³

Article 4.3.4

64. Article 4.3.4 ensures that in cases where the GloBE Income of a PE is treated as GloBE Income of the Main Entity pursuant to Article 3.4.5, any Adjusted Covered Taxes associated with such income are

treated as Adjusted Covered Taxes of the Main Entity, in an amount not exceeding such income multiplied by the highest corporate tax rate on ordinary income in the jurisdiction. The highest corporate tax rate on ordinary income means the full marginal rate which a jurisdiction generally applies to categories of income which do not benefit from any exemption, exclusion, credit or other tax relief applicable to particular types of payments. This concept is further considered in paragraph 32 of the OECD's 2015 Final Report on Action 2: Neutralising the Effects of Hybrid Mismatch Arrangements. This also does not include rates which are only applied to particular business sectors (OECD, 2015^[5]).

65. This situation arises after a loss of a PE has been treated as a loss of a Main Entity under Article 3.4.5. In most cases, there will not be Taxes in the location of the PE, either because the jurisdiction allows the PE to carry-forward its loss or, more rarely, because the PE is not subject to Tax in the jurisdiction.

66. When a GloBE Loss of a PE is treated as an expense of a Main Entity under Article 3.4.5, any deferred tax asset established with respect to a tax loss of the PE jurisdiction shall not reduce the Adjusted Covered Taxes of the PE jurisdiction or the Main Entity jurisdiction. Conversely, when the deferred tax asset established by the PE reverses in the PE jurisdiction, the Adjusted Covered Taxes of the PE jurisdiction or Main Entity jurisdiction shall not be increased. Deferred tax attributes generated or used in the Main Entity jurisdiction with respect to a loss of the PE are available for use and remain subject to the other provisions of Chapter 4.

Article 4.4 - Mechanism to address temporary differences

67. Article 4.4 provides the mechanism to address temporary differences, which arise when income or loss is recognised in a different year for financial accounting and tax. The principal mechanism that the GloBE Rules use to address temporary differences is set forth in Article 4.4 and builds on deferred tax accounting, with key adjustments to protect the integrity of the GloBE Rules. An example of how Article 4.4 uses deferred tax accounting to address timing differences is set out in the paragraph below. Company A is located in Country Z which imposes a 15% CIT. In the first Fiscal Year, Company A purchases Asset M for 100 that benefits from immediate expensing under the tax laws of Country Z, but that must be amortised over five years for financial accounting purposes. Company A earns 100 of operating income in that same Fiscal Year. For domestic tax purposes, Company A has no taxable income due to the immediate expensing of Asset M. However, for financial accounting and GloBE purposes, Company A has 80 of income (100 of operating income, less 20 of amortisation). Absent Article 4.4.1, Top-up Tax of 12 would be due in the first Fiscal Year, given the 80 of income with no tax paid. However, Article 4.4.1 operates to adjust for this timing difference by permitting the deferred tax assets and liabilities of Company A to be taken into account. The temporary difference amount is 80 (i.e., the amount of income that is GloBE Income in the current Fiscal Year and that will reverse as the asset is amortised for financial accounting purposes over the next four years). To prevent this timing difference from resulting in Top-up Tax, 80 of GloBE Income should be sheltered by the Article 4.4 rules. Accordingly, the Article 4.4.1 rules, following standard tax accounting principles, will permit a deferred tax liability to be recognised in the first Fiscal Year of 12, which provides shelter for 80 of GloBE Income at the 15% Minimum Rate.

68. While Article 4.4 uses existing deferred tax accounts maintained by MNE Groups to the greatest extent possible to simplify compliance, certain adjustments are required to protect the integrity of the GloBE Rules. These adjustments include using the lower of the Minimum Rate or the applicable tax rate to calculate deferred tax assets and liabilities in order to prevent deferred tax amounts from sheltering unrelated GloBE Income. The rules also require the recapture of certain amounts claimed as deferred tax liabilities that are not paid within five years. Exceptions are provided for the most common and material book to tax differences when they relate to substance in a jurisdiction or are not prone to taxpayer manipulation. These amounts do not require monitoring for recapture.

Article 4.4.1

69. Article 4.4.1 establishes the Total Deferred Tax Adjustment Amount for a Constituent Entity, which is an amount that is added to the Adjusted Covered Taxes of a Constituent Entity for a Fiscal Year under Article 4.1.1(b). The Total Deferred Tax Adjustment Amount adjusts the Covered Taxes of a Constituent Entity to take certain deferred tax assets and liabilities into account in order to address the impact of temporary differences.

70. The starting point for the Total Deferred Tax Adjustment Amount is the amount of deferred tax expense accrued in the financial accounts of a Constituent Entity if the applicable tax rate is below the Minimum Rate or, in any other case, such deferred tax expense recast at the Minimum Rate. Deferred tax expense for the Fiscal Year is comprised of the net movement in deferred tax assets and liabilities between the beginning and end of the Fiscal Year. When established, deferred tax assets are recorded as negative tax expense (i.e., income tax benefit) whereas deferred tax liabilities are recorded as tax expense. Note that the recast of deferred tax expense may either be performed on an item-by-item basis or in the aggregate for all items recorded at the same rate, as the result should remain unchanged. When a deferred tax asset or deferred tax liability reverses it will reverse at the same amount and rate at which it has been recorded. A reversal of a deferred tax liability is negative deferred tax expense, whereas the reversal of a deferred tax asset equates to deferred tax expense. The applicable tax rate is the tax rate at which the deferred tax item is recorded. For example, if a deferred tax liability of 20 is recorded with respect to income of 100, the applicable tax rate is 20% (i.e., the tax imposed on an item of income divided by that item of income). This rate is higher than the Minimum Rate and would thus be recast at the Minimum Rate. For example, if the CIT rate in Country Z in the example in the introduction to the Article 4.4 Commentary was 30%, then the rules in Article 4.4.1 would still only recognise a deferred tax liability of 12 (i.e. 80 of additional income multiplied by the 15% Minimum Rate) in the first Fiscal Year. When such deferred tax liability reverses, the amount of the reversal will be 12.

71. To the extent deferred tax assets exceed deferred tax liabilities, deferred tax expense will be negative (i.e., an asset in lieu of a liability). This amount is typically accrued with respect to the applicable domestic tax rate (i.e., the tax rate in a jurisdiction which applies to the item of income with respect to which the deferred tax item is recorded) in a jurisdiction in order to adjust for timing differences between financial accounting recognition and domestic tax recognition. In order to use the accounts to adjust for timing differences under the GloBE Rules, the deferred tax assets and liabilities must be recast with reference to the Minimum Rate to the extent they have been recorded at a rate in excess of the Minimum Rate.

Paragraph (a)

72. Paragraph (a) of Article 4.4.1 excludes from the Total Deferred Tax Adjustment Amount, the amount of deferred tax expense with respect to any items that are excluded from the computation of GloBE Income or Loss under Chapter 3. This paragraph operates to prevent taxes associated with items not includible in the calculation of GloBE Income or Loss from being used to increase the amount of Adjusted Covered Taxes, resulting in an overstatement of the jurisdictional ETR.

73. For example, M Co is a Constituent Entity located in Country C which has a 15% corporate tax rate and subjects to tax Excluded Equity Gains and Losses. In a Fiscal Year, M Co incurs a GloBE Loss of (300) and an Excluded Equity Loss of (100). This Excluded Equity Loss is not included in the GloBE Income or Loss for Country C, because it is an Excluded Equity Loss. Accordingly, if there are no other differences between the GloBE base and the Country C tax base, the GloBE Loss for Country C is (300) whereas the domestic tax loss for Country C is (400). A deferred tax asset of 60 is established, however, for GloBE purposes only 45 may be taken into account since 15 of deferred tax asset relates to the Excluded Equity Loss of 100.

74. For example, if a Constituent Entity generates a deferred tax asset with respect to income excluded from the computation of GloBE Income or Loss, the deferred tax asset cannot subsequently be used to increase the amount of Adjusted Covered Taxes since the tax was paid with respect to an item outside of the GloBE base.

Paragraph (b)

75. Paragraph (b) operates to exclude deferred tax expense that relates to Disallowed Accruals and Unclaimed Accruals from the Total Deferred Tax Adjustment Amount. These terms are further explained in the Commentary on Article 4.4.6 and Article 4.4.7. The principal reason for excluding such amounts until paid is the speculative nature as to whether such amounts will be actually paid in the case of a Disallowed Accrual, or when the amounts will be paid in the case of an Unclaimed Accrual. The Commentary to Article 4.1.3 Paragraph (d) sets out the basis for the exclusion of current tax expense that relates to uncertain tax positions.

Paragraph (c)

76. To prevent distortions, paragraph (c) excludes valuation adjustments or accounting recognition adjustments with respect to deferred tax assets. When it is not probable that taxable profit will arise in the future against which all or part of a domestic tax loss can be applied, a valuation allowance or accounting recognition adjustment is generally required for financial accounting purposes. This valuation allowance or accounting recognition adjustment is applied to the extent of the loss that is not forecast to be usable. When an accounting recognition adjustment is recorded, the deferred tax asset is not recorded as a deferred tax asset in the financial statements to the extent it is not forecast to be usable in the future. When accounting rules require a valuation allowance, the deferred tax asset associated with the domestic tax loss is recorded in the financial statements as a deferred tax asset, however, an offsetting liability is recorded as a valuation allowance to the extent of the deferred tax asset that is not forecast to be usable. If financial forecasts change in a future period and it becomes probable that taxable profit will arise in current period or a future period, the accounting recognition adjustment or valuation allowance is reversed in the period in which the forecast changes.

77. Because the generation of deferred tax assets reduces Adjusted Covered Taxes, it is necessary to ensure that a deferred tax asset relating to a domestic tax loss is recorded in the same year as such loss for GloBE purposes. Accordingly, the rule in paragraph (c) ensures that the deferred tax asset is recorded for GloBE purposes in the same year as the economic loss which gave rise to such asset. Because valuation allowances and accounting recognition adjustments are disregarded under the GloBE Rules, a deferred tax asset will be recorded in respect of a domestic tax loss regardless of whether there is a forecast of probable future use of such attribute. As a result, a taxpayer may have recorded a GloBE deferred tax asset in respect of a carry-forward domestic tax loss that expires. A carry-forward loss cannot be used under domestic law when it is not available to offset domestic taxable income. The financial accounting rules treat deferred tax assets arising from domestic carry-forward losses as reversed when they are used to offset domestic taxable income. Therefore, such losses will not be available for use for GloBE purposes to the extent they cannot be used under domestic law. It follows that when a loss is not available for domestic law purposes, it cannot reverse under financial accounting rules, and therefore it will not be available for GloBE purposes to increase Adjusted Covered Taxes.

78. In Year 1 a Constituent Entity incurs a GloBE Loss of (100) and a deferred tax asset of (15) is generated, however, financial forecasts indicate that the tax loss will not be used in the future. Accordingly, the benefit of this tax loss is not recorded due to valuation adjustments or accounting recognition adjustments. However, this is disregarded for GloBE purposes and the deferred tax asset is generated. In Year 2, the forecast changes and the valuation adjustment or accounting recognition adjustment is reversed. This is also disregarded for GloBE purposes. In Year 3, GloBE Income of 100 is generated and

the loss deferred tax asset is used and reversed. Absent the application of paragraph (c), in this example the deferred tax asset would have been generated in Year 2, reducing Adjusted Covered Taxes in a year in which there is no Net GloBE Income and Top-up Tax would have otherwise arisen under Article 4.1.5.

Paragraph (d)

79. Paragraph (d) excludes the amount of deferred tax expense that results from a change in the applicable domestic tax rate. This amount is excluded because amounts accrued in this respect are simply changes to amounts already accrued and should not be taken into account as additional Covered Taxes in a Fiscal Year. For example if additional deferred tax expense comes through the financial statements because a tax rate has increased from 10% to 15%, this amount should not be added to Covered Taxes since it does not relate to GloBE Income in the current Fiscal Year. Articles 4.6.2 and 4.6.3 provide rules that govern how domestic tax rate changes are taken into account for GloBE purposes to ensure appropriate credit is given for tax paid.

Paragraph (e)

80. Finally, paragraph (e) excludes the deferred tax benefit with respect to the generation of tax credits as well as the deferred tax expense with respect to the use of tax credits. A tax credit is an amount that taxpayers can subtract directly from taxes owed to a government. They differ from deductions, which reduce the amount of taxable income. Instead, they directly reduce the amount of tax owed. One example of a tax credit is an investment tax credit whereby the government provides the taxpayer that incurs certain qualifying expenditure with a reduction in a future tax payable that is calculated as a percentage of the expenditure incurred. A tax credit under paragraph (e) includes tax credits granted in a jurisdiction due to a tax liability imposed in another jurisdiction or imposed on profits distributed by another entity such as foreign tax credits. Tax credits are excluded from the Article 4.4.1 Total Deferred Tax Adjustment amount because the inclusion of such amounts could lead to distortions in GloBE results. Note that Qualified Refundable Tax Credits are addressed separately in Article 4.1.2.

81. Because the generation and use of tax credits is excluded from the Total Deferred Tax Adjustment Amount, any movement in deferred tax expense arising from the generation and use of such tax credits is excluded from the computation of Adjusted Covered Taxes. For example, when an excess foreign tax credit carry-forward is generated, the deferred tax asset associated with such carry-forward will not reduce Adjusted Covered Taxes since it is excluded from the Total Deferred Tax Adjustment Amount under Article 4.4.1(e). Conversely, when such foreign tax credit carry-forward is used in a subsequent Fiscal Year, the use of such deferred tax asset will not result in an increase to Adjusted Covered Taxes for the same reason. This results in the same outcome as if no deferred tax asset for the carry-forward of a foreign tax credit was recorded at all.

82. Because deferred tax assets arising from the generation of tax credits are excluded from the Total Deferred Tax Adjustment Amount and will not reduce Adjusted Covered Taxes, the generation of tax credits should not give rise to Top-up Tax under Article 4.1.5.⁴

Article 4.4.2

83. Article 4.4.2 provides for certain adjustments to the Total Deferred Tax Adjustment Amount. The first adjustment in paragraph (a) operates to take into account any Disallowed Accrual or Unclaimed Accrual that has been paid during the Fiscal Year. As discussed in the Article 4.4.1 Commentary, such amounts were not taken into account when generated due to the speculative nature of when and whether such Taxes would be paid. However, once such Taxes are paid it is appropriate to take them into account for GloBE purposes. Although the tax paid will be included in current taxes, this may be offset by the decrease in the deferred tax liability, to the extent the deferred tax liability is included in the Total Deferred

Tax Adjustment Amount, and therefore in Adjusted Covered Taxes. As a result, it is necessary to include an amount in the Total Deferred Tax Adjustment Amount to ensure there is no net movement in the Total Deferred Tax Adjustment Amount in order to ensure that the tax is taken into account for GloBE purposes. Because Article 4.4.1(b) excludes the movement in deferred tax expense with respect to Disallowed Accruals, the decrease in deferred tax liability when a Disallowed Accrual reverses should be excluded from the Total Deferred Tax Adjustment Amount. Therefore, the amount that reverses with respect to a Disallowed Accrual need not be added under Article 4.4.2(a) since that amount is already accounted for in current tax expense without an offsetting deferred tax liability reversal for GloBE purposes. However, while the exclusions of deferred tax expense in Article 4.4.1 apply equally to exclude both increases and decreases in deferred tax expense, an Unclaimed Accrual is defined solely by reference to an increase in a deferred tax liability, and thus any subsequent decrease will not be captured by the exclusion in Article 4.4.1(b), making the rule in Article 4.4.2(a) necessary for Unclaimed Accruals.

84. Paragraph (b) permits the addition of Recaptured Deferred Tax Liabilities that have been paid during the Fiscal Year. As discussed in greater detail in the Commentary to Article 4.4.4., certain amounts claimed as Adjusted Covered Taxes must be recaptured if not paid within the time limit set forth in Article 4.4.4. Subparagraph (b) permits taking these previously recaptured Adjusted Covered Taxes into account when such amounts are paid.

85. Paragraph (c) provides for the generation of a deemed deferred tax asset when a deferred tax asset should have been generated but was not due to the recognition criteria not being met. This rule is a corollary to the rule in Article 4.4.1(c) that disregards valuation adjustments or accounting recognition adjustments. However, in some cases the deferred tax asset may not be recorded in the first place due to the criteria not being met. This subparagraph provides for the generation of the deferred tax asset for GloBE purposes in the year of the loss and the rule in Article 4.4.1(c) then subsequently disregards the generation of such deferred tax asset in subsequent years when the recognition criteria is met. This aligns the generation of the attribute with the loss to ensure that Top-up Tax is not triggered under Article 4.1.5 simply due to the fact that the recognition criteria has not been met. This is illustrated by the following example.

86. In Year 1, Constituent Entity A generates a GloBE Loss and local tax loss of (100). No deferred tax asset is generated for financial accounting purposes because the recognition criteria have not been met (i.e., there is no forecast of future profits). The application of this subparagraph (c) results in the generation of a deferred tax asset of 15 in Year 1 (this represents the DTA that would have otherwise been recorded at the Minimum Rate). In Year 2, Constituent Entity A does not earn taxable income or GloBE Income or Loss, however, the future forecasts change and the DTA of 15 is recorded for financial accounting purposes because the recognition criteria are met. This is disregarded under Article 4.4.1(c). In Year 3, the Constituent Entity earns GloBE Income of 100 and applies its domestic tax loss carry-forward. The DTA of 15 is applied in Year 3.

Article 4.4.3

87. Article 4.4.3 provides that when a deferred tax asset has been recorded at a rate lower than the Minimum Rate that such asset may be recast at the Minimum Rate when the asset is attributable to a GloBE Loss. This rule preserves the basic tenet that a GloBE Loss of EUR 1 should offset GloBE Income of EUR 1. For example, if a loss deferred tax asset was recorded at a 5% rate, a GloBE Loss of 100 would result in a deferred tax asset of 5. When 100 of income is subsequently earned, the deferred tax asset of 5 reverses and is added to Covered Taxes through the Total Deferred Tax Adjustment Amount. Absent a recast at the Minimum Rate, Top-up Tax of 10 would be due when 100 of income is subsequently earned. However, permitting a recast of the GloBE Loss at the Minimum Rate (i.e., increasing the value of the deferred tax asset recorded from 5 to 15 in respect of the GloBE Loss) prevents this outcome and provides that a loss of 100 shelters 100 of income.

88. To the extent an amount is recast at the Minimum Rate under Article 4.4.3, the recast must be done in the Fiscal Year in which the loss becomes a GloBE Loss to prevent distortive outcomes. For example, recasting in a year after the GloBE Loss is incurred could result in such recast resulting in additional Top-up Tax under the operation of Article 4.1.5. To the extent a deferred tax asset is increased by operation of this rule, it follows that like the generation of an actual deferred tax asset, that the Total Deferred Tax Adjustment Amount is decreased by the amount of incremental deferred tax asset generated.

Article 4.4.4

89. The recapture rule for categories of deferred tax liabilities that do not reverse within a specified period of time is set forth in Article 4.4.4. Unlike Recapture Exception Accruals, which are defined in Article 4.4.5, and discussed in further detail below, deferred tax liabilities recorded in other categories that do not reverse within the five Fiscal Years must be recaptured in the Fiscal Year in which the increase in the Recaptured Deferred Tax Liability was originally included in the Total Deferred Tax Adjustment Amount. This rule ensures that deferred tax liabilities recorded with respect to categories that do not relate to specific policy allowed categories are actually settled within the required period of time.

90. Each item of deferred tax expense for a Constituent Entity that is not in a category that meets the Recapture Exception Accrual definition should be tested in each Fiscal Year for recapture as necessary under the mechanics of Article 4.4.4. For example, in Year 0 a Constituent Entity reports an amount as a deferred tax liability and includes that amount in Adjusted Covered Taxes. The category of income to which the deferred tax liability relates is not listed in Article 4.4.5 as a Recapture Exception Accrual. In Year 5, which is five subsequent Fiscal Years after the amount was claimed, the deferred tax liability has not reversed and is subject to recapture as a Recaptured Deferred Tax Liability. Accordingly the Year 0 Top-up Tax calculation must be recalculated under Article 5.4, having removed such amount.

Article 4.4.5

91. The Recapture Exception Accrual rule, which provides categories of deferred tax liabilities that do not need to be monitored for recapture under Article 4.4.4, is set forth in Article 4.4.5. The list of Recapture Exception Accruals sets out the temporary differences that are both common in Inclusive Framework jurisdictions and that are generally material to MNE Groups. Such temporary differences are typically tied to substantive activities in a jurisdiction or are differences that are not prone to taxpayer manipulation. Accordingly, to reduce compliance burdens, these low-risk items that are certain to reverse over time are not required to be monitored under the rules in Article 4.4.4 for recapture.

Paragraph (a)

92. The inclusion of cost recovery allowances in paragraph (a) of Article 4.4.5 with respect to tangible assets reflects the principle that accelerated depreciation and immediate expensing regimes are common in Inclusive Framework jurisdictions and that such timing differences are certain to reverse over the life of an asset. Absent the rule in paragraph (a) of Article 4.4.5, the recapture mechanism in Article 4.4.4 could serve to disgorge the benefit of such regimes and result in the distortion of jurisdictional ETRs for assets that have a lifespan longer than the time period set forth in Article 4.4.4.

93. Generally, tangible assets consist of property that is classified as Property, Plant, and Equipment or Stockpiles for financial accounting purposes. Property, Plant and Equipment are included as assets on the balance sheet if they are tangible items that are held for use in the production or supply of goods or services, for rental to others, or for administrative purposes and are expected to be used during more than one period.

94. Tangible assets also include natural resources, such as mineral deposits, timber, oil and gas reserves, and exploration and evaluation assets. If natural resources are eligible for an accelerated cost

recovery method, or other treatment in respect of associated costs that results in timing differences between tax and accounting, paragraph (a) also applies to the corresponding timing differences. For purposes of this paragraph, whether an asset constitutes tangible property should be evaluated under the accounting standard used to determine the Financial Accounting Net Income or Loss of the Constituent Entity. Furthermore, the rule is intended to apply to deferred tax liabilities arising in connection with differences in capitalized costs associated with the particular asset. Thus, if the relevant financial accounting rules require capitalization of a broader range of costs than the relevant tax accounting rules, the associated deferred tax liabilities are treated as Recapture Exception Accruals. Similarly, if costs such as mine or oil and gas exploration and development costs that are deducted as incurred or amortised over a brief period for tax purposes and capitalised into the natural resource asset for accounting purposes, the associated deferred tax liabilities are treated as Recapture Exception Accruals.

95. Paragraph (a) also applies in the case where a tangible asset has been leased. Generally for financial accounting purposes, a lease is treated as a right of use that is depreciated and a lease liability (an obligation to make future lease payments). Upon initial recognition, the right to use the asset and the lease liability are equal and offsetting and as such there will be no net deferred tax asset or liability. Timing differences arise because when for local tax purposes, the treatment of leased assets differs from accounting such that lease payments are treated as deductible operational expenses. When such timing differences arise, paragraph (a) provides that they are not subject to the recapture rule set forth in Article 4.4.4.

Paragraph (b)

96. Paragraph (b) includes the cost of a licence or similar arrangement from the government, such as a lease or concession, for the use of immovable property or the exploitation of natural resources, where this entails significant investment in tangible assets. A right to use immovable property includes licenses for the right to use radio spectrum for telecommunications services. When the right also imposes an obligation to incur significant investment in tangible assets, the cost will be within paragraph (b). Thus, where there are differences between the relevant financial accounting rules and the relevant tax accounting rules regarding the timing of recognition of the cost of the licence or similar arrangement or related costs, or the accounting rules require capitalization of a broader range of such costs, the associated deferred tax liabilities are treated as Recapture Exception Accruals. For example, local tax laws may require the amortisation of a radio spectrum license over a fifteen year period, whereas for financial accounting purposes the useful life of such asset has been determined to be twenty years.

Paragraph (c)

97. Research and development expenses are included in paragraph (c) of Article 4.4.5, given that tax rules in Inclusive Framework jurisdictions generally permit the deduction of research and development costs, whereas some of such costs may be capitalised for financial accounting purposes. Adhering to the financial accounts with respect to the capitalisation of research and development costs could lead to unintended outcomes, including increased pressure on the application of accounting standards and differences in treatment depending upon the accounting standard utilised. Accordingly, given the commonality of deductions in Inclusive Framework jurisdictions and the materiality of research and development expenses to MNE Groups, research and development expenses are included as a Recapture Exception Accrual.

Paragraph (d)

98. De-commissioning and remediation expenses are included in paragraph (d) of Article 4.4.5 as Recapture Exception Accruals. These costs include the costs a taxpayer will incur to de-commission certain types of assets upon reaching the end of their useful life and remediating the site environment. For

example, upon the end of the useful life of a nuclear power plant, the plant must be de-commissioned and environmental remediation will be required as part of the closure process. In order to reflect accurately the economic performance of an investment, accounting standards generally require the present value of anticipated de-commissioning costs to be capitalized and amortized over the life of the relevant asset. Such assets may include oil rigs, a well, a mine, or a power plant.

99. For example, in the natural resource extractive business, future reclamation and other closure costs stemming from ongoing production of a natural resource are generally expensed as the extraction progresses, even though the costs may not be paid until after the mine or well is no longer productive. In some jurisdictions, however, these costs may not be deductible for tax purposes until the operation is de-commissioned or the costs are paid. Some jurisdictions may allow a deduction based on contributions to a trust or similar fund that is created for purposes of funding the future reclamation or closure costs. The amount of these contributions may differ from the amount accrued as an expense in the financial accounts.

100. Inclusive Framework jurisdictions generally allow the deduction of these de-commissioning and remediation costs that are expected to be incurred in the future, thus a commonality exists. De-commissioning, closure, and remediation expenses are also material. For example, significant costs are incurred when a well is abandoned or a mine closed, which could be half a century or more after extraction begins. Including such costs in paragraph (d) of Article 4.4.5 avoids the unintended outcome of effectively denying a GloBE deduction for environmental and other clean up-costs.

101. The rule in paragraph (d) of Article 4.4.5 does not give rise to GloBE policy risks, given the direct connection of the expense with substantive activities in a jurisdiction and the regulatory obligation to clean up site and de-commission assets. Further such timing differences are not prone to manipulation and are certain to reverse over a definite period.

Paragraph (e)

102. Fair value accounting on unrealised gains is included in paragraph (e) of Article 4.4.5 as a Recapture Exception Accrual. Some examples of fair value gains and losses for accounting purposes include increases in value of the investments assets of insurance companies or increases in the value of rights to timber held by a forestry company. Gains on such investments may not brought into account for tax purposes until such amounts have been realised through a sale or other disposition of the asset. The taxation of realised gains and losses is relatively common amongst Inclusive Framework jurisdictions and can give rise to temporary differences, which can often be material to MNE Groups, both in terms of amount and length of deferral. The Recapture Exception Accrual under this paragraph (e) only applies to the extent the fair value accounting is also applied for GloBE purposes. Therefore this paragraph would not apply to the extent the MNE Group had made an election under Article 3.2.5 in relation to such gains.

Paragraph (f)

103. Net gains of foreign currency exchange is taken into account in paragraph (f) of Article 4.4.5. Monetary items such as payables, receivables, and loans denominated in a foreign currency (i.e., different from the functional currency for financial accounting purposes of the Constituent Entity) are translated at the closing rate for accounting purposes, which is the spot exchange rate at the reporting date. These foreign exchange gains and losses are generally recognised in the financial accounting income of a Constituent Entity. Domestic tax laws, however, may not recognise these unrealised foreign exchange gains and losses until a realisation event occurs, such as a repayment of a loan.

Paragraph (g)

104. Insurance reserves are provided for in paragraph (g) of Article 4.4.5 as a Recapture Exception Accrual. Insurance companies generally collect premiums, invest such premiums, and pay claims with the

earnings. When a premium is collected, it is known that some portion of the premium and earnings on such premium will be needed to pay claims, generally in a subsequent period. Inclusive Framework jurisdictions generally allow a deduction with reference to the amount reserved for future claims, thus the full premium received is not subject to CIT. The amount allowed as a tax deduction is typically determined by reference to the amount of reserve requirements set by insurance regulatory agencies, which require insurance companies to hold a certain amount of assets in high-grade, liquid investments to ensure they can pay policyholder claims. Such regulatory capital requirements typically exceed accounting reserves by a significant amount. The difference between these accounting and tax reserves creates temporary differences that may be sustained over long periods, especially in the case of life insurance.

105. Given the commonality of treatment in Inclusive Framework jurisdictions and the materiality of insurance reserve amounts, insurance reserves are treated as Recapture Exception Accruals. These amounts are not prone to manipulation given that the timing rules are governed by regulatory requirements and accounting rules. The amounts are also certain to reverse over a definite period. Absent the rule for insurance reserves, significant distortions would exist with respect to the ETR for insurance companies due to the material timing differences between accounting and tax treatment.

106. The reference to deferred acquisition costs in Article 4.4.5(g) may include the recognition of items relating to in-force contracts (for example, as part of an insurance business acquisition), where the insurer is required to recognise the difference in the fair value of the acquired insurance contracts and insurance obligations assumed on acquisition. This item is commonly known as either value of business acquired, present value of in-force business, acquired value of in-force business, or value of business in-force, and may be recognised or disclosed together with another item, such as deferred acquisition costs, or as a separate item in financial statements for reporting purposes. In either case, to the extent recognised or disclosed, it is intended that Article 4.4.5(g) include such assets and liabilities. As is the case with deferred acquisition costs, this item is also amortised over a definite period, and can lead to material timing differences depending on local tax rules. It is similarly not prone to manipulation as timing of reversal of it is determined by accounting rules and local tax laws. The long-term nature of insurance contracts can also lead to significant timing differences, as a result of differences in tax rules and how insurance contracts are valued under different accounting standards. It is noted that recent changes to accounting standards may change how insurance contracts are measured and recognised and this includes for example how deferred acquisition costs may be referred to and recognised under such standards. Paragraph (g) of Article 4.4.5 shall be interpreted so as to accommodate these changes to the accounting standards as they apply to the items under paragraph (g).

Paragraph (h)

107. Paragraph (h) of Article 4.4.5 provides that deferred tax liabilities associated with gains from the sale of tangible property located in the same jurisdiction as the Constituent Entity that are reinvested in tangible property in the same jurisdiction shall be treated as Recapture Exception Accruals. Some Inclusive Framework jurisdictions permit a taxpayer to benefit from roll-over or deferral relief with respect to gain on the disposition of capital assets if reinvested into a replacement asset within a prescribed time period. The gain is not recognised but is treated as a reduction to the acquisition cost of the new asset, thereby preserving the gain for future taxation. Roll-over or deferral of gain treatment is equivalent to recognising the gain and then allowing an immediate expense of the same amount of the cost of the new asset. Thus, to the extent that the asset is depreciable for accounting purposes, the roll-over or deferral is akin to accelerated depreciation and immediate expensing. However, in the case of land, the temporary difference will not reverse until the land is sold and the gain is not rolled over to a new investment. Such difference is material and common in Inclusive Framework jurisdictions, having characteristics similar to accelerated depreciation. This is because the underlying expenditure is directly connected with investment in tangible assets and the difference will reverse over a definite period. Adherence to financial accounting treatment with respect to such property could lead to unintended outcomes including volatility in GloBE calculations.

Paragraph (i)

108. Paragraph (i) of Article 4.4.5 provides that deferred tax expense resulting from a change in accounting principles with respect to the categories enumerated in paragraphs (a) through (g) also benefit from the Recapture Exception Accrual rule. For example, if a change in accounting principles or policies occurs, as described in IAS 8, in a Fiscal Year that results in additional deferred tax expense being accrued with respect to a previously recorded cost recovery allowance on tangible property, such accrual shall benefit from the Recapture Exception Accrual rule by virtue of the application of this paragraph (i) (IFRS Foundation, 2022^[2]).

Article 4.4.6

109. The Disallowed Accrual rule is set forth in Article 4.4.6 and 4.4.1(b). This rule is intended to prevent accruals of tax with respect to uncertain tax positions and distributions from a Constituent Entity from being included in the Adjusted Covered Taxes amount until actually paid.

110. Amounts accrued with respect to uncertain tax positions are disallowed, given the MNE Group's determination (and possibly its explicit or implicit assertion to the relevant tax authority) that the Taxes are not owed and the high uncertainty with respect to whether such amounts will be paid in a future period. Although the precise criteria may differ under Acceptable Financial Accounting Standards, uncertain tax positions generally result when a Constituent Entity takes a filing position that is not more likely than not to be sustained upon examination. Financial accounting standards require that a reserve is established for such positions. If the filing position is sustained, the reserve is released. Given the nature of such accruals, these amounts may not be treated as Covered Taxes unless and until the amount is actually paid.

111. Taxes levied upon distributions, such as withholding taxes and net basis taxes on dividends received, are generally imposed when an entity makes a distribution to its shareholder(s). Given that the MNE Group generally decides the timing of such distributions between Constituent Entities, it would be inappropriate to provide a current increase to Adjusted Covered Taxes for deferred tax amounts accrued in respect of distribution taxes.

Article 4.4.7

112. Article 4.4.7 provides a compliance simplification option with respect to the Article 4.4.4 recapture rule. This article permits a Constituent Entity to exclude from the Total Deferred Tax Adjustment Amount any deferred tax liability that is not expected to be paid within the time period set forth in Article 4.4.4. This simplification allows for the exclusion of deferred tax liabilities that are almost certain to require recapture, which reduces compliance monitoring such liabilities and recalculating Top-up Tax several years later.

Article 4.5 - The GloBE Loss Election

113. Article 4.5 provides an elective rule to effectively carry GloBE losses forward with a deemed deferred tax asset. When elected, Article 4.5 applies in lieu of the Article 4.4 modified deferred tax accounting rules. Accordingly, Article 4.5 is generally expected to be of greatest utility as a simplification in jurisdictions that do not impose a corporate income tax or impose one at a very low rate given that when the election is made, Article 4.4 no longer applies and temporary differences may result in Top-up Tax. However, the election may be made for any jurisdiction.

Articles 4.5.1 to 4.5.3

114. Article 4.5.1 establishes a deemed deferred tax asset at the Minimum Rate when there is a Net GloBE Loss for a jurisdiction in a Fiscal Year. This GloBE Loss Deferred Tax Asset may be carried forward under Article 4.5.2 and used in any subsequent Fiscal Year in which there is GloBE Income for the jurisdiction under Article 4.5.3. When a GloBE Loss Deferred Tax Asset is used in a subsequent Fiscal Year, the amount of GloBE Loss Deferred Tax Asset is added to Covered Taxes under Article 4.1.2. For example, if a Constituent Entity is located in a country that does not impose a CIT, an election under Article 4.5 would provide a GloBE Loss attribute at the Minimum Rate for economic losses incurred that otherwise would not have a corresponding deferred tax asset due to the lack of a domestic CIT. While Article 4.5 provides for an indefinite carry-forward, domestic law in certain circumstances may limit the practical application of the GloBE Loss DTA after a certain period of time. For example, a jurisdiction may prevent a taxpayer from claiming the benefit of a carry-forward loss unless they can meet certain record keeping and evidential requirements.

Article 4.5.4

115. Article 4.5.4 sets out the transition rule that is applicable if the GloBE Loss Election is subsequently revoked. This article requires that any remaining GloBE Loss Deferred Tax Asset be reduced to zero upon transition. This adjustment is required because when a jurisdiction is transitioned to the modified deferred tax accounting method set out in Article 4.4, the historic deferred tax assets and liabilities will be taken into account as if they had been calculated under Articles 4.4 and 9.1 for the prior Fiscal Years. Allowing the GloBE Loss Deferred Tax Asset to be carried forward into these subsequent Fiscal Years would potentially permit double benefit for losses and other distorted outcomes.

Article 4.5.5

116. Article 4.5.5 provides that the GloBE Loss Election must be filed with the GloBE Information Return of the MNE Group filed for the first Fiscal Year in which the MNE Group has a Constituent Entity located in the jurisdiction for which the election is made and that such election cannot be made for a jurisdiction with an Eligible Distribution Tax System as defined in Article 7.3. Because the GloBE Loss Election can only be filed with the first GloBE Information Return of the MNE Group that includes the jurisdiction for which the election is made, the GloBE Loss Election is an election that may only be made once. This rule is required to limit the applicability of Article 4.5.1 such that it provides a relief mechanism or simplification for jurisdictions where an MNE Group decides that an election is necessary, but also does not allow for manipulation or distortions by shifting into and out of the election over time. Further, permitting a deemed deferred tax asset for losses in jurisdictions with an Eligible Distribution Tax System as defined in Article 7.3 would result in an overstated ETR in such jurisdictions, given that distribution tax is only applicable when positive earnings are distributed.

117. Because the GloBE Loss Deferred Tax Asset is a jurisdictional attribute of the MNE Group, pursuant to Article 6.2.1(f), it does not transfer with a Constituent Entity in the event such entity leaves the MNE Group. Accordingly, when a Constituent Entity has been acquired from another MNE Group, whether such MNE Group has or has not made a GloBE Loss Election will not be relevant or taken into account for purposes of the acquiring MNE Group. Note that to the extent all Constituent Entities in a jurisdiction are transferred, the GloBE Loss Deferred Tax Asset remains with the transferor MNE Group despite the fact that it no longer has Constituent Entities in such jurisdiction. For example, MNE Group 1 has made a GloBE Loss Election with respect to Country A and then sells Constituent Entity Z, which is located in Country A, to MNE Group 2. MNE Group 2 will not acquire any GloBE Loss Deferred Tax Asset with respect to the acquisition of Constituent Entity Z and the GloBE Loss Election made by MNE Group 1 has no impact on MNE Group 2. MNE Group 2 may still elect the GloBE Loss Election for Country A with its first GloBE Information Return that includes Country A if it so desires.

Article 4.5.6

118. Article 4.5.6 provides a special rule for Flow-through Entities that are the UPE of an MNE Group that is made independently of an Article 4.5 election for any jurisdiction. Such entities may make a GloBE Loss Election under Article 4.5 and when the election is made, the GloBE Loss Deferred Tax Asset is calculated for the UPE in accordance with Articles 4.5.1 through 4.5.5. This special GloBE Loss Deferred Tax Asset is calculated solely with reference to the GloBE Loss of the Flow-through Entity after reduction in accordance with Article 7.1.2 to ensure losses that flow through to share-holders are not double counted. This GloBE Loss remains with the Flow-through Entity that is a UPE and can only be used to offset future GloBE Income of such UPE. Accordingly, because other entities are not aggregated with the Flow-through Entity that is a UPE for purposes of calculating the GloBE Loss, this election is made with respect to only the Flow-through Entity that is the UPE. Note that other entities are not aggregated with the Flow-through Entity that is a UPE even if a GloBE Loss Election has been made for the jurisdiction in which the UPE is located.

Article 4.6 - Post-filing Adjustments and Tax Rate Changes

119. Article 4.6 governs adjustments to amounts of Covered Taxes incurred with respect to a jurisdiction after the GloBE Information Return for the period has been filed. An MNE Group's liability for Covered Taxes may increase or decrease for various reasons, such as a change in the amount of income recognised for local tax purposes due to an examination of the tax returns by the tax authority of a jurisdiction or a review of the tax returns by the Entity's management or tax advisers. In addition, the liability for Covered Taxes may increase or decrease due to errors or more accurate estimates of the tax liability after the GloBE Information Return is filed. Increases would normally result in additional tax expense and decreases would normally result in a refund of tax (either in cash to, or as a reduction of another tax liability of, the taxpaying entity or its shareholders) after the GloBE Information Return for the relevant year was filed. These changes to accrued tax expense may have impacted the MNE Group's Top-up Tax liability with respect to a preceding Fiscal Year. In other words, if the final tax liability in a jurisdiction had been correctly determined when the GloBE Information Return was filed, the shareholder may have computed a different ETR and possibly paid more or less Top-up Tax and may have established a larger or smaller deferred tax liability or asset in that Fiscal Year.

Article 4.6.1

120. Article 4.6.1 permits the MNE Group to treat increases to liabilities for Covered Taxes in previous Fiscal Years as current year tax increases for purposes of the GloBE Rules. Similarly, an immaterial decrease for Covered Taxes may be treated as a reduction to Covered Taxes in the current Fiscal Year. While treating such post-filing adjustments to a tax liability in the current year is not as accurate as recalculating the GloBE tax liability or potential GloBE tax liability with respect to the relevant Fiscal Years, it significantly simplifies the computation of Top-up Tax under the GloBE Rules. And these adjustments generally are not the types of adjustments that avoid Top-up Tax liabilities that might have arisen in previous years. Increases to Covered Taxes are only taken into account in the current Fiscal Year. This has the effect that refunds of Top-up Tax paid with respect to prior Fiscal Years will not occur under the operation of Article 4.6.1.

121. In contrast, Article 4.6.1 generally requires a re-computation of the ETR and Top-up Tax for the Fiscal Year to which the tax adjustment relates in the case of a decrease in Covered Taxes. However, a taxpayer may elect to include an immaterial decrease in the current Fiscal Year. An immaterial decrease in Covered Taxes is an aggregate reduction that is less than EUR 1 million in the Adjusted Covered Taxes determined for the jurisdiction for a Fiscal Year. The immateriality of an adjustment is determined for each Fiscal Year by reference to the aggregate increase or decrease in Covered Taxes for each Fiscal Year.

Adjustments for material decreases must be made in respect of the relevant previous Fiscal Year to which the tax adjustment relates because the over-statement of Covered Taxes may have avoided Top-up Tax in that year and simply reducing Covered Taxes in the current year may not effectively recapture the avoided Top-up Tax.

122. This rule is linked to Article 3.2.1(h) which generally provides that a correction of an error in the computation of GloBE Income or Loss for a previous Fiscal Year is taken into account in the current year as additional income or expense. However, under Article 4.6.1, if the error affected taxable income for a jurisdiction and results in a material decrease in Covered Taxes for a previous Fiscal Year, the correction is taken into account in the relevant prior year, subject to the limitations described above. These rules ensure that the GloBE Income or Loss and the Covered Taxes associated with such amount are taken into account in the ETR and Top-up Tax computations for the same Fiscal Year to avoid a distorted result.

123. Thus, when the correction of an error in the determination of a liability for Taxes in a particular jurisdiction results in a material decrease in the tax liability, the MNE Group must do two things to properly apply Article 3.2.1(h) and Article 4.6.1. First, the MNE Group must determine if the error in the tax computation was due to an error in the computation of taxable income and whether there was a corresponding error in the computation of the relevant Constituent Entity's Financial Accounting Net Income or Loss. If so, both the Taxes and the GloBE Income or Loss for the prior year are re-determined. Second, the ETR and Top-up Tax for the prior year must be re-determined based on the re-determined Taxes and GloBE Income or Loss (if also adjusted) in order to determine if there is any Additional Top-up Tax for the jurisdiction pursuant to Article 5.4.1. If that re-determination results in Additional Top-up Tax, such tax is included in the jurisdictional Top-up Tax computation pursuant to Article 5.2 in the Fiscal Year of the re-determination; the MNE Group does not amend its GloBE Information Return or any tax returns filed in association with the GloBE Rules for the year to which the adjustment relates. Corrections that do not arise from a material decrease in tax liability are taken into account in the computation of the ETR and Top-up Tax prospectively pursuant to Article 4.6.1 and Article 3.2.1(h). As discussed in the previous paragraphs, a re-determination may only be carried back to the extent it does not result in a refund of Top-up Tax. To the extent a re-determination would otherwise result in a refund of Top-up Tax, such re-determination is taken into account in the re-determination year (i.e., the current Fiscal Year). Note that under Article 4.6.1 a Filing Constituent Entity may make an Annual Election to treat immaterial decreases in Covered Taxes as an adjustment to Covered Taxes in the re-determination year (i.e., the Fiscal Year in which the adjustment is made).

124. Article 4.6.1 also applies when a domestic tax loss is carried-back to a prior Fiscal Year. When a tax loss is carried-back, a refund of tax for a prior Fiscal Year is issued in the current Fiscal Year. This refund is a decrease to Covered Taxes for a prior Fiscal Year and therefore falls within the scope of Article 4.6.1 as an adjustment to a Constituent Entity's liability for Covered Taxes for a previous Fiscal Year.

125. The refund of Covered Taxes relating to the prior year must be matched with a corresponding adjustment to reflect a carry back of the domestic tax loss that results in outcomes that are consistent with the treatment of carry-forward losses. IF members have agreed that, in the case of a loss carry-back under local law, the domestic tax loss shall be treated as giving rise to a deferred tax asset in the same manner in which it would have under the GloBE Rules had the loss been set up as a carry-forward. Accordingly, unless the refund is immaterial as defined in Article 4.6.1 and the Filing Constituent Entity has elected to take such amount into account in the current Fiscal Year, a deemed deferred tax asset shall be established in the year the domestic tax loss is incurred. The amount of this deferred tax asset shall be the amount that would otherwise have been recognised in the financial accounts had the deferred tax asset been eligible to be carried-forward and capped at an amount equal to the domestic tax loss multiplied by the Minimum Rate. Through the operation of Article 4.4, this recognition of this deferred tax asset will reduce Adjusted Covered Taxes in the Fiscal Year in which the loss is generated. This deferred tax asset shall be treated as reversed, thereby increasing Adjusted Covered Taxes, in the Fiscal Year that the domestic tax loss has been carried-back to, simultaneous with the carry-back of the refund under Article 4.6.1. To the extent the sum of the

deferred tax asset reversal and the tax refund result in a net increase to Covered Taxes for the prior Fiscal Year, the net increase shall be taken into account in the current Fiscal Year under Article 4.6.1. Note to the extent a loss-carry back is taken into account, the rule set forth in Article 4.1.5 continues to apply in the current Fiscal Year. This creation and reversal of the deemed deferred tax asset is the preferred mechanism for recognising the appropriate and necessary adjustments to be made in the recognition of GloBE Income or Loss as it preserves the overall integrity of the deferred tax accounting approach.

126. For example, ABC Co is the only Constituent Entity of a MNE Group in Country A which has a 20% tax rate and permits loss carry-backs. In Year 1, ABC Co reports GloBE Income of 100 and domestic taxable income of the same amount. As a result, in Year 1 Covered Taxes are 20 and the ETR for GloBE purposes is 20%. In Year 2, ABC Co incurs a GloBE Loss and domestic tax loss of (100) and carries it back to Year 1 for Country A tax purposes. A refund of (20) is issued in Year 2 with respect to the Year 1 tax liability. Under Article 4.6.1, the loss results in a deferred tax asset of 15 (the loss of 100 multiplied by the Minimum Rate). Because generation of a deferred tax asset results in a decrease to Adjusted Covered Taxes, in Year 2 Covered Taxes equal (15) and no Top-up Tax arises under Article 4.1.5 since (15) is also the Expected Adjusted Covered Taxes Amount. The refund of (20) is carried back to Year 1 under Article 4.6.1, as is the deferred tax asset of 15. For Year 1 the revised Adjusted Covered Taxes amount for ABC Co is 15 given the refund of (20) and the use of the tax-loss attribute of 15. No additional Top-up Tax results in Year 1 as a result of the carry-back since the GloBE ETR is 15%.

127. Finally, it should be noted that Article 4.6.1 applies when there is a change in the amount of a Taxes determined for a jurisdiction. It does not apply to an adjustment to an MNE Group's liability for Top-up Tax liability as a result of the examination of a tax return that includes Top-up Tax attributable to the charging provisions in Article 2 of the GloBE Rules.

Article 4.6.2

128. Article 4.6.2 provides that when there is a reduction to the applicable domestic tax rate to a rate below the Minimum Rate, such reduction must be taken into account under the rules of Article 4.6.1. This rule ensures that when a domestic tax rate is subsequently reduced the deferred tax expense previously claimed as a Covered Tax is adjusted to the correct value, which is the amount of such tax that will actually be paid upon reversal of the deferred tax liability.

129. For example, in Fiscal Year 1, a Constituent Entity claims 15 of Covered Taxes resulting from a deferred tax liability on 100 of GloBE Income at 15%. In Fiscal Year 2, the jurisdiction reduces its domestic tax rate to 10%. Thus, when the deferred tax liability is ultimately paid, only 10 of tax will be paid (10% ETR). Article 4.6.1 requires when such reduction is material, that the Fiscal Year 1 Top-up Tax must be recomputed. In this case, 5 of Top-up Tax would be due in Fiscal Year 2 owing to the re-computation.

Article 4.6.3

130. Article 4.6.3 provides the rule that is applicable when a deferred tax expense has been taken into account at a rate lower than the Minimum Rate and the applicable tax rate is subsequently increased. In such case, the amount of deferred tax expense that has resulted from the increase is treated as an adjustment to a Constituent Entity's liability for Covered Taxes for a previous Fiscal Year.

131. For example, assume in Fiscal Year 1, a Constituent Entity has 100 of GloBE Income and records a deferred tax liability of 10 (10% ETR) and claims such amount as a Covered Tax. In Fiscal Year 2, the jurisdiction increases its tax rate to 15%. An additional deferred tax liability of 5 is recorded for financial accounting purposes. However, this increase of 5 is disregarded under Article 4.4.1(d) in Fiscal Year 2 and deferred until payment of the tax. In Fiscal Year 3, the tax of 15 is paid and the full deferred tax liability reverses. The incremental 5 of deferred tax liability that reverses, which has not previously been claimed as a Covered Tax because it was disregarded, is taken into account under this Article in Fiscal Year 3

upon payment and is treated as an increase to Covered Taxes through the operation of Article 4.6.1. Note that had the tax rate in this example been 20%, an incremental 10 of Covered Tax would arise upon payment in Year 3, which would consist of the 5 of deferred tax liability that was previously disregarded which is taken into account under this Article, and the incremental 5 of tax liability that reflects tax in excess of the Minimum Rate, which is only taken into account when paid under Article 4.4.1.

Article 4.6.4

132. Article 4.6.4 provides that the ETR and Top-up Tax for a jurisdiction must be recalculated to exclude an amount of current tax expense (i.e., not deferred tax expense) that is more than EUR 1 million, was claimed as Adjusted Covered Tax, and is not paid within three years of the last day of the Fiscal Year in which such amount was claimed as Adjusted Covered Tax.

133. For example in Fiscal Year 1, a Constituent Entity claims 10 of current tax expense as an Adjusted Covered Tax. The Constituent Entity files a local tax return reporting the 10 of tax due, but does not pay such Tax by the end of Fiscal Year 4. The Fiscal Year 1 Top-up Tax must be re-computed under Article 5.4.1 without such 10 of Tax included in the calculation as a result of the non-payment of such Tax.

References

- IFRS Foundation (2022), *International Financial Reporting Standards*, <https://www.ifrs.org/>. [2]
- OECD (2018), *Revenue Statistics 1965-2017 Interpretative Guide, Annex A*, OECD Publishing, OECD, <https://www.oecd.org/tax/tax-policy/oecd-classification-taxes-interpretative-guide.pdf>. [4]
- OECD (2017), *Model Tax Convention on Income and on Capital: Condensed Version 2017*, OECD Publishing, Paris, https://dx.doi.org/10.1787/mtc_cond-2017-en. [1]
- OECD (2015), *Neutralising the Effects of Hybrid Mismatch Arrangements, Action 2 - 2015 Final Report*, OECD/G20 Base Erosion and Profit Shifting Project, OECD Publishing, Paris, <https://dx.doi.org/10.1787/9789264241138-en>. [5]

Notes

¹ The application of Article 4.3.1 is illustrated in the Examples to the Commentary on the Model GloBE Rules under Pillar Two: <https://www.oecd.org/tax/beps/tax-challenges-arising-from-the-digitalisation-of-the-economy-global-anti-base-erosion-model-rules-pillar-two-examples.pdf>.

² The application of Article 4.1.5 is illustrated in the Examples to the Commentary on the Model GloBE Rules under Pillar Two: <https://www.oecd.org/tax/beps/tax-challenges-arising-from-the-digitalisation-of-the-economy-global-anti-base-erosion-model-rules-pillar-two-examples.pdf>.

³ The application of Article 4.3.3 is illustrated in the Examples to the Commentary on the Model GloBE Rules under Pillar Two: <https://www.oecd.org/tax/beps/tax-challenges-arising-from-the-digitalisation-of-the-economy-global-anti-base-erosion-model-rules-pillar-two-examples.pdf>.

⁴ The application of Article 4.4.1 is illustrated in the Examples to the Commentary on the Model GloBE Rules under Pillar Two: <https://www.oecd.org/tax/beps/tax-challenges-arising-from-the-digitalisation-of-the-economy-global-anti-base-erosion-model-rules-pillar-two-examples.pdf>.

5 Computation of Effective Tax Rate and Top-up Tax

1. Chapter 5 contains the computational rules for determining the ETR of jurisdictions in which the MNE operates and for determining the Top-up Tax for a Low-Tax Jurisdiction. The calculation of Top-up Tax for a Low Tax Jurisdiction also includes rules for determining the amount of income that is excluded from the GloBE Rules by virtue of the Substance-based Income Exclusion. Chapter 5 also includes a De Minimis Exclusion for the Constituent Entities located in the same jurisdiction when their aggregated revenue and income does not exceed certain thresholds.

Article 5.1 - Determination of Effective Tax Rate

2. The ETR computation in Article 5.1 is a central element of the GloBE Rules. It is used both to determine whether in a Fiscal Year, the MNE Group is subject to a minimum level of tax on its income arising in a particular jurisdiction and, if the jurisdiction's ETR is below the Minimum Rate (i.e. the jurisdiction is a Low-Tax Jurisdiction in respect of the MNE Group in that Fiscal Year). ETRs are generally computed on a jurisdictional basis. Stateless Constituent Entities are treated as being the only Constituent Entity in a jurisdiction. Certain Investment Entities and Insurance Investment Entities generally compute their ETR on a stand-alone basis under Article 7.4, but if the MNE Group has two Investment Entities in the same jurisdiction, their ETR is computed by taking into account Covered Taxes and GloBE Income or Loss of both entities. Similarly, if the MNE Group has a Minority-Owned Subgroup, a separate ETR computation is necessary for the Minority-Owned Constituent Entities located in a jurisdiction separate from the calculation made for the other Constituent Entities. Thus, in some cases, an MNE Group will compute an ETR for a jurisdiction that is relevant for ordinary Constituent Entities located in the jurisdiction, another ETR that is relevant for Investment Entities or Insurance Investment Entities located in the jurisdiction, and another ETR that is relevant for Minority-Owned Constituent Entities of a Minority-Owned Subgroup. The information necessary to compute the ETR of each jurisdiction will be included in the GloBE Information Return in accordance with the requirements of Article 8.1.

Article 5.1.1

3. Article 5.1.1 sets out the formula for computing the jurisdictional ETR. The ETR for a jurisdiction is equal to the sum of the Adjusted Covered Taxes of each Constituent Entity located in the jurisdiction for the Fiscal Year divided by the Net GloBE Income of the jurisdiction. The result is expressed as a percentage rounded to the fourth decimal place (e.g. 14.12346% = 14.1235%) for purposes of the GloBE Rules. An ETR is not computed for a jurisdiction that has a Net GloBE Loss for the Fiscal Year. The sum of the Adjusted Covered Taxes of each Constituent Entity means the sum of all of the Adjusted Covered Taxes determined under the rules of Chapter 4 for the Constituent Entities that are located in the same jurisdiction. Likewise, the Net GloBE Income or Loss of a jurisdiction is determined by aggregating all of the GloBE Income or Loss of all Constituent Entities located in the same jurisdiction. Consequently, the

taxes and income attributable to Ownership Interests held by persons that are not Group Entities are taken into account in the ETR calculation.

4. A jurisdictional blending calculation based on the aggregate income and taxes of all Constituent Entities in the same MNE Group means that when the Parent Entity applying the IIR is not the UPE, the ETR of a jurisdiction is not computed solely by reference to the Constituent Entities owned by that Parent Entity. Rather the ETR is computed by reference to all the Constituent Entities of the MNE Group located in that jurisdiction. The implication of determining the ETR based on a group-wide average ETR for the jurisdiction is that there may be cases where allocable Top-up Tax arises in respect of an Entity that would not be an LTCE if the ETR for the jurisdiction were computed on a single-entity basis or solely on the basis of taxes and income attributable to a Parent Entity's Ownership Interests in the Constituent Entities located in the jurisdiction. On the other hand, an Entity that would have been an LTCE on a stand-alone basis may not be an LTCE due to taxes paid or losses incurred by other Constituent Entities located in the jurisdiction. This approach to jurisdictional blending avoids risks that would otherwise arise to the integrity of the rules from shifting income and taxes between Constituent Entities located in the same jurisdiction and avoids potential distortions caused by particular features of the domestic tax system (such as loss-surrender and tax consolidation mechanisms). It also simplifies the mechanic for the attribution and allocation of Top-up Taxes under the IIR and UTPR.

5. There are three specific exceptions to this jurisdictional ETR computation.

6. The first exception is for Investment Entities and Insurance Investment Entities. Pursuant to Article 5.1.3, discussed below, income and taxes of Investment Entities and Insurance Investment Entities located in a jurisdiction are excluded from the ETR computation for that jurisdiction. Special ETR computation rules are provided in Article 7.4 for such Investment Entities and Insurance Investment Entities.

7. The second exception applies to Constituent Entities in which the UPE holds 30% or less of the Ownership Interests but nonetheless has a Controlling Interest in the Entity. In those cases, the rules in Article 5.6 require separate ETR computations for those Constituent Entities if they are located in a jurisdiction with ordinary Constituent Entities and the ETR computations for the Minority-Owned Constituent Entities make certain adjustments for income and taxes attributable to non-controlling interests. Those rules are further discussed in the Commentary to Article 5.6.

8. Finally, the last sentence of Article 5.1.1 provides a special rule under which each Stateless Constituent Entity is treated as a single Constituent Entity located in a separate jurisdiction for purposes of Chapter 5. This rule adapts the general rules for computing the jurisdictional ETR to Stateless Constituent Entities. The GloBE Income or Loss and Adjusted Covered Taxes of a Stateless Constituent Entity, which go into the ETR computation, are determined in accordance with Chapters 3 and 4

9. Because these exceptions arise only in a minority of cases, they are not specifically mentioned in the Commentary to each Article in Chapter 5 where they may apply. However, when the exception applies the Commentary should be interpreted in light of and consistent with the exception.

Article 5.1.2

10. Article 5.1.2 sets out the formula for computing the Net GloBE Income of a jurisdiction. The formula defines the Net GloBE Income of a jurisdiction as the positive amount, if any, obtained by subtracting GloBE Losses for the Fiscal Year of all Constituent Entities located in a jurisdiction from the GloBE Income for the Fiscal Year of all those Constituent Entities. The calculation does not include the GloBE Income or Losses of an Investment Entity, as noted in Article 5.1.3.

11. If the GloBE Losses of the Constituent Entities equal or exceed GloBE Income of the Constituent Entities located in that jurisdiction, there is no Net GloBE Income under Article 5.1.2, and therefore, there can be no Top-up Tax computed under Article 5.2 with respect to the jurisdiction. Consequently, the ETR

for the jurisdiction need not be computed. Note, however, there may be cases in which Top-up Tax is determined under Article 4.1.5 for a jurisdiction that has a Net GloBE Loss. See the Commentary to Article 4.1.5.

Article 5.1.3

12. As noted above, Article 5.1.3 provides that the Adjusted Covered Taxes and GloBE Income or Loss of Investment Entities located in a jurisdiction are excluded from the jurisdictional ETR computation. The exception in Article 5.1.3 extends also to Insurance Investment Entities. This exclusion is necessary because an Investment Entity or an Insurance Investment Entities that is controlled by the MNE Group can be included in the GloBE Rules, but such an Investment Entity or Insurance Investment Entity would be subject to the special rules in Chapter 7. (The scope of the Excluded Entity definition in Article 1.5 applies only to an Investment Entity that is the UPE or that satisfies the requirements of Article 1.5.2) Article 5.1.3 helps to maintain the tax neutrality of controlled Investment Entities under the GloBE Rules and facilitates the application of the special rules in Chapter 7 to income earned by an MNE Group through an Investment Entity or an Insurance Investment Entities. When necessary, the ETR of Investment Entities and Insurance Investment Entities is computed separately pursuant to Article 7.4.

13. The rule in Article 5.1.3 is not relevant in the case of an Investment Entity or an Insurance Investment Entity that is a Tax Transparent Entity because its income and taxes are allocated to Constituent Entity-owners, Permanent Establishments, or unrelated persons under Article 3.5.3 and Article 4.3.2.

Article 5.2 - Top-up Tax

14. Article 5.2 sets out the rules for determining the amount of Top-up Tax that is due with respect to a jurisdiction and how such Top-up Tax is allocated amongst the LTCEs located in that jurisdiction. The rules in Article 5.2.1 first determine the Top-up Tax Percentage, which is the rate needed to bring the tax rate on the Excess Profit for the jurisdiction up to the Minimum Rate. Article 5.2.2 then determines the amount of Excess Profit that is subject to the Top-up Tax Percentage, and Article 5.2.3 uses these two computations to compute the amount of Top-up Tax that arises with respect to an MNE's operations in that jurisdiction. Once the Top-up Tax amount has been computed, Article 5.2.4 operates to allocate the Top-up Tax to Constituent Entities located in the jurisdiction. Lastly, Article 5.2.5 provides a special rule for dealing with Top-up Tax determined under Article 5.4.1 for a year in which there is no Net GloBE Income for the jurisdiction.

Article 5.2.1

15. Article 5.2.1 sets out the formula for computing the Top-up Tax Percentage for each jurisdiction. The Top-up Tax Percentage for a jurisdiction is equal to the percentage point excess of the Minimum Rate over the ETR determined for the jurisdiction under Article 5.1 for the Fiscal Year. For this purpose, the percentage point excess of the Minimum Rate over the ETR is the positive difference, if any, between the Minimum Rate and the ETR of the jurisdiction, expressed as a percentage. For instance, assume a jurisdiction where the ETR is 8.18%, the Top-up Tax Percentage is equal to 6.82% (= 15% - 8.18%).

16. For purposes of the GloBE Rules, a jurisdiction is considered a Low-Tax Jurisdiction in respect of the MNE Group and the Constituent Entities located in the jurisdiction are considered LTCEs when the ETR is below the Minimum Rate. If the ETR equals or exceeds the Minimum Rate, there is no Top-up Tax Percentage for the jurisdiction and none of the Constituent Entities located in the jurisdiction will be considered LTCEs.

Article 5.2.2

17. Article 5.2.2 sets out the formula for determining the Excess Profit for a jurisdiction. The Excess Profit is the amount of profit, determined on a jurisdictional basis, upon which the Top-up Tax is levied. The Excess Profit for the jurisdiction is the amount remaining after applying a Substance-based Income Exclusion (as determined under Article 5.3) for the jurisdiction. Where a taxpayer elects not to apply the Substance-based Income Exclusion, the Excess profit is equal to the Net GloBE Income for the jurisdiction. If the Substance-based Income Exclusion for the jurisdiction equals or exceeds the Net GloBE Income for the jurisdiction, there will be no Excess Profit, and thus no Top-up Tax computed for that year unless there is Additional Current Top-up Tax for that Fiscal Year.

18. The Excess Profit formula incorporates the Substance-based Income Exclusion into the jurisdictional blending model. The Substance-based Income Exclusion for the jurisdiction is the aggregation of the exclusions computed for each Constituent Entity located in the jurisdiction. The amount computed for a Constituent Entity is not limited by the GloBE Income of the Entity. Thus, if a Constituent Entity incurs a loss or has very little profit for the Fiscal Year, its Substance-based Income Exclusion may nonetheless exclude the profit of other Constituent Entities in the jurisdiction from the reach of the Top-up Tax.

Article 5.2.3

19. Article 5.2.3 provides the formula for computing the Jurisdictional Top-up Tax. This formula is built on the Top-up Tax Percentage computed under Article 5.2.1 and the Excess Profit computed under Article 5.2.2. The Top-up Tax Percentage is multiplied by the Excess Profit of the jurisdiction for the Fiscal Year. The product of that computation is then increased by any Additional Current Top-up Tax computed under Article 4.1.5 and Article 5.4.1 for the Fiscal Year and reduced (but not below zero) by any Qualified Domestic Minimum Top-up Tax in order to arrive at the Jurisdictional Top-up Tax. As explained in more detail in the Commentary to Article 5.4, the Additional Current Top-up Tax is an amount of Top-up Tax added to the current year that is attributable to certain re-calculations of the Top-up Tax in previous years. The amount of Additional Current Top-up Tax for a jurisdiction must be computed before any reduction by a Qualified Domestic Minimum Top-up Tax. However, if the Top-up Tax for the jurisdiction is zero due to the application of a Qualified Domestic Minimum Top-up Tax, Top-up Tax does not need to be allocated among Constituent Entities in the jurisdiction under Articles 5.2.4, 5.2.5, or 5.4.3.

20. Any tax payable pursuant to a Qualified Domestic Minimum Top-up Tax is taken into account at this point in the computation so as to give full credit in the GloBE Top-up Tax computation. Thus, tax payable pursuant to a Qualified Domestic Minimum Top-up Tax can offset the Top-up Tax (including any Additional Current Top-up Tax calculated for the Fiscal Year) that would have been computed under Article 5.2.3 for the Fiscal Year absent the Qualified Domestic Minimum Top-up Tax. A jurisdiction is not required to adopt a Qualified Domestic Minimum Top-up Tax under the common approach. But if it does, the Qualified Domestic Minimum Top-up Tax will in many cases reduce the Top-up Tax to nil under Article 5.2.3. The amount of a Qualified Domestic Minimum Top-up Tax may be different from that determined under the GloBE Rules as a result of different applicable accounting standards as permitted by the definition of Qualified Domestic Minimum Top-up Tax in Article 10.1. This difference may result in an amount of Qualified Domestic Minimum Top-up Tax in excess of the amount of Top-up Tax that would otherwise be computed under Article 5.2.3. The amount of any excess, however, will not reduce the Top-up Tax under the GloBE Rules below zero or result in a refund of, or credit against future, Top-up Tax under the GloBE Rules.

Article 5.2.4

21. Article 5.2.4 allocates the Jurisdictional Top-up Tax computed for a Low-Tax Jurisdiction among the Constituent Entities in the jurisdiction. Because the Jurisdictional Top-up Tax is computed in Article 5.2.3 by reference to the Net GloBE Income, it is allocated only to Constituent Entities that have GloBE Income for the Fiscal Year; none is allocated to Constituent Entities with GloBE Losses. The allocation only to Constituent Entities that have GloBE Income is accomplished through an allocation key based on the ratio of each Constituent Entity's GloBE Income for the Fiscal Year to the sum of the GloBE Income of all Constituent Entities located in the jurisdiction that have GloBE Income for the Fiscal Year.

22. Although Top-up Tax is computed on a jurisdictional basis, the IIR charging provisions in Chapter 2 are based on the Parent Entity's rights to the profits of specific LTCEs. The allocation of Top-up Tax among LTCEs under Article 5.2.4 facilitates the application of the IIR by Parent Entities other than the UPE. POPEs and some Intermediate Parent Entities do not have the same Ownership Interests in the profits of an LTCE as the UPE. If there are multiple LTCEs in the Low-Tax Jurisdiction, the Top-up Tax of each LTCE would be allocable in different proportions to Parent Entities with different Ownership Interests percentages in the various LTCEs. If, however, the UPE is applying an IIR and all of the LTCEs are wholly-owned, all of the Top-up Tax computed for the jurisdiction is allocable to the UPE under Chapter 2 and therefore, as a practical matter, the UPE does not need to make the allocation among LTCEs under Article 5.2.4. The allocation of Top-up Tax to specific LTCEs also facilitates application of the UTPR, particularly in cases where part of an LTCE's Top-up Tax is subject to an IIR and the remainder is subject to the UTPR.

Article 5.2.5

23. Article 5.2.5 addresses situations where Additional Current Top-up Tax is computed for a jurisdiction under Article 5.4.1 and the jurisdiction does not have Net GloBE Income for the Fiscal Year. As a matter of convenience, Article 5.2.4 generally allocates Additional Current Top-up Tax computed under Article 5.4.1 along with Top-up Tax computed for the Fiscal Year among LTCEs under Article 5.2.4 based on the GloBE Income of such Entities. The charging provisions under Article 2.2 allocate Top-up Tax from LTCEs to Parent Entities based on the Parent Entity's allocable share of their GloBE Income. Where a jurisdiction lacks Net GloBE Income in the current year, it is more appropriate to allocate Additional Current Top-up Tax based on the GloBE Income of the Constituent Entities in the relevant previous years because all of the Top-up Tax was calculated by reference to the Net GloBE Income of those years. Where the UPE is subject to an IIR, the LTCEs are wholly-owned, and there is no POPE in the MNE Group, allocation of Top-up Tax based on the facts of different Fiscal Years will make no difference in the end because all of the Top-up Tax of all Constituent Entities in a jurisdiction would be allocated to the UPE.

24. Additional Current Top-up Tax attributable to the operation of Article 4.1.5 is not allocated pursuant to Article 5.2.5. Such Additional Current Top-up Tax is allocated separately under Article 5.4.3.

Article 5.3 - Substance-based Income Exclusion

25. The policy rationale behind a formulaic, substance-based carve-out, based on payroll and tangible assets is to exclude a fixed return for substantive activities within a jurisdiction from the application of the GloBE Rules. The use of Payroll and Tangible Assets as indicators of substantive activities is justified because these factors are generally expected to be less mobile and less likely to lead to tax-induced distortions. Conceptually, excluding a fixed return from substantive activities focuses GloBE on "excess income", such as intangible-related income, which is most susceptible to BEPS risks.

26. The Substance-based Income Exclusion set out in Article 5.3 only affects those MNE Groups with operations in jurisdictions that are taxed below the Minimum Rate. Further, because the potential benefit

is limited to a routine return and considering the computational rules of the Top-up Tax, the design avoids any tax induced distortions of investment decisions.

Article 5.3.1

27. Article 5.3.1 explains the role of the Substance-based Income Exclusion in the computation of Excess Profits and Top-up Tax under Article 5.2. The exclusion is subtracted from the Net GloBE Income in the jurisdiction in order to arrive at a measure of Excess Profit. If the exclusion determined for a Fiscal Year exceeds the Net GloBE Income of the jurisdiction for that year, there will be no Excess Profit, and thus no Top-up Tax computed for that year unless there is Additional Current Top-up Tax for that Fiscal Year. The excess of the Substance-based Income Exclusion over the Net GloBE Income of the jurisdiction for a Fiscal Year cannot be carried forward or backward to reduce the Net GloBE Income of another Fiscal Year.

28. The Substance-based Income Exclusion applies by default to each jurisdiction in which the MNE Group operates. However, an MNE Group is permitted to annually elect out of the requirement to apply the exclusion on a jurisdiction-by-jurisdiction basis. The election not to apply the exclusion is provided because some MNE Groups may consider that the burden of computing the amount of the exclusion for a particular jurisdiction outweighs the potential benefits of the exclusion in that jurisdiction.

29. The election not to apply the exclusion is made by the Filing Constituent Entity and it is made on a jurisdiction-by-jurisdiction basis. The Filing Constituent Entity makes the election by filing a GloBE Information Return that computes Excess Profits consistent with the election, i.e. by not subtracting an exclusion amount from the Net GloBE Income of the jurisdiction. An explicit affirmative statement that the election is being made for a jurisdiction is not necessary. An election not to apply the exclusion for a Fiscal Year cannot be revoked after a GloBE Information Return for that Fiscal Year has been filed consistent with the election. However, the MNE Group is not bound to make the election for the same jurisdiction in any subsequent Fiscal Year. Thus, an MNE Group that elects not to apply the Substance-based Income Exclusion for a jurisdiction in one year may apply the exclusion in the following Fiscal Year.

Article 5.3.2

30. Article 5.3.2 provides that the Substance-based Income Exclusion is comprised of two components – the payroll carve-out and the tangible asset carve-out. The Commentary below elaborates on these components, starting with the payroll carve-out and then turning to the tangible asset carve-out.

Article 5.3.3

31. The payroll carve-out subtracts from the Net GloBE Income of a jurisdiction a fixed return on activities performed in that jurisdiction calculated by reference to the Constituent Entity's employment costs. The payroll carve-out design recognises a Constituent Entity's payroll expense as an appropriate proxy for substantive activities carried out by employees of the MNE Group in the relevant jurisdiction. In applying the payroll carve-out, it is necessary to identify relevant employees (Eligible Employees), the location of those employees, and the relevant payroll expenses of those Eligible Employees (Eligible Payroll Costs).

Eligible Employees

32. For the purposes of the payroll carve-out, Article 10.1 defines Eligible Employees as employees, including part-time employees, of a Constituent Entity and independent contractors participating in the ordinary operating activities of the MNE Group under the direction and control of the MNE Group. This definition is consistent with CbCR and avoids what would otherwise be a difficult line-drawing exercise of

distinguishing an employee from an independent contractor (OECD, 2015^[6]).¹ For purposes of the payroll carve-out, independent contractors include only natural persons and may include natural persons who are employed by a staffing or employment company but whose daily activities are performed under the direction and control of the MNE Group. Independent contractors do not include employees of a corporate contractor providing goods or services to the Constituent Entity.

Jurisdiction where employee carries out its activities

33. The payroll carve-out is computed on a jurisdictional basis and is based on the Eligible Payroll Costs of Eligible Employees that perform activities in the jurisdiction where the Constituent Entity employer is located. Employees will generally perform their activity in the jurisdiction where the Constituent Entity employer is located (employer's jurisdiction). However, in certain cases the employee may also perform work for their employer outside the employer's jurisdiction. Consideration will be given to the development of Agreed Administrative Guidance as part of the GloBE Implementation Framework to address those cases where the employee performs part of its activities in another jurisdiction and for those employees that perform their activity in multiple jurisdictions.

Eligible Payroll Costs

34. The payroll carve-out takes a broad approach to determining Eligible Payroll Costs based on a general test of whether the expenditure of the employer gives rise to a direct and separate personal benefit to the employee. Article 10.1 defines a Constituent Entity's Eligible Payroll Costs to include expenditures for salaries and wages as well as for other employee benefits or remuneration such as medical insurance, payments to a Pension Fund or other retirement benefits, bonuses and allowances payable to Eligible Employees, and stock-based compensation. Eligible Payroll Costs also includes payroll taxes (or other employee expense-related taxes such as fringe benefits taxes), as well as employer social security contributions.

35. Consistent with the broad approach for determining Eligible Payroll Costs, the payroll carve-out is based on the total amount of the payroll expenditures accrued in the financial accounts for the Fiscal Year, except for payroll expenses capitalised into the carrying value of Eligible Tangible Assets subject to the Tangible Assets carve-out. Payroll expenditures capitalized into Eligible Tangible Assets will be taken into account in the Tangible Assets carve-out. Payroll expenditures that are capitalised to other Tangible Assets, including inventory, are included in Eligible Payroll Costs.

36. The payroll carve-out computation shall not include the payroll costs attributable to a Constituent Entity's International Shipping Income and Qualified Ancillary International Shipping Income under Article 3.3. Payroll costs attributable to a Constituent Entity's excess income over the cap for Qualified Ancillary International Shipping Income under Article 3.3.4 are included in the payroll carve-out computation (given that such excess income would not qualify for the exclusion from the GloBE Rules, allowing the associated Substance-based Income Exclusion is warranted). The amount of payroll cost attributable to International Shipping Income and to Qualified Ancillary International Shipping Income that is excluded shall be determined under the same principles set out in Article 3.3.5. The payroll which is directly allocable to the International Shipping Income and Qualified Ancillary International Shipping that is within the cap under Article 3.3.4 shall be excluded. Payroll expense that cannot be directly allocated shall be allocated between a Constituent Entity's International Shipping Income, Qualified Ancillary International Shipping Income, and other income on a formulaic basis in proportion to its revenues from international shipping over its total revenues.

Article 5.3.4

37. The tangible asset carve-out subtracts from the Net GloBE Income of a jurisdiction a fixed return on the carrying value of Eligible Tangible Assets located in that jurisdiction. Eligible Tangible Assets include the carrying value of property, plant and equipment, natural resources, and a lessee's right-of-use assets that are located in the jurisdiction in which the Constituent Entity is located. Including a broad range of tangible assets in the carve-out base recognises that all such assets are indicative of substantive activities. Moreover, it helps to level the playing field across industries that use varying types of tangible assets in their business. Including leased tangible assets neutralises the difference between owning and leasing assets and recognises that the business decision to own or lease typically has no bearing on the intensity of substantive activities. The section below provides more details on each category of included tangible assets and excluded assets.

Jurisdiction where asset is located

38. The tangible asset carve-out requires that the tangible assets are located in the same jurisdiction as the Constituent Entity that owns them or, in the situation where the tangible asset falls into categories (c) or (d), in the same jurisdiction as the Constituent Entity that holds the right-of-use of the asset. It is expected that, in most cases, the tangible asset will be located in the same jurisdiction as the Constituent Entity that owns or leases the asset. However, under specific circumstances, the nature of the asset and the way it is used may be such that it is not located in any jurisdiction or is located in multiple jurisdictions (e.g. an aircraft of an international airline) at different times during the Fiscal Year. Consideration will be given to the development of Agreed Administrative Guidance as part of the GloBE Implementation Framework to address those cases.

Paragraph (a) - Property, plant and equipment

39. Property, plant and equipment are tangible assets that are held for use in the production or supply of goods or services or for administrative purposes and are expected to be used during more than one period. Assets in this category include: buildings, machinery, computers and other office equipment, motor vehicles, furniture and fixtures, and land.

Paragraph (b) - Natural resources

40. Natural resources include oil and gas deposits, timber tracts and mineral deposits. These assets are accounted for similarly to depreciable property, plant and equipment. That is, natural resources are initially recognised at cost, including acquisition, exploration-related, and restoration costs. After initial recognition, the asset is carried at its cost less any accumulated depletion and any accumulated impairment losses, i.e., the cost model.² Depletion allocates the cost of natural resources to the extracted mineral or severed timber and has a number of similarities to depreciation accounting. Because the usefulness of a natural resource is generally directly related to the amount of resources extracted, the units of production method is widely used to calculate depletion. Service life is therefore the estimated amount of resources to be extracted, e.g., tons of minerals or barrels of oil.

Paragraph (c) - Right-of-use Tangible Assets

41. A carve-out based on the ownership of tangible assets would lead to a difference between owning and leasing assets. In order to avoid this distortion, the carve-out includes the carrying value of a leased tangible asset, including buildings and land, in the same way as property, plant and equipment owned by the Constituent Entity.

42. In a lease arrangement a lessee recognises a "right-of-use" asset on its balance sheet representing its right to use the underlying asset and a lease liability representing its obligation to make

lease payments. A right-of-use asset may arise in connection with the use of an asset owned by the government or a private party. A lessee accounts for right-of-use assets similarly to an owner of property, plant and equipment. Specifically, a lessee initially recognises right-of-use assets based on the present value of the lease payments, and subsequently recognises depreciation and impairment losses i.e., the cost model.³ For purposes of Article 5.3.4, a right-of-use asset in respect of tangible asset will be treated the same as ownership of the tangible asset notwithstanding variations in the treatment of the asset in the financial accounts.

43. The lessor of an asset is not allowed a carve-out in respect of the carrying value of that asset. This rule reflects the fact that the lessor is not actively using the underlying asset to earn income. It is therefore not a reliable measure of substantive activities of the lessor.

Paragraph (d) - Licence or similar arrangements from the government to use immovable property or exploit natural resources

44. Licences and similar arrangements from the government, such as leases or concessions, for the use of immovable property or the exploitation of natural resources are included in Eligible Tangible Assets where the use of the property entails significant investment in tangible property. These arrangements provide rights similar to right-of-use tangible assets. Accordingly, to the extent they represent rights to use immovable property or to exploit natural resources owned by a government, these assets are included in the definition of Eligible Tangible Assets for purposes of the tangible asset carve-out, irrespective of whether they are recorded, or treated, as an intangible asset in the financial accounts or under the financial accounting standard used in the Consolidated Financial Statements. However, to the extent a Constituent Entity treats the right to charge tolls or fees in connection with operation of the property that underlies the licence or similar right as an asset separate from the right to use the immovable property, for example as a separate service contract, such asset is not included in Eligible Tangible Assets.

45. National or sub-national governments may grant rights to a Constituent Entity to use immovable property owned by the government in connection with the Entity's business or to exploit natural resources that are owned by the government. This may occur, for example, in situations where the government may not be permitted by law to sell the property or those resources to private persons or businesses, although it is not limited to these situations. This is often the case in connection with infrastructure assets. For example, a government may engage a Constituent Entity to build infrastructure assets, such as a road, a bridge, a hospital, or an airport, that will be owned by the government when complete and grant the Constituent Entity a concession licence to use those the infrastructure assets in connection with the Constituent Entity's toll road or bridge, hospital, or airport business for a period of years. The property that underlies the infrastructure concession licence is already owned by the government or will be owned by the government once it is constructed or improved. Similarly, a government may allow a Constituent Entity to extract and sell natural resources, such as minerals, timber, or oil and gas from a deposit, forest or reserve, that are owned by the government, and these rights are included in the Eligible Tangible Assets. The land under which the deposit, forest or reserve lies will continue to be owned by the government after the rights to exploit the natural resource expire. Finally, a licence or similar arrangement from the government for the use of part of a communications spectrum is a right to use immovable property included in the scope of Eligible Tangible Assets. In all of these cases, the Constituent Entity incurs costs to acquire the licence or similar right and will need to make significant investments in tangible assets to make productive use of the acquired rights. Accordingly, in such cases, the infrastructure concession licence, mineral rights, and licence to use a communications spectrum will be considered Eligible Tangible Assets, irrespective of whether they are recorded, or treated as, an intangible asset in the financial accounts or under the financial accounting standard used in the Consolidated Financial Statements. However, if the holder of the licence or arrangement from the government does not use the right in its own business and does not make significant investments in tangible property to exploit the rights granted, but instead re-

licences the rights to another person or Entity, the licence or similar arrangement is not an Eligible Tangible Asset.

Excluded assets

46. The tangible asset carve-out computation excludes the carrying value of property (including land or buildings) held for investment, sale, or lease. While the carve-out generally seeks to recognise a broad range of tangible assets, an MNE Group should not be allowed to generate a larger carve-out by purchasing investment property in a jurisdiction. This risk is particularly relevant as it relates to buildings and land, which are commonly held as investments. To neutralise this risk, buildings and land that are held to earn rental income or for capital appreciation (or both), are excluded from the carve-out. The carve-out will still, however, take into account owner-occupied property that is directly or indirectly used in production or supply of goods and services. This rule is not expected to materially increase complexity or compliance costs because many accounting standards already require that such assets be identified and accounted for separately. For example, in the case of IFRS, investment properties are separately accounted for under IAS 40 – Investment Property (IFRS Foundation, 2022^[2]).

47. Similarly, an MNE Group should not be allowed to generate a larger carve-out via tangible assets whose carrying cost will be recovered principally through a sale transaction instead of through continuing use in the business. Since such assets are held for sale, not use, they are a poor proxy for substantive activities. Consequently, assets held for sale are excluded from the carve-out. In order to be considered held for sale, the asset must be available for immediate sale in its present condition subject only to terms that are usual and customary for sales of such assets and its sale must be highly probable. This rule is also not expected to materially increase complexity or compliance costs because many accounting standards already require that such assets be identified and accounted for separately. For example, in the case of IFRS, assets held for sale are separately accounted for under IFRS 5 – Non-current Assets Held for Sale and Discounting Operations (IFRS Foundation, 2022^[2]).

48. The tangible asset carve-out computation shall not include the carrying value of tangible assets attributable to the generation of a Constituent Entity's International Shipping Income and Qualified Ancillary International Shipping Income that is within the cap under Article 3.3.4 (i.e. ships and other maritime equipment and infrastructure). The carrying value of tangible assets used in the generation of Qualified Ancillary International Shipping Income must be excluded in proportion to the excluded income, i.e. based on the ratio of Qualified Ancillary International Shipping Income within the cap to the total Qualified Ancillary International Shipping Income.

Article 5.3.5

49. Article 5.3.5 sets out the rules for determining the carrying value of Eligible Tangible Assets for purposes of the tangible asset carve-out. The Article requires the MNE Group to determine the carrying value for purposes of the carve-out in conformity with the carrying value of the asset as recorded for purposes of preparing the Consolidated Financial Statements (i.e. after taking into account purchase accounting adjustments and elimination adjustments attributable to inter-company sales). The carrying value of each asset for purposes of the carve-out is the average of the beginning and end of year carrying values. Thus, if an asset is acquired or disposed during the Fiscal Year, its carrying value at the beginning or end of the Fiscal Year will be zero. Because the zero carrying value is included in the computation of the average, the carve-out for assets acquired or disposed during the year will be based on half of the carrying value of asset at the end or beginning of the year. The consequence of taking into account purchase accounting adjustments in respect of Eligible Tangible Assets and ignoring inter-company sales adjustments is that the tangible asset carve-out is based on the cost of acquiring the assets from unrelated persons and reflects the MNE Group's actual investment in the relevant assets. Failure to include purchase

accounting adjustments would understate the actual investment and including inter-company sales could overstate or understate the actual investment.

50. For financial accounting purposes, assets included in property, plant and equipment generally are initially recognised on the financial accounting balance sheet at their acquisition cost, including their purchase price and any costs directly attributable to bringing the asset to the location and condition necessary for it to be capable of operating in the manner intended by management. After initial recognition as an asset, an item of property, plant and equipment is carried on the balance sheet at its cost less any accumulated depreciation and any accumulated impairment losses (referred to as the “cost model”). Depreciation refers to the systematic allocation of the cost of an asset, less its residual or “salvage” value, over its useful life. An impairment loss is the amount by which the carrying amount of an asset exceeds its recoverable amount. Natural resources are also accounted for similarly to property, plant and equipment, except that the carrying value of natural resources is reduced by an allowance for depletion rather than depreciation.

51. Land is not subject to an allowance for depreciation. However, like property, plant and equipment, land is tested for impairment. In the case of land, an impairment could arise when, for example, the area where the land is located experiences a natural disaster such as flooding, an earthquake or a tornado. If the land is in fact impaired, an impairment loss is recognised and the carrying value of the land is reduced.

52. As described in the Commentary to Article 3.2.1(d), certain accounting standards allow depreciation of property, plant and equipment based on the revaluation model. See, for example IAS 16 (IFRS Foundation, 2022^[21]). Under the revaluation model, assets are periodically re-valued and their carrying value increased or decreased accordingly in the financial accounts. Thus, such assets may be reflected in the financial accounts at a value above their acquisition cost. Absent a corrective measure the revaluation model would impact the quantum of the carve-out because carrying value of the assets is determined based on the revalued amount. This result is not appropriate because revaluation increases/decreases have no connection to substantive activities. Therefore, to eliminate the effect of the revaluation model for purposes of the carve-out, any increase in the value of an asset and any subsequent incremental increase in depreciation resulting from revaluation increases are disregarded. The result of this rule is that the carrying value of the asset never exceeds what it would have been without the revaluation. Such a result recognises that revaluation increases have no connection to incremental substantive activities. It also eliminates a key difference across accounting standards: those that allow the revaluation model and those that do not.

Article 5.3.6

53. Article 5.3.6 provides rules applicable to the computation of the amount of Eligible Payroll Costs and Eligible Tangible Assets of a PE that is a Constituent Entity. This provision states that the Eligible Payroll Costs and the Eligible Tangible Assets of the PE are those included in its separate financial accounts.

54. This provision follows the same mechanics as Articles 3.4.1 and 3.4.2. The Eligible Payroll Costs and Eligible Tangible Assets are those included in the financial accounts of the PE provided that such accounts are prepared in accordance with an Acceptable Financial Accounting Standard. If the PE does not have separate financial accounts or they are not prepared in accordance with an Acceptable Financial Accounting Standard, the amount of such Eligible Payroll Costs and Eligible Tangible Assets shall be computed as if a PE had separate financial accounts prepared in accordance with the accounting standard used in preparation of the Consolidated Financial Statements of the UPE.

55. Furthermore, similar to Article 3.4.2, the Eligible Payroll Costs and Eligible Tangible Assets have to be adjusted to those that would have been attributed to a PE in accordance with the Tax Treaty or domestic tax law. In the case of PEs as defined by paragraph (c) of the definition in Article 10.1, the Eligible

Payroll Costs and Eligible Tangible Assets have to be those that would have been attributed to the PE in accordance with Article 7 of the OECD Model Tax Convention and related provisions (OECD, 2017^[11]).

56. A condition included in this Article is that the employees and assets have to be located in the jurisdiction in which the PE is located. This condition is similar to the condition that applies to other Constituent Entities, and which is provided in Article 5.3.3 and Article 5.3.4. See Commentary under those articles for purposes of determining, respectively, the jurisdiction where the employees of a PE perform their activity and the jurisdiction where the tangible assets of a PE are located. Where the employees and assets attributed to the PE are not located in the jurisdiction in which it is located, the costs of such employees and assets are excluded from the computation of the Substance-based Income Exclusion.

57. Furthermore, no Eligible Payroll Costs and Eligible Tangible Assets are attributed to a PE described in paragraph (d) of the definition in Article 10.1.

58. The second sentence of Article 5.3.6 states that the Eligible Payroll Costs and Eligible Tangible Assets that are attributed to a PE are not taken into account in the Eligible Payroll Costs and Eligible Tangible Assets of its Main Entity. This ensures that such costs are not taken into account twice for purposes of computing the Substance-based Income Exclusion. Furthermore, where the GloBE Income or Loss of a PE is allocated to the Main Entity in accordance with Article 3.4.5, the Eligible Payroll Costs and Eligible Tangible Assets attributed to such PE remain in the jurisdiction where it is located and therefore are not attributed to the Main Entity.

59. The last sentence of Article 5.3.6 states that the Eligible Payroll Costs and Eligible Tangible Assets of a PE whose income is excluded in accordance with Articles 3.5.3 and 7.1.4 are excluded from the Substance-based Income Exclusion. If the income is partly excluded, then a reduction to the Eligible Payroll Costs and Eligible Tangible Asset has to be made in the same proportion. This ensures that the Eligible Payroll Costs and Eligible Tangible Assets that are used to produce income that is excluded from GloBE Income are not taken into account to shelter income that is included in GloBE income.

Article 5.3.7

60. Article 5.3.7 explains how Eligible Payroll Costs and Eligible Tangible Assets that are included in the financial statements of a Flow-through Entity are allocated properly among Constituent Entities. This provision follows the same mechanics as Article 3.5.1.

61. As a preliminary step, the Eligible Payroll Costs and Eligible Tangible Assets attributed to a PE in accordance with Article 5.3.6 are removed and excluded from the allocation under Article 5.3.7. This is achieved by the phrase “not allocated under Article 5.3.6”. Article 5.3.7 then sets three different rules for different scenarios.

Paragraph (a)

62. Paragraph (a) covers the case where the Flow-through Entity (other than the UPE) is a Tax Transparent Entity. In this scenario, the Financial Accounting Net Income or Loss of the Flow-through Entity has been allocated to the Constituent Entity-owner under Article 3.5.1(b). Article 5.3.7(a) follows the same mechanics by allocating the Flow-through Entity’s Eligible Payroll Costs and Eligible Tangible Assets to its Constituent Entity-owner in the same proportion as the income or loss allocation. The phrase “in the same proportion” means that the same percentages apply with respect to the Financial Accounting Net Income or Loss, and the Eligible Payroll Costs and Eligible Tangible Assets when allocating them between a Flow-through Entity and its Constituent Entity-owners. This paragraph only applies if the Constituent Entity-owner and the employees and assets are located in the same jurisdiction.⁴

Paragraph (b)

63. The second scenario is where the Flow-through Entity is the UPE of the MNE Group. In this case, the Financial Accounting Net Income or Loss of the UPE is allocated to such Entity in accordance with Article 3.5.1(c). However, Article 7.1.1 excludes such income or loss provided that certain conditions are met. In this case, paragraph (b) allocates the Eligible Payroll Costs and Eligible Tangible Assets included in the UPE's financial statements to the extent that they are not excluded from the GloBE income or loss in accordance with Article 7.1.1. Stated differently, the amount of Eligible Payroll Costs and Eligible Tangible Assets associated with the income excluded under Article 7.1.1 is not allocated to the UPE and is excluded from the Substance-based Income Exclusion computations in accordance with the next paragraph.

Paragraph (c)

64. The third rule states that all other Eligible Payroll Costs and Eligible Tangible Assets of the Flow-through Entity not allocated under paragraphs (a) and (b) are excluded from the Substance-based Income Exclusion. This rule applies to the Eligible Payroll Costs and Eligible Tangible Assets associated with the Financial Accounting Net Income or Loss allocated to a Reverse Hybrid Entity. It also applies to the portion of the Eligible Payroll Costs and Eligible Tangible Assets associated with the Financial Accounting Net Income or Loss that has been excluded from the GloBE Income or Loss under Article 3.5.3 (attributable to non-members of an MNE Group) and under Article 7.1.1 (UPE Flow-through Entities).

Article 5.4 - Additional Current Top-up Tax

65. Certain provisions of the GloBE Rules, ETR Adjustment Articles, require or permit a retroactive re-calculation of the ETR and Top-up Tax for a previous Fiscal Year or Fiscal Years taking into account an adjustment to the Adjusted Covered Taxes or the Net GloBE Income (or both) for the year. For example Article 3.2.6 relating to disposition of Local Tangible Assets, require such re-calculations in connection with an election made by the MNE Group. The ETR Adjustment Articles are Articles 3.2.6, 4.4.4, 4.6.1, 4.6.4, and 7.3. When these provisions result in adjustments to the Adjusted Covered Taxes, the change will affect the ETR for one or more of the prior Fiscal Years. The rules for performing the necessary re-calculations for a prior year when required or permitted by an ETR Adjustment Article are set out in Articles 5.4.1 and 5.4.2. Article 5.4.3 sets out a special rule for allocating Top-up Taxes that arise under Article 4.1.5.

Article 5.4.1

66. If the ETR of a jurisdiction is subject to an ETR Adjustment then Article 5.4.1 provides the mechanism for performing the re-calculations for the prior year. Article 5.4.1 treats any additional Top-up Tax computed in respect of those prior Fiscal Years as Additional Current Top-up Tax, which is allocated to Constituent Entities in the jurisdiction under Article 5.2. To avoid the complexity and administrative burden of requiring an amended GloBE Information Return and additional separate payment of Top-up Tax, the Additional Top-Up Tax is instead charged to the Fiscal Year in which the recalculation was performed. In this case Inclusive Framework members considered that the need to avoid compliance and administrative burdens outweighed competing considerations relating to accuracy in connection with the attribution of Top-up Tax based on changes in ownership interests of LTCEs between the prior year and the year the recalculation is undertaken.

67. Article 5.4.1 is not intended to address ordinary mistakes in the computations under the GloBE Rules or adjustments to GloBE Income arising from an examination of a Constituent Entity's application of the IIR or the UTPR. Such adjustments are not made on a prospective basis by including them in Additional Current Top-up Tax. For example, if an MNE Group erroneously excluded an item of income from the

computation of its GloBE Income due to a misclassification of interest income as a dividend, it should follow the relevant administrative procedures for correcting such errors. This may entail filing an amended tax return to increase the amount of Top-up Tax payable in the jurisdiction. Similarly, if this error is discovered by the relevant tax authority on examination, the tax authority may adjust the GloBE tax liability in respect of the relevant Fiscal Year and apply its normal administrative procedures and rules, including assessment of interest or penalties, on that redetermination of tax liability. Stated differently, Article 5.4.1 applies only when there is an adjustment to a local tax item that has a follow-on effect on computations under the GloBE Rules, such as a transfer pricing adjustment that affects the income and tax liability of Constituent Entities in two or more jurisdictions.

Article 5.4.2

68. Article 5.4.2 provides a special rule for when there is additional Top-up Tax due as a result of a recalculation performed in accordance with Article 5.4.1 and there is no Net GloBE Income for the jurisdiction for the current Fiscal Year. This rule provides that the GloBE Income of the Constituent Entities in the jurisdiction shall be increased for the purposes of Article 2.2.2 in an amount equal to the additional Top-up Tax due divided by the Minimum Rate. For this purpose any GloBE Loss determined for the Fiscal Year is disregarded. This rule ensures that when a recalculation results in additional Top-up Tax that is payable in a Fiscal Year with no GloBE Income for a jurisdiction that there is still a mechanism in place by which the Top-up Tax that is owed can be allocated to Parent Entities that may be subject to an IIR.

Article 5.4.3

69. Under Article 4.1.5, Top-up Tax may be due as a result of a negative Adjusted Covered Taxes Amount that represents a larger loss for the jurisdiction than the Expected Adjusted Covered Taxes Amount. As discussed in the Commentary to Article 4.1.5, this rule essentially requires that attributes resulting from permanent differences be paid for with additional Top-up Tax arising in the Fiscal Year in which the attribute is generated. This facilitates the continued alignment of GloBE deferred tax accounts with the accounts used for financial reporting purposes. Article 5.4.3 requires the allocation of the Top-up Tax arising as a result of such permanent differences to the Constituent Entity that generated the attribute resulting from the permanent difference.

70. The following example illustrates the operation of Article 5.4.3. Assume in a Fiscal Year there are two Constituent Entities in Country C. Constituent Entity A reports a GloBE Loss of (100) and Adjusted Covered Taxes of (15) for GloBE purposes. Constituent Entity B also reports a GloBE Loss of (100), but reports Adjusted Covered Taxes of (18) for GloBE purposes. Under Article 4.1.5 the Expected Adjusted Covered Taxes Amount for Country C is (30), but the Adjusted Covered Taxes Amount is actually (33) due to the permanent difference of (3) generated by Constituent Entity B. Article 4.1.5 provides that additional Top-up Tax of 3 is due with respect to Country C for the Fiscal Year. The operation of Article 5.4.3 allocates such Top-up Tax of 3 to Constituent Entity B, since that is the Constituent Entity which generated the permanent difference.

71. Article 5.4.3 also creates an amount of GloBE income for each Constituent Entity to which the Top-up Tax arising under Article 4.1.5 is allocated. This GloBE Income is used solely for purposes of Article 2.2 to determine a Parent Entity's Allocable Share of Top-up Tax arising under Article 4.1.5. The GloBE Income created under Article 5.4.3 is equal to the Top-up Tax allocated to the Entity under Article 5.4.3 divided by the Minimum Rate. For this purpose any GloBE Loss determined for the Fiscal Year is disregarded.

72. It is possible for GloBE Income to be created for Constituent Entities in a jurisdiction for the purposes of Article 2.2.2 under both Articles 5.4.2 and 5.4.3. In this scenario, each article is applied without regard to the income created under the other article. For purposes of Article 2.2.2, the GloBE Income for

any Constituent Entity for which GloBE Income has been created under both articles is the sum of the income created under each article.

Article 5.4.4

73. When Additional Current Top-up Tax arises from a re-calculation under Articles 5.4.1 to 5.4.3, Article 5.4.4 treats the Constituent Entity to which the Additional Current Top-up Tax is allocated as a Low-Tax Constituent Entity for purposes of Chapter 2. Whether a jurisdiction is a Low-Tax Jurisdiction is determined annually and the Additional Current Top-up Tax may arise in a year for which the jurisdiction is not a Low-Tax Jurisdiction. The rules of Chapter 2 apply with respect to Low-Taxed Constituent Entities. This rule ensures that those rules apply properly to the Additional Current Top-up Tax to years in which the Constituent Entity's location is not a Low-Tax Jurisdiction.

Article 5.5 - De minimis exclusion

74. Article 5.5 provides a jurisdictional exclusion for LTCEs of an MNE Group when both (i) the aggregated income and (ii) the revenue of those entities do not exceed agreed monetary thresholds. Article 5.5.1 sets out the effects of the exclusion as well as the required conditions to benefit from that exclusion. Articles 5.5.2 and 5.5.3 further provide the methodology for computing the relevant indicators on a jurisdictional basis. The policy intent underlying Article 5.5 is to avoid the complexities of a full ETR computation in cases where the amount of any Top Up Tax would not seem to justify the associated compliance and administrative costs.

Article 5.5.1

Effects of the de minimis exclusion

75. Article 5.5.1 provides that the Top-up Tax for the Constituent Entities located in a jurisdiction shall be deemed to be zero for a given Fiscal Year when all Constituent Entities located in the same jurisdiction meet the requirements for the de minimis exclusion.

76. Article 5.5.1 further provides that this exclusion applies notwithstanding the requirements otherwise provided in Chapter 5, such as the requirement to determine the ETR of a jurisdiction and compute the Top-up Tax due, if any. This means that there is no need for the MNE Group to compute the ETR of the Constituent Entities that are located in the jurisdiction that meets the de minimis thresholds and no need to calculate the amount of Top-up Tax that would have been due if the exclusion did not apply.

77. The exclusion applies on an annual basis. This means that a jurisdiction can fall under the de minimis exclusion for a given Fiscal Year, but not necessarily for the preceding or the following year. If a Constituent Entity was located in a jurisdiction to which Article 5.5.1 applied the first year when the MNE is subject to the GloBE Rules, the Transition Rules provided in Article 9.1 shall apply to such Constituent Entity at the beginning of the first Fiscal Year for which Article 5.5.1 does not apply to the jurisdiction. If a Constituent Entity was located in a jurisdiction to which Article 5.5.1 starts to apply one or several Fiscal Years after the MNE is subject to the GloBE Rules, the Filing Constituent Entity may nevertheless still be subject to filing obligations under the GloBE Rules during the Fiscal Year(s) where the de minimis exclusion applies (e.g. to ensure that an earlier deferred tax liability reversed within the required timeframe).

78. The exclusion applies to all Constituent Entities of an MNE Group that are located in the same jurisdiction, unless those Entities are not eligible for the exclusion such as Investment Entities. This means that a jurisdiction can be treated as a de minimis jurisdiction for a given Fiscal Year for a given MNE Group but not for another MNE Group.

Elective exclusion

79. Article 5.5.1 applies at the election of the Filing Constituent Entity. As provided in Article 8.1.4 (b), the Filing Constituent Entity shall elect and provide the relevant information in its GloBE Information Return showing that the required conditions are met to benefit from the exclusion. This election is an annual election.

Conditions for the exclusion

80. Article 5.5.1 provides two conditions for a jurisdiction to be eligible for the de minimis exclusion. The first condition requires the Average GloBE Revenue of the MNE Group in that jurisdiction to be less than EUR 10 million, while the second condition requires the Average GloBE Income or Loss of the MNE Group in that jurisdiction to be a loss or less than EUR 1 million. Both the Average GloBE Revenue and Average GloBE Income are determined by applying the same rules used to compute the GloBE Income of a jurisdiction, as provided in Article 5.5.3.

81. The two conditions provided in Article 5.5.1 are aggregate and cumulative. This means that the income and revenues of all Constituent Entities located in the same jurisdiction must be aggregated for the purposes of the de minimis exclusion and if, for a Fiscal Year, the aggregate outcome for those Constituent Entities fail to meet one of the two conditions, the jurisdiction is not eligible for the de minimis exclusion for that Fiscal Year. As provided in Article 5.5.2, the relevant elements used for purposes of this exclusion are computed by using an average, which should minimise the volatility and the risk that a jurisdiction's eligibility for the de minimis exclusion varies from one year to the next.

82. Article 5.5.1 further provides that the election applies notwithstanding the requirements otherwise provided in Chapter 5. This means that the election available in Article 5.5.1 does not require the MNE Group to compute the Average GloBE Revenue and Average GloBE Income or Loss of the members of a Minority-Owned Subgroup as if they were a separate MNE Group or of a Minority-Owned Constituent Entity on an entity basis. Therefore, the GloBE Revenue and the GloBE Income or Loss of those entities is taken into account for purposes of determining the Average GloBE Revenue and the Average GloBE Income or Loss of the jurisdiction where they are located.

83. The two conditions provided in Article 5.5.1 are denominated in the Euro currency. Like the revenue threshold, this may require the MNE Group to convert its revenue and income into Euros and may require a jurisdiction that measures the de minimis conditions in local currency to re-base the de minimis threshold amounts on a yearly basis to align with the references provided in the GloBE Rules.

Article 5.5.2

84. Article 5.5.2 provides that the GloBE Revenue and the GloBE Income or Loss of a jurisdiction shall be averaged for purposes of testing whether a jurisdiction meets the criteria for the de minimis exclusion. For each of those indicators, Article 5.5.2 provides that the values of the current Fiscal Year (whether income or loss) shall be averaged with that of the preceding two Fiscal Years for purposes of testing whether the jurisdiction is below the threshold. Using a three-year average is intended to simplify both compliance with the rule by MNE Groups and administration of the rule by tax authorities. It is, however, acknowledged that the average may result in volatile outcomes where a Fiscal Year with a significant amount of income (or loss) drops out of the three-year average.

85. To avoid skewing the computation of the average, the second sentence of Article 5.5.2 provides that some Fiscal Years shall be excluded from the computation of the Average GloBE Revenue and the Average GloBE Income or Loss when there are no Constituent Entities with either GloBE Revenue or GloBE Losses (in the absence of revenue) that were located in the jurisdiction for that Fiscal Year. This applies when there are no Constituent Entities located in the jurisdiction for a given Fiscal Year. It can also

arise when there are only dormant Constituent Entities located in the jurisdiction. Before the GloBE Rules come into effect, there are also no Constituent Entities with GloBE Revenue or GloBE Income or Loss in any jurisdiction. This means that if, for instance, the Constituent Entities located in a given jurisdiction have an aggregate GloBE Income that equals or exceeds EUR 1 million for the first year when the GloBE Rules apply, the determination will be based solely on the revenue, income and loss of that year and the jurisdiction will not benefit from the de minimis exclusion for that year.

86. The computation of the average provided under Article 5.5.2 relies on the assumption that Fiscal Years have the same duration. If one Fiscal Year is shorter, taking into account the GloBE Revenue or the GloBE Income or Loss of that year as if it accounted for the entire year would also skew the results. In such a case, the average shall be computed by adjusting the corresponding revenue and income (or loss) calculations in proportion to the period covered by the short Fiscal Year over a calendar year, in order to obtain an annual GloBE Revenue and GloBE Income or Loss for purposes of the computation.⁵

Article 5.5.3

87. Article 5.5.3 provides the definitions of GloBE Revenue of a jurisdiction and GloBE Income or Loss of a jurisdiction that are used for purposes of Article 5.5.2.

(a) GloBE Revenue of a Jurisdiction

88. Paragraph (a) provides that the GloBE Revenue of a jurisdiction is the sum of the revenue of all Constituent Entities located in the jurisdiction for a Fiscal Year, taking into account the adjustments calculated in accordance with Chapter 3. Chapter 3 provides the methodology for computing the GloBE Income or Loss of a Constituent Entity. Article 3.1 provides that the starting point for determining the GloBE Income or Loss of a Constituent Entity is the Financial Accounting Net Income or Loss determined for that Constituent Entity. Similarly, the starting point for determining the revenue of a Constituent Entity is the financial accounting revenue used in preparing the Consolidated Financial Statements, unless another Accounting Standard is applied, as provided in Article 3.1.3.

89. Chapter 3 provides the adjustments that shall apply to determine the GloBE Income or Loss of a Constituent Entity. Only the adjustments that affect the amount of the revenue of a Constituent Entity shall be taken into account for computing the GloBE Revenue of a jurisdiction. A number of adjustments provided in Chapter 3 may affect the amount of revenue of a Constituent Entity. For example, depending upon the treatment of the following items in the financial accounts, the adjustments required by Article 3.2 in respect thereof may affect the amount of revenue:

- the adjustments provided for in Article 3.2.2, under paragraphs (b) (Excluded Dividends), (c) (Excluded Equity Gain or Loss), (d) (Included Revaluation Method Gain or Loss), (e) (Gain or loss from disposition of assets and liabilities excluded under Article 6.3.), (f) (Asymmetric Foreign Currency Gain or Loss) or (h) (Prior Period Errors and Changes in Accounting Principles);
- the rule provided in Article 3.2.3 in situations where transactions between Constituent Entities form part of the revenue of a Constituent Entity;
- the rule provided in Article 3.2.4 concerning refundable tax credits;
- the elective adjustments provided in Article 3.2.5 and Article 3.2.6 relating to gains or losses in respect of an asset for which the Constituent Entity uses fair value or impairment accounting
- the elective treatment of income and gains from transactions between Constituent Entities that are located in the same jurisdiction as provided in Article 3.2.8;
- the rule provided in Article 3.2.9 applicable to insurance companies;

- amounts recognised as an increase to the equity of a Constituent Entity attributable to distributions received or receivable in respect of Additional Tier One Capital held by the Constituent Entity as provided in Article 3.2.10;
- the rules referred to in Article 3.2.11 (referring to provisions of Articles 6 and 7) to the extent they affect the amount of the revenue of a Constituent Entity;
- the exclusion provided in Article 3.3 in relation to International Shipping Income or loss and Qualified Ancillary International Shipping Income;
- the rules provided in Article 3.4 (Allocation of Income or Loss between Main Entity and PE) to the extent they affect the amount of the revenue of a Constituent Entity; and
- the rules provided in Article 3.5 (Allocation of Income or Loss from a Flow-through Entity) to the extent they affect the amount of the revenue of a Constituent Entity.

90. On the other hand, Chapter 3 also provides a number of adjustments that relate to expenses only, and therefore are unlikely to affect the amount of the revenue of a Constituent Entity. These adjustments shall not be taken into account in determining the GloBE Revenue of a jurisdiction. This is the case for :

- the adjustments provided in Article 3.2.2, under paragraphs (a) (Net Taxes Expense), (g) (Policy Disallowed Expenses) or (i) (Accrued Pension Expense);
- the elective adjustment provided in Article 3.2.2 that relates to the amount of the stock-based compensation expense;
- the rule provided under Article 3.2.7 in relation to the expenses accrued in respect of a liability to another Constituent Entity;
- amounts recognised as a decrease to the equity of a Constituent Entity attributable to distributions paid or payable in respect of Additional Tier One Capital issued by the Constituent Entity as provided in Article 3.2.10;
- the rules referred to in Article 3.2.11 (referring to provisions of Articles 6 and 7) to the extent they do not affect the amount of the revenue of a Constituent Entity;
- the exclusion provided in Article 3.3.5 that relates to the expenses attributed to the International Shipping Income or Qualified Ancillary International Shipping Income;
- the rules provided in Article 3.4 (Allocation of Income or Loss between Main Entity and PE) to the extent they do not affect the amount of the revenue of a Constituent Entity; and
- the rules provided in Article 3.5 (Allocation of Income or Loss from a Flow-through Entity) to the extent they do not affect the amount of the revenue of a Constituent Entity.

(b) GloBE Income or Loss of a Jurisdiction

91. Paragraph (b) provides that the GloBE Income or Loss of a jurisdiction is the Net GloBE Income of that jurisdiction, if any, or the Net GloBE Loss of that jurisdiction. The Net GloBE Income of a jurisdiction is defined in Article 5.1.2 as the positive amount, if any, that is computed as the difference between the sum of the GloBE Income of all Constituent Entities and the sum of the GloBE Losses of all Constituent Entities, where both elements are determined in accordance with the rules provided in Chapter 3. If this difference is nil or negative, the outcome is a loss and that is the Net GloBE Loss of a jurisdiction.

Post-filing ETR Adjustments

92. The GloBE Revenue and the GloBE Income or Loss of a jurisdiction are computed for each Fiscal Year to determine whether the de minimis exclusion applies. An ETR Adjustment Article may apply in a subsequent year such that the Effective Tax Rate of a jurisdiction for a previous Fiscal Year is required or permitted to be recalculated, which may also require the re-computation of the GloBE Income or Loss of that jurisdiction for that Fiscal Year or any intervening Fiscal Years. When the GloBE Income or Loss is

adjusted under an ETR Adjustment Article, the GloBE Revenue shall also be adjusted as appropriate and necessary. Adjustments that reduce GloBE Income and/or GloBE Revenue for a previous Fiscal Year will not make a jurisdiction eligible for the de minimis exclusion in a previous Fiscal Year. However, adjustments that increase the GloBE Income and/or the GloBE Revenue of the jurisdiction may result in the Average GloBE Income or the Average GloBE Revenue of the jurisdiction no longer being below the threshold for the de minimis exclusion for a previous Fiscal Year or Years. In such a case, Article 5.5 is no longer applicable for the relevant Fiscal Year or Years and the Filing Constituent Entity must provide the relevant information required in the GloBE Information Return with respect to that jurisdiction for those Fiscal Years, without applying Article 5.5.

93. For instance, in the case of a re-calculation pursuant to Article 3.2.6, the GloBE Revenue for a previous Fiscal Year shall be increased by the amount of Aggregate Asset Gain set-off against a Net Asset Loss for the year under paragraphs (b) or (c) and the amount allocated to the year under paragraph (d). Another example is Article 4.6.1 which addresses post-filing adjustments provides that the ETR is recomputed for a previous Fiscal Year when post-filing adjustments result in a reduction of the Effective Tax Rate for that year. Those adjustments also require re-computing the GloBE Income of that Fiscal Year and the intervening Fiscal Years, as necessary and appropriate. In circumstances where the GloBE Income would need to be increased for those Fiscal Years where post-filing adjustments result in a reduction of the Effective Tax Rate, this may have an impact on the de minimis exclusion. If the adjusted GloBE Income results in the Average GloBE Income exceeding the EUR 1 million threshold that provided in Article 5.5.1 for any Fiscal Year, the de minimis exclusion would not be applicable for those years.

Changes in the Scope of the MNE Group

94. As mentioned previously, the GloBE Revenue and the GloBE Income or Loss of a jurisdiction is determined in accordance with the principles and adjustments provided in Chapter 3, which provides the methodology for computing the GloBE Income or Loss of a Constituent Entity, the starting point being the financial accounts used in preparing the Consolidated Financial Statements. This means that the determinations of GloBE Revenue and GloBE Income or Loss of a jurisdiction under Article 5.5.3 are not adjusted to take into account periods when a Constituent Entity does not belong to the MNE Group and are limited based on whether an Entity was a Constituent Entity of the MNE Group in the previous Fiscal Years. Thus, if an MNE Group acquires Entities in a merger, the GloBE Revenue and GloBE Income or Loss of those Entities determined for periods prior to the merger are not taken into account for purposes of determining the three-year averages under Article 5.5.3. Similarly, if a Constituent Entity leaves the MNE Group, the GloBE Revenue and GloBE Income or Loss of that Entity determined for periods prior to the disposition of that Constituent Entity are still taken into account for purposes of determining the three-year averages under Article 5.5.3.

Article 5.5.4

95. Article 5.5.4 provides that an election under Article 5.5 shall not apply to Stateless Constituent Entities. Equally, Article 5.5.4 further provides that an election under Article 5.5 shall not apply to a Constituent Entity that is an Investment Entity. The policy intent underlying the de minimis exclusion is to avoid the complexities of determining the Adjusted Covered Taxes for the ETR and Top-up Tax calculations where the potential amount of Top-up Tax does not seem to justify the compliance and administrative burden. The election is not applicable to these Constituent Entities because their ETR is computed on an Entity basis and they are typically not subject to tax. Thus, because the ETR determined for these Entities will usually be zero and the Net GloBE Income or Loss for the jurisdiction must be determined in any case to apply the exclusion, applying the exception to these Entities would not produce a significant reduction in compliance burdens, but would instead encourage MNE Groups to separate its tax-exempt income into multiple Stateless Constituent Entities and Investment Entities that qualify for the de minimis exclusion.

96. Since Stateless Constituent Entities and Investment Entities are not eligible for the de minimis exclusion, their revenue and GloBE income are excluded from the De Minimis Exclusion computations in Article 5.5.3 for purposes of determining whether a jurisdiction is eligible for the de minimis exclusion so that such revenue or income will not cause a jurisdiction to fail the de minimis tests.

Article 5.6 - Minority-Owned Constituent Entities

97. Special rules are included in Article 5.6 for computing the ETR and Top-up Tax of Minority-Owned Constituent Entities. A Minority-Owned Constituent Entity is a Constituent Entity of the MNE Group where the UPE holds directly or indirectly 30% or less of its Ownership Interests. The Entities are Constituent Entities because the UPE holds their Controlling Interests, despite the small ownership percentage. Special rules are needed for Minority-Owned Constituent Entities because a UPE may have several Minority-Owned Constituent Entities with operations in the same jurisdiction but with different groups of owners that are not Group Entities. If the income and taxes of these different Constituent Entities were blended in the jurisdictional ETR computations, low-tax outcomes in one Entity could result in a Top-up Tax for the jurisdiction, some of which would be borne by non-Group Entity owners of a different Constituent Entity. While this can occur to some extent under the normal jurisdictional blending rules, the magnitude of the effect in the context of Minority-Owned Constituent Entities and the potential detrimental impact on these investment structures justifies a different rule.

98. The special rules in Article 5.6 can also apply to Permanent Establishments if the Main Entity and the Permanent Establishment meet the definition of a Minority-Owned Constituent Entity.

99. Article 5.6.1 applies with respect to members of a Minority-Owned Subgroup, which is a subgroup within the MNE Group comprised of a Minority-Owned Parent Entity and its Minority-Owned Subsidiaries. Article 5.6.2 covers the case where a Minority-Owned Constituent Entity is not part of a Minority-Owned Subgroup. The terms Minority-Owned Constituent Entity, Minority-Owned Subgroup, Minority-Owned Parent Entity and Minority-Owned Subsidiary are defined in Article 10.1 and discussed below.

100. A Minority-Owned Parent Entity is a Minority-Owned Constituent Entity that holds directly or indirectly the Controlling Interests of another Minority-Owned Constituent Entity. If there are two or more Parent Entities that meet the definition of Minority-Owned Constituent Entity in the same ownership chain, only the Entity that is in the highest level in the ownership chain is considered to be the Minority-Owned Parent Entity.

101. A Minority-Owned Subsidiary is defined as a Minority-Owned Constituent Entity whose Controlling Interests are held, directly or indirectly, by a Minority-Owned Parent Entity. The Minority-Owned Parent Entity and its Minority-Owned Subsidiaries comprise a Minority-Owned Subgroup.

102. Not all Constituent Entities whose Controlling Interests are held by a Minority-Owned Parent Entity are considered Minority-Owned Subsidiaries and members of a Minority-Owned Subgroup. They must also meet with the definition of a Minority-Owned Constituent Entity. For instance, assume that UPE holds 60% of the Ownership Interests of B Co, but the Controlling Interests of B Co are held through A Co, a Constituent Entity that is the Minority-Owned Parent Entity of a Minority-Owned Subgroup. In this case, B Co does not meet the requirements to be a Minority-Owned Constituent Entity because the UPE holds more than 30% of its Ownership Interests. The fact that its Controlling Interests are held through a Minority-Owned Parent Entity does not make it a Minority-Owned Subsidiary and member of the Minority-Owned Subgroup.

Article 5.6.1

103. Article 5.6.1 is a special rule that only applies to Minority-owned Constituent Entities that are members of a Minority-Owned Subgroup. It states that the computation of the ETR and Top-up Tax for a

jurisdiction in accordance with Chapters 3 to 7, and Article 8.2 shall apply as if they were a separate MNE Group. This means that jurisdictional computations made with respect to members of the Minority-Owned Subgroup shall be done separately from the rest of the MNE Group. The second sentence further clarifies that the Adjusted Covered Taxes and GloBE Income or Loss of members of a Minority-Owned Subgroup are excluded from the determination of the remainder of the MNE Group's ETR in Article 5.1.1 and Net GloBE Income in Article 5.1.2.

104. Thus, an MNE Group could have two or more computations with respect to Constituent Entities located in a jurisdiction, one for members of the Minority-Owned Subgroup and the other for the rest of the MNE Group. The result does not change regardless that a portion of the Ownership Interests are held directly by the UPE or other Parent Entities that are not part of the Minority-Owned Subgroup. For example, the UPE holds 20% of the Ownership Interests of A Co, which owns 90% of B Co 1 and B Co 2 (located in jurisdiction B). The remainder 10% of the Ownership Interests of B Co 1 and B Co 2 are held directly by the UPE. All Entities are Constituent Entities of an MNE Group. A Co is a Minority-Owned Parent Entity, while B Co 1 and B Co 2 are its Minority-Owned Subsidiaries. In this situation, the ETR of jurisdiction B with respect to B Co 1 and B Co 2 is computed separately from the ETR computation of any other Constituent Entities of the MNE Group located in jurisdiction B.

105. Article 5.6.1 does not change the mechanics of the provisions of GloBE Rules other than the computation of the jurisdictional ETR and the consequential changes to the Top-up Tax computation of the members of the Minority-Owned Subgroup. For instance, if the Minority-Owned Parent Entity is a Flow-through Entity, its Financial Accounting Net Income or Loss is allocated to its Constituent Entity-owners in accordance with Article 3.5.1(b) (unless it has been allocated to a PE under Article 3.5.1(a)). Equally, Article 5.6.1 has no effect on the eligibility of a jurisdiction for the de minimis exclusion provided in Article 5.5 (see above the Commentary on the conditions for the exclusion under Article 5.5.1). Furthermore, the charging provisions in Chapter 2 apply normally. For example, the Minority-Owned Parent Entity is not treated as the UPE of the Minority-Owned Subgroup. The UPE of the MNE Group is still required to apply the IIR with respect to the members of the Minority-Owned Subgroup. Similarly, the Minority-Owned Parent Entity and any other Parent Entity that is a POPE are still required to apply the IIR with respect to their Ownership Interests in the Minority-Owned Constituent Entities of the Minority-Owned Subgroup.

Article 5.6.2

106. Article 5.6.2 is a rule that applies only to a Minority-Owned Constituent Entity that is not a member of a Minority-Owned Subgroup. The provision states that the ETR and Top-up Tax of the Entity is computed on an entity basis in accordance with Chapters 3 to 7, and Article 8.2. It further clarifies that its Adjusted Covered Taxes and GloBE Income or Loss are excluded from the determination of the remainder of the MNE Group's ETR in Article 5.1.1 and Net GloBE Income in Article 5.1.2. This provision prevents the 70% or more of the Net Income or Loss and Adjusted Covered Taxes of the Entity, which do not effectively belong to the UPE, from being blended with the Net Income or Loss and Adjusted Covered Taxes of the other Constituent Entities of the MNE Group. However, Article 5.6.2 has no effect on the eligibility of a jurisdiction for the de minimis exclusion provided in Article 5.5 (see above the Commentary on the conditions for the exclusion under Article 5.5.1).

107. The last sentence of this provision states that it does not apply if the Minority-Owned Constituent Entity is an Investment Entity. Therefore, the special provisions applicable to Investment Entities in Articles 7.4 and 7.5 have priority and apply in these situations.

References

- IFRS Foundation (2022), *International Financial Reporting Standards*, <https://www.ifrs.org/>. [2]
- OECD (2017), *Model Tax Convention on Income and on Capital: Condensed Version 2017*, OECD Publishing, Paris, https://dx.doi.org/10.1787/mtc_cond-2017-en. [1]
- OECD (2015), *Transfer Pricing Documentation and Country-by-Country Reporting, Action 13 - 2015 Final Report*, OECD/G20 Base Erosion and Profit Shifting Project, OECD Publishing, Paris, <https://dx.doi.org/10.1787/9789264241480-en>. [6]

Notes

¹ See page 34 of Action 13 Report (OECD, 2015^[6]): “In the tenth column of the template, the Reporting MNE should report the total number of employees on a full-time equivalent (FTE) basis of all the Constituent Entities resident for tax purposes in the relevant tax jurisdiction. The number of employees may be reported as of the year-end, on the basis of average employment levels for the year, or on any other basis consistently applied across tax jurisdictions and from year to year. For this purpose, independent contractors participating in the ordinary operating activities of the Constituent Entity may be reported as employees. Reasonable rounding or approximation of the number of employees is permissible, providing that such rounding or approximation does not materially distort the relative distribution of employees across the various tax jurisdictions. Consistent approaches should be applied from year to year and across entities.”

² Under some financial accounting standards timber tracts are accounted for the same as other natural resources, i.e., cost model. However, under IFRS, specifically IAS 41 – Agriculture, “biological assets”, which includes timber tracts, are valued at their fair value less estimated costs to sell, with changes in fair value included in profit or loss (IFRS Foundation, 2022^[2]). For purposes of the carve-out, a deemed depletion charge for timber tracts must be derived using the cost model.

³ Some financial accounting standards require lessee’s to distinguish between “operating leases” and “finance leases”. Other standards, including IFRS, have a single lessee accounting model which requires a lessee to recognise assets and liabilities for all leases with a term of more than 12 months, unless the underlying asset is of low value.

⁴ The application of Article 5.3.7 is illustrated in the Examples to the Commentary on the Model GloBE Rules under Pillar Two: <https://www.oecd.org/tax/beps/tax-challenges-arising-from-the-digitalisation-of-the-economy-global-anti-base-erosion-model-rules-pillar-two-examples.pdf>.

⁵ The application of Article 5.5.2 is illustrated in the Examples to the Commentary on the Model GloBE Rules under Pillar Two: <https://www.oecd.org/tax/beps/tax-challenges-arising-from-the-digitalisation-of-the-economy-global-anti-base-erosion-model-rules-pillar-two-examples.pdf>.

6 Corporate Restructurings and Holding Structures

1. Chapter 6 contains special rules dealing with corporate restructurings (including mergers, acquisitions, and demergers) as well as Articles that address the application of the GloBE Rules to certain holding structures such as JV investments and Multi-Parented MNE Groups.

Overview

2. Article 6.1 explains how the consolidated revenue threshold is applied after a merger and a demerger. In the case of a merger, this Article sets out special rules for measuring the consolidated revenue of the Entities or Groups involved in the merger for purposes of the four-year revenue threshold test in Article 1.1.1. In the case of a demerger, the Article includes an additional rule that supplements the revenue threshold test in Article 1.1.1. The Article also defines merger and demerger for these purposes.

3. Article 6.2 deals with cases where an Entity joins or leaves the MNE Group. In these cases, special rules are needed to apply the GloBE Rules in respect of the Constituent Entity that enters or leaves an MNE Group during the Fiscal Year. The rules impact the calculations for the GloBE Income or Loss, Adjusted Covered Taxes, and Substance-based Income Exclusion, and the way the IIR is applied under these circumstances.

4. Article 6.3 deals with situations in which the assets and liabilities of a Constituent Entity are disposed or acquired directly, including as part of a GloBE Reorganisation. Article 6.3 provides rules to determine whether and the extent to which gain or loss is recognised on the disposition and the carrying value to be used by the acquirer for the purposes of determining its GloBE Income or Loss in subsequent Fiscal Years.

5. Article 6.4 establishes special rules for JVs. These rules apply where an UPE holds, directly or indirectly, at least 50% of the Ownership Interest of a JV that is reported under the equity method in its Consolidated Financial Statements. Article 6.4 brings such JVs into scope of the GloBE Rules, along with their JV Subsidiaries.

6. Finally, Article 6.5 provides special rules for the treatment of Multi-Parented MNE Groups under the GloBE Rules.

7. The special rules related to corporate restructurings in Articles 6.2 and 6.3 are intended to produce outcomes that are generally aligned with the local tax treatment of such transactions. However, the precise tax treatment of restructurings varies among Inclusive Framework jurisdictions and additional guidance may be needed to address the application of the GloBE Rules in certain scenarios, the treatment of specific aspects of the GloBE Rules (e.g. elections) when Constituent Entities leave or join an MNE Group or when a new MNE Group is formed or an MNE Group ceases to exist, the carrying value of Ownership Interests received as consideration in a restructuring, and the measurement and treatment of deferred tax assets and liabilities arising in connection with certain business combinations. As part of the GloBE

Implementation Framework, consideration will be given to providing Agreed Administrative Guidance related to these issues..

Purchase Accounting and Business Acquisitions

8. Financial accounting standards used in preparing Consolidated Financial Statements do not usually provide for non-recognition of gain or loss on the disposition of assets or liabilities, either individually or as part of the disposition of an entire business. This is true regardless of whether the assets and liabilities are disposed of directly or whether the disposition is effected through a sale of Ownership Interests in a Constituent Entity. In addition, the Ownership Interests of a Constituent Entity are not recognised as an asset in the Consolidated Financial Statements; instead, the assets and liabilities of the Constituent Entity are consolidated with those of the MNE Group. Thus, when they are disposed of (even via a sale of the Ownership Interests), the gains and losses on the underlying assets and liabilities are generally included in the MNE Group's Financial Accounting Net Income or Loss in the Consolidated Financial Statements. However, for GloBE purposes the Financial Accounting Net Income or Loss is determined using the separate entity position of the Constituent Entity used in preparing the Consolidated Financial Statements.

9. Financial accounting standards provide correlative treatment of the acquired assets and liabilities. Financial accounting standards generally require the acquirer to record acquired assets and liabilities at their acquisition date fair value, irrespective of the acquisition price. This is the normal accounting treatment for when a standalone business is acquired, also referred to as a business combination. To the extent an acquisition of assets or liabilities is not considered to be a standalone business the acquired assets are typically accounted for at cost (i.e. the acquisition price). In a business combination (i.e. an acquisition of a standalone business), if the acquisition price exceeds the fair value of the acquired assets, financial accounting rules generally treat the excess as a goodwill asset. And if the acquisition price is less than the fair value of the acquired assets, financial accounting rules generally treat the shortfall as a bargain purchase and require a corresponding income inclusion. In many cases, particularly for Entity acquisitions, the fair value adjustments to the carrying value of assets and liabilities are reflected in the consolidated financial accounts, rather than the separate financial accounts of the acquired Constituent Entity or the Constituent Entity that acquired the assets and liabilities. "Push-down accounting" refers to the situation where the fair value adjustments are reflected in (i.e. "pushed down to") the financial accounts of the Constituent Entity. Push-down accounting is not permitted in some Acceptable Financial Accounting Standards and not permitted in all circumstances in some of those standards.

10. Given the GloBE Rules primarily focus on the position of individual Entities rather than the full consolidated position of the MNE Group, it is important to distinguish between the accounting for an acquisition of a business through a share acquisition (i.e. acquiring the Ownership Interest in the Entity) and an asset acquisition (i.e. acquiring the underlying assets and liabilities of the business). From a consolidation perspective, the accounting is the same, however, the individual Entity position is often different. In a share acquisition, the individual Entity position is often unaffected as all that has changed from the Entity's perspective is the shareholder whereas in an asset acquisition new assets and liabilities will be brought onto the balance sheet. As a result, the purchase accounting adjustments to fair value are usually reflected in the individual Entity position for an asset acquisition whereas for a share acquisition they are usually only reflected as a consolidation adjustment to get to the full consolidated position.

11. The tax rules of many Inclusive Framework jurisdictions do not require recognition of a gain or loss in certain transfers of assets and liabilities, and provide for a corresponding continuation of the historical basis in the assets and liabilities after the transfer. For example, when the shares of an Entity are transferred to a new owner, the basis of the Entity's assets and amount of its liabilities is generally unaffected irrespective of whether the seller is subject to tax on a gain from the sale of its shares. Similarly, gains from transfers of assets and liabilities that qualify as a GloBE Reorganisation are generally not

subject to tax and the acquiring Entity must use the historical tax basis of the assets and amounts of the liabilities in computing taxable income after the transfer.

12. Generally, when there is a difference in the financial accounting and tax carrying value (basis or amount) of assets and liabilities, financial accounting rules require the MNE Group to establish deferred tax liabilities or deferred tax assets because the difference will manifest itself as a temporary difference in the computation of taxable and accounting income. In a business combination, financial accounting rules generally require creation of deferred tax liabilities and assets to the extent that the acquiring Entity will be subject to tax on the differences in carrying value. Unlike most deferred tax assets and liabilities, the ones created in connection with a business combination do not affect the income tax expense computation when they arise because the net effect of recognition of such deferred tax assets and liabilities is recorded in accounting goodwill and not as income tax expense. Consequently, recognition of deferred tax assets and liabilities will not give rise to Adjusted Covered Taxes for GloBE purposes at the time of the business combination. They only affect the income tax expense computation when they reverse.

13. For example, assume that MNE Group 1 owns all of the Ownership Interests of A Co which is resident in jurisdiction A. A Co holds a standalone business and has assets with total carrying value of USD 100 and a tax basis of USD 100, the tax rate in jurisdiction A is 15%.

14. MNE Group 1 decides to sell its Ownership Interest of A Co to MNE Group 2. MNE Group 2 agrees to pay USD 300 for A Co on the basis that it considers the assets of A Co to be worth USD 300. In this scenario, the tax basis of the underlying assets is unaffected by the acquisition. As a result, there is now a difference between the financial accounting carrying value in the consolidated financial statements (USD 300) and the tax carrying value (USD 100) of A Co's assets, and deferred tax liabilities should be recognised in relation to these temporary differences (USD 30 = (USD 300 – USD 100) * 15%).

| | Amount USD |
|--|---------------|
| Fair value of net assets acquired | 300 |
| Deferred tax liabilities recognised on acquisition (30 = (300 – 100) * 15%) | (30) |
| Goodwill (balancing amount to arrive at total purchase consideration of 300) | 30 |
| Total Carrying value (equal to purchase consideration) | 300 |

15. There would be no deferred tax expense arising from the recognition of the deferred tax liabilities, instead a goodwill asset is recognised. Thereafter, when MNE Group 2 sells the assets for USD 300, it has no financial accounting gain or loss because the carrying value of the assets is USD 300 (assuming no changes to fair value since the original acquisition). There will be a gain for tax purposes because the assets are sold for USD 300 but the tax base is USD 100, which represents the tax deduction available on sale of the assets. This gives rise to a taxable gain of USD 200 and a tax charge of USD 30 (= USD 200 * 15%), however this is offset by a reversal of the deferred tax liability of USD 30 recognised on the original acquisition. As a result the nil accounting impact from this disposal is mirrored by the nil total tax (current tax plus deferred tax) impact.

16. It is worth noting that the deferred tax liability of USD 30 recognised on the acquisition would only be recognised in the consolidated financial statements of MNE Group 2 and not in the individual entity position.

17. Financial accounting adjustments to the carrying value of assets and liabilities arising in connection with purchase accounting for a business combination generally are not taken into account in the computation of GloBE Income or Loss, as discussed in the Commentary to Article 3.1.2. For example, purchase accounting adjustments and the corresponding deferred tax assets and liabilities are not taken into account in respect of a transaction governed by Article 6.2.1. After such transactions, the historical

carrying values of the acquired assets and liabilities (i.e. the values excluding any purchase accounting adjustments made on acquisition) must be used to compute the GloBE Income or Loss, which will generally be consistent with the computation of taxable income under the local tax rules. Therefore, any deferred tax assets and liabilities associated with purchase accounting adjustments in the financial accounts must also be excluded from the computation of Adjusted Covered Taxes under Article 4.1 to prevent distortions in the ETR computations. The same is true for purchase accounting adjustments and associated deferred tax assets and liabilities in the financial accounts arising in connection with a GloBE Reorganisation that is subject to the rules of Article 6.3.2.

18. In some cases it is appropriate to reflect purchase accounting adjustments in the GloBE income or loss. Purchase accounting adjustments arising in connection with transactions governed by Article 6.2.2, Article 6.3.1 and Article 6.3.4 should be taken into account even if those adjustments are reflected in the financial accounts at the consolidated level, rather than the Constituent Entity level. Purchase accounting adjustments arising in connection with transactions governed by Article 6.3.3 should be taken into account to the extent they relate to Non-Qualifying Gain or Loss. In most cases, those transactions will be fully taxable at the local level and there may be deferred tax assets and liabilities recognised as the fair value of each of the asset and liability recognised in the financial accounts may not be same as tax basis of assets and liabilities recognised for tax purposes. Similarly, not all of the assets recognised for accounting purposes may be recognised for tax purposes and the value of some accounting assets might be merged or allocated to the basis of another asset for tax purposes. In the case of tax-deductible goodwill, there may be deferred tax assets recognised at the time of initial recognition of accounting goodwill, representing fair value of accounting goodwill and future tax deductions of goodwill over a future period or upon disposal of goodwill. Future accounting amortisation and impairment on such assets recognised at acquisition date may also impact the deferred tax expense. Such deferred tax assets and liabilities that arise in connection with the transaction should be taken into account in the computation of Adjusted Covered Taxes under Article 4.1 to the extent gain or loss on those transactions is included in the computation of GloBE Income or Loss.

Article 6.1 - Application of Consolidated Revenue Threshold to Group Mergers and Demergers

19. As set out in Article 1.1, the GloBE Rules apply to MNE Groups with consolidated revenue of EUR 750 million or more in at least two of the four Fiscal Years immediately preceding the tested Fiscal Year. Article 6.1 complements this four-year revenue test in three scenarios:

- a. where two or more Groups merge to form a single Group;
- b. where a single Entity acquires another Entity or a Group, or vice versa (referred to as a “merger” for GloBE purposes); and
- c. where an MNE Group within the scope of the GloBE Rules demerges into two or more Groups.

20. In the first scenario, the recently merged MNE Group does not have a single consolidated revenue because each of the Groups had their own separate Consolidated Financial Statements. In the second scenario, it is possible that the target or acquirer does not have any Consolidated Financial Statements because it may not have been part of a Group prior to the merger, even though that Entity could have had revenue of EUR 750 million or more in the preceding Fiscal Years that would have been sufficient to bring it within the scope of the rules if it had been part of a Group in those prior years. The last scenario deals with an MNE Group that was in the scope of the GloBE Rules but then is split into separate Groups raising the issue of how to apply the consolidated revenue threshold to these separate Groups following the demerger.

Article 6.1.1

Paragraph (a) – Merger between two or more Groups

21. Article 6.1.1(a) applies where two or more Groups merge into a single Group. Given that the Groups were separate and not part of a merged Group in prior years, the question arises as to how the consolidated revenue threshold is to be applied under these circumstances.

22. Paragraph (a) answers this question by deeming the revenue threshold to be met in a given preceding year if the sum of the revenue included in each Group's Consolidated Financial Statements for that year is equal to or greater than EUR 750 million. Neither Group's pre-merger revenues are adjusted for transactions that occurred between the Groups in the preceding years, notwithstanding that transactions between Entities will be eliminated in consolidation after the merger. This determination has to be made for each of the Fiscal Years that are tested under the consolidated revenue test in Article 1.1.

23. For instance, assume that A Group and B Group reported separately consolidated revenue of EUR 400 million, EUR 300 million, EUR 300 million and EUR 400 million each for years 1 to 4 respectively. The A Group and B Group merge in year 5 into the AB MNE Group. Under these facts, the AB MNE Group is subject to the GloBE Rules in year 5 because in two of the four preceding Fiscal Years the sum of their consolidated revenue included in each of their Consolidated Financial Statements was EUR 750 million or more (i.e. in year 1, the combined revenue was of EUR 800 million and in year 4, the combined revenue was of EUR 800 million).

Paragraph (b) – Merger between two or more Entities, or an Entity and a Group.

24. Paragraph (b) addresses two general scenarios that are referred to as a “merger” for GloBE purposes:

- a. where two single Entities that are not part of a Group are brought together to form a Group and, prior to this merger, only individual (i.e. not consolidated) financial statements were prepared by these entities; and
- b. where a single Entity that does not prepare consolidated financial statements becomes part of a Group.

25. Paragraph (b) also applies where as part of the same arrangement, two or more Groups merge with one Entity; one Group merges with two or more Entities; and two or more Groups merge with two or more Entities.

26. Paragraph (b) contains two parenthetical labels – target and acquirer – that are intended solely to facilitate the drafting of a complex sentence. It would be incorrect to read the sentence as applying only where an Entity that is not a member of any Group is acquired by another Entity or a Group. The paragraph also applies when an Entity that is not a member of a Group acquires another Entity or a Group. Thus, the acquisition of an MNE Group that was already subject to the GloBE Rules by a stand-alone Entity does not re-start the four-year period for purposes of the revenue threshold on the basis that the UPE of the “new Group” does not have Consolidated Financial Statements for previous years.

27. Paragraph (b) modifies the application of the consolidated revenue threshold in both of these cases by aggregating the combined revenue of the Entity(ies) and Group(s) of a given year for purposes of the four-year revenue test. In the case of two single Entities that come together to form a Group, the revenue of each Entity (as reflected in the financial statements of each of the Entities for the prior Fiscal Years) is aggregated for the purposes of applying the consolidated revenue threshold. In the case of an Entity that joins a Group, the revenue included in that Entity's financial statements for a given year must be added to the consolidated revenue of the Group for the same year. If the previous fiscal periods do not align, the revenues of the Fiscal Years should be combined by taking the revenues of fiscal periods that end with or

within the fiscal period that the Group uses after the Entities come together. For example, an MNE Group that uses a calendar year as its Fiscal Year acquires, on 1 January 2023, an Entity that uses a fiscal period that ends on 30 September as its Fiscal Year. The MNE Group continues to use the calendar year as its Fiscal Year after the acquisition. In this scenario, the revenues of the acquired Entity for the Fiscal Years ending 30 September 2022, 2021, 2020, and 2019 are combined with the revenues of the MNE Group for the four preceding Fiscal Years ending 31 December 2022, 2021, 2020, and 2019. The Entity's revenues for the period between 1 October 2022 and 31 December 2022 (which would have been included in the financial statements of that Entity in the following year if it was not acquired) are not included in the computation of the MNE Group's revenue for the calendar years 2022 or 2023.

28. As with paragraph (a), the deeming rule in paragraph (b) is applied to each of the four Fiscal Years prior to the tested Fiscal Year in order to determine whether the newly formed Group falls within the scope of the GloBE Rules. This means that if the combined revenue in two out of the four Fiscal Years prior to the tested Fiscal Year equals or exceeds EUR 750 million, then the consolidated revenue threshold in Article 1.1 is met and the MNE Group is subject to the GloBE Rules in the tested Fiscal Year. In practice, this rule is irrelevant where the acquiring MNE Group meets the revenue threshold under Article 1.1 in the Fiscal Year in which the merger takes place.

29. The following example illustrates the first scenario. Assume from Fiscal Years 1 to 4, A Co and B Co (located in different jurisdictions) were single Entities and that A Co reported revenue of EUR 600 million and B Co reported revenue of EUR 400 million in each of those years. In Fiscal Year 5, A Co acquires B Co, creating a Group and an MNE Group which reports a consolidated revenue of EUR 1 billion in its Consolidated Financial Statements of Fiscal Year 5. In this case, the recently formed AB Group is required to apply the GloBE Rules in Year 5 (i.e. the tested Fiscal Year) because their combined revenue met the EUR 750 million threshold in at least two of the prior 4 Fiscal Years.

30. The next example illustrates the second scenario addressed by paragraph (b). Assume A Group reported consolidated revenue of EUR 500 million in each of Fiscal Years 1 to 4. In Fiscal Year 5, A Group acquired an Entity with reported revenue of EUR 800 million in each of Fiscal Years 1 to 4. In this case, the consolidated revenue threshold is met for Fiscal Year 5 (i.e. the tested Fiscal Year) because the A Group is deemed to have met the EUR 750 million consolidated revenues test by virtue of the acquired Entity's revenue of EUR 800 million in at least two of the preceding four years.

Paragraph (c) – Demerger

31. Paragraph (c) covers the case where an MNE Group demerges into two or more Groups during a Fiscal Year. This paragraph applies where the MNE Group is within the scope of the GloBE Rules in the Fiscal Year that the demerger takes place. Paragraph (c) applies irrespective of the form of the demerger provided that it falls within the definition of a demerger in Article 6.1.3. Paragraph (c) is applied separately to each of the demerged Groups.

32. The rule in paragraph (c) is different from the rules in the previous paragraphs. Paragraphs (a) and (b) complement Article 1.1 by determining the amount of consolidated revenue for each of the four Fiscal Years prior to the tested Fiscal Year. Paragraph (c), in contrast, is a standalone revenue threshold test that applies in addition to the test in Article 1.1.1. The rules in paragraph (c) are intended to ensure that each Group resulting from the demerger of the in-scope MNE Group, that meet the revenue threshold in the Fiscal Year ending after the demerger, remain subject to the GloBE Rules even if the demerged Group does not meet the requirements of Article 1.1 in that year.

33. Paragraph (c) is divided into two subparagraphs. Subparagraph (i) covers the first tested Fiscal Year after the demerger, while subparagraph (ii) covers from the second to the fourth tested Fiscal Years after the demerger. The rules apply separately to each of the Groups that were formed from or remained following the demerger (each, a demerged Group).

First year following the demerger

34. Under subparagraph (i), the consolidated revenue threshold set out in Article 1.1 is deemed to be met by a demerged Group if the demerged Group has annual revenues of EUR 750 million or more in the first tested fiscal year after the demerger. This means that instead of applying a test that considers previous fiscal years, this rule is triggered for each demerged Group that has annual revenues of EUR 750 million or more in the Fiscal Year that is being tested. Note that this paragraph only applies to demerged Groups. The sale of a controlling interest in a single Entity will therefore not fall within the scope of paragraph (c).

35. Sub-paragraph (i) applies to a Group in the Fiscal Year “ending after the demerger”. For example, Assume Group A has a Fiscal Year that is the same as the calendar year. The UPE of Group A distributed all of the shares of subgroup B to its shareholders in 30 June of Year 1. This distribution will be considered a demerger under Article 6.1.3 and result in the creation of Group B. The Fiscal Year of Group A ends on the 31 of December of Year 1. In this case, paragraph (i) tests Group A’s consolidated revenue for Year 1 because it is the first tested Fiscal Year that ends after the demerger. Paragraph (i) also tests Group B’s consolidated revenue for its first tested Fiscal Year that ends after the demerger. Thus, if Group B adopts or retains the calendar year as its Fiscal Year, paragraph (i) will apply to its Fiscal Year ending 31 December of Year 1 because that is Group B’s first tested year that ends after the demerger. However, because Group B’s first tested Fiscal Year is composed of a period other than 12 months, then the EUR 750 million threshold has to be adjusted proportionally consistent with Article 1.1.2.

Second and subsequent years following demerger

36. Paragraph (ii) provides the rule for the second to fourth tested Fiscal Years after a demerger. It states that the consolidated revenue threshold set out in Article 1.1 is deemed to be met by a demerged Group if it has annual revenues of EUR 750 million or more in at least two Fiscal Years following the demerger. As for paragraph (i), this rule takes into account the annual revenue of the Fiscal Year that is being tested. For example, a demerged Group meets the test in the second Fiscal Year (i.e. the tested Fiscal Year), if it has consolidated revenues of EUR 750 million or more in Fiscal Years 1 and 2 following the demerger.

Article 6.1.2.

37. Article 6.1.2 sets out the definition of merger that is used in applying the rules in Article 6.1.1. The definition of “merger” applies only for the purposes of Article 6.1.1 and is broader than the commonly understood meaning of merger. The term applies to any merger or acquisition transaction that results in all or substantially all of the Entities of the two or more Groups being brought under common control. Article 6.1.2 is divided into two paragraphs with two different definitions. The rule in Article 6.1.1 (a) or (b) will apply if either one of the definitions in Article 6.1.2 applies.

Paragraph (a)

38. Paragraph (a) states that a merger is an arrangement in which all or substantially all of the Group Entities involved are brought under common control to form a combined Group. The form of the merger transaction is not relevant for purposes of paragraph (a) as long as the common control conditions are met. For example, it applies where a Group is acquired by another Group in an all-cash transaction or where two separate Groups are brought under the control of a new UPE. The definition requires that “all or substantially all” of the Entities that are the members of the separate Groups become members of the merged Group. It would not apply, for example, where a Group sells all the Entities that make a business division unless that division represented virtually all the business of the selling Group.

Paragraph (b)

39. Under paragraph (b), a merger includes an arrangement where a single Entity (which is not a member of any Group) is brought under common control with another single Entity or Group such that it creates a combined Group. This definition is relevant for purposes of Article 6.1.1 (b) as it covers the situation in which a standalone Entity acquires another standalone Entity to become a Group for the first time. It also encompasses the situation in which a single Entity acquires a Group, and where a Group acquires an Entity that is not part of another Group.

40. Paragraphs (a) and (b) both require the creation of a new “combined Group”. The definition of the term “Group” under Article 1.2.2 has to be taken into account for determining whether a new Group is formed. For example, the definition is not met where two Groups were acquired by an Investment Fund that is not required to consolidate them on a line-by-line basis. In this case, the Investment Fund and the two Groups do not form a “combined Group” because the assets, liabilities, income, expenses and cash flows of their Entities are reported under different Consolidated Financial Statements.

Article 6.1.3.

41. Article 6.1.3 defines the term “demerger” for purposes of Article 6.1.1(c). A demerger is defined as any arrangement where the Group Entities of a single Group are separated into two or more standalone Groups. After a demerger, the disposed Group Entities are no longer consolidated on a line-by-line basis by the same UPE but continue to be consolidated on a line-by-line basis by two or more UPEs of different MNE Groups from the date of the demerger.

42. This definition relies on the consolidation test and the definition of a Group included in Articles 1.2.2 and 1.2.3. Therefore, whether a Group is separated into two or more Groups depends on whether each separated collection of Entities meets the definition of a Group and has its own Consolidated Financial Statements as defined by Article 10.1.

43. As a general rule, the disposal of a single Constituent Entity is not a demerger because after the disposal it would become a standalone Entity and not a Group. However, where the disposed Constituent Entity has a PE in another jurisdiction, then the standalone Entity and its PE are considered a Group in accordance with Article 1.2.3 and therefore, a new Group would exist for the purposes of Article 6.1.3. This definition does not cover the situations in which an MNE Group disposes of one or more Constituent Entities and the acquirer is another Group. In these cases, the disposed Entities are joining an existing Group, not creating a new one. A sale of one or more Constituent Entities to another MNE Group may, however, fall within the definition of a merger in Article 6.1.2(a) or (b) with respect to the acquiring MNE Group, where, for example, the sale of those Entities represented virtually all the business of the selling Group.

Article 6.2 - Constituent Entities joining and leaving an MNE Group

44. The GloBE Rules and Commentary are generally drafted on a steady-state basis that assume the MNE Group is comprised of the same Constituent Entities throughout the entire Fiscal Year. When an acquisition or disposition of a Controlling Interest in a Constituent Entity (referred to in Article 6.2 as the target) takes place during the Fiscal Year, Article 6.2 modifies or clarifies the operation of the GloBE Rules in order to ensure the appropriate outcomes for both the buyer and seller. The rules are intended to produce a smooth separation of the target from the seller Group and a smooth integration of the target into the acquiring MNE Group. Article 6.2.1 includes provisions that apply in the Fiscal Year the Entity leaves or joins the Group (i.e. the acquisition year) as well as rules that apply for the purposes of determining the ongoing tax attributes of an Entity that joins the Group in the years following the acquisition year. In relation to a target, it addresses the question of when the target is treated as joining or leaving a Group and

apportions its income and expenses, including its Covered Taxes, between the Groups for the purposes of the GloBE Rules.

45. Article 6.2 also provides a special ordering rule for applying the IIR where the target is a Parent Entity that is required to apply the IIR as a member of one or both MNE Groups. Special rules are required to determine whether a target should apply the IIR for all or part of the year because the application of the IIR by the target depends on whether a Controlling Interest in the target is held by a Group Entity that is subject to a Qualified IIR. Specific ordering rules are not required for the application of the UTPR in these cases because the impact of a Constituent Entity leaving or joining an MNE Group is automatically taken into account as part of the allocation methodology of the UTPR. The allocation of top-up tax under the UTPR is discussed further in the Commentary on Article 2.6.

46. Under Article 6.2.2, if a transfer of a Controlling Interest in a Constituent Entity is treated as a transfer of assets and liabilities rather than a transfer of Ownership Interests by the jurisdiction where the target is located, then it will be treated as a transfer of assets and liabilities for GloBE purposes as well. In that case, the rules in Article 6.3 apply.

Article 6.2.1

47. The rules of Article 6.2.1 apply to all Constituent Entities that leave or join an MNE Group as a result of a direct or indirect disposition or acquisition of a Controlling Interest in that Entity. Accordingly, the term “target” as used in the Commentary to this Article refers to all such Entities.

Paragraph (a)

48. Paragraph (a) confirms that the target will be treated as a Constituent Entity of both the acquiring and disposing MNE Group notwithstanding that its financial performance for the entire Fiscal Year is not consolidated on a line-by-line basis. Paragraph (a) follows the accounting treatment such that if any portion of the target’s assets, liabilities, income, expenses and cash flows are included in the UPE’s Consolidated Financial Statements in the acquisition year, then it will be treated as a member of the MNE Group for that year. In practice, if an MNE Group disposes a Controlling Interest in a Constituent Entity during a Fiscal Year, it is likely that a portion of its income and expenses would be included in the Consolidated Financial Statements of the disposing MNE Group based on the period in which the Constituent Entity was a member of the Group. Similarly, it is likely that all of the Constituent Entity’s assets and liabilities would be included in the Consolidated Financial Statements of the acquiring MNE Group and a portion of its income, expenses, and cash flows would be included based on the period in which the Constituent Entity was a member of the Group. The remaining paragraphs of Article 6.2 set out specific rules designed to ensure an equitable apportioning of tax outcomes and tax attributes between the two MNE Groups.

Paragraph (b)

49. Paragraph (b) states that in the acquisition year, the amount of Financial Accounting Net Income or Loss and the amount of Adjusted Covered Taxes taken into account for calculating a GloBE tax liability for each MNE Group, shall be the amount that is taken into account in the Consolidated Financial Statements of each MNE Group. This approach follows the general approach adopted by the GloBE Rules of relying on the amounts reflected in the financial accounts that are used for the preparation of the Consolidated Financial Statements.

Paragraph (c)

50. Under Article 6.2.1(c), an MNE Group that acquires a Controlling Interest in a Constituent Entity will ignore the effect of any purchase accounting consolidation adjustments attributable to the acquisition and treat the acquired target, for GloBE purposes, as having the same carrying value in its assets that it

has prior to the transfer (i.e. the historical carrying value). In other words, the acquisition of a Controlling Interest in a target does not result in any change to the carrying value of the target's assets and liabilities for the purposes of determining GloBE Income or Loss. Moreover, any adjustment to the carrying value of intangible assets that results from the acquisition, such as goodwill, customer lists, or workforce-in-place, are ignored in the computation of GloBE Income or Loss. Denying a step-up in the target's inside basis in its assets and liabilities matches the treatment of the seller and purchaser under the GloBE Rules and ensures that gains or losses on the assets and liabilities of a Constituent Entity are not permanently excluded from taxation under the GloBE Rules by virtue of a transfer of its Ownership Interests. Paragraph (c) is also expected to align outcomes under the GloBE rules with those provided under the domestic laws of most Inclusive Framework jurisdictions and avoid potential differences in treatment across financial accounting standards.

51. This rule is consistent with the prohibition on taking into account purchase accounting adjustments in the computation of GloBE Income or Loss under Article 3.2 and applies irrespective of whether the Controlling Interest was acquired before or after the applicability date of the GloBE Rules. Where the financial accounting standard used by the UPE in preparing its Consolidated Financial Statements permit the UPE to "push down" adjustments to the carrying value of assets and liabilities that were attributable to a purchase of a business to the separate accounts of the acquired Constituent Entity, the Constituent Entity may use the carrying value reflected in its separate accounts if the acquisition occurred prior to 1 December 2021 and the MNE Group does not have sufficient records to determine its Financial Accounting Net Income or Loss with reasonable accuracy based on the unadjusted carrying values of the acquired assets and liabilities. In such cases, however, the Constituent Entity must also take into account any deferred tax assets and liabilities arising in connection with the purchase in the computation of its Financial Accounting Net Income or Loss and its Adjusted Covered Taxes.

Paragraph (d)

52. The Substance-based Income Exclusion is computed for each Constituent Entity under Article 5.3 by aggregating a percentage of Eligible Payroll Costs and Eligible Tangible Assets. Paragraphs (d) and (e) adjust the determination of Eligible Payroll Costs and Eligible Tangible Assets in the case of a target that is acquired or disposed part way through the Fiscal Year. Without such a rule, the Substance-based Income Exclusion calculated for the acquiring and disposing MNE Groups could take into account expenses and costs that were incurred prior to, or after, the target was a member of the MNE Group, possibly duplicating the effect of the expenses and costs.

53. Paragraph (d) states that the amount of Eligible Payroll Costs referred in Article 5.3.3 shall be adjusted by taking into account only the costs that are reflected in the Consolidated Financial Statements prepared by the UPE of the MNE Group. Thus, each MNE Group takes into account the Eligible Payroll Costs arising during its period of ownership and that it bears economic responsibility for.

Paragraph (e)

54. Paragraph (e) provides that the amount of the Eligible Tangible Assets referred in Article 5.3.4 shall be adjusted proportionally to correspond to the length of the period during the Fiscal Year that the target was a Constituent Entity of the MNE Group. The carrying value of the Eligible Tangible Assets is determined based on the amount recorded for the purpose of preparing the Consolidated Financial Statements, including any purchase accounting consolidation adjustments attributable to the acquisition. This means that the acquisition of a Controlling Interest in a target will result in a step-up in a target's inside basis in its assets for the purposes of the Substance-based Income Exclusion, notwithstanding that it does not produce a similar step-up for the purposes of calculating GloBE Income or Loss. The difference in treatment between paragraphs (d) and (e) can be explained on the grounds that the tangible asset carve-out is based on the economic cost of the investment made by the MNE Group in the tangible asset located

in the relevant jurisdiction which is more accurately determined by looking to the fair value of that asset at the time of acquisition than the historical cost of that asset as recorded by the target.¹

Paragraphs (f) and (g)

55. Paragraph (f) generally provides that deferred tax assets and liabilities of a Constituent Entity that are transferred between MNE Groups are taken into account by the acquiring MNE Group in the same manner and to the same extent as they would have been taken into account if the acquiring MNE Group had controlled the Constituent Entity when they arose. Thus, if the acquiring MNE Group acquires a deferred tax liability that qualifies as a Recapture Exception Accrual, Article 4.4.4 does not apply to that deferred tax liability. On the other hand, if the deferred tax liability does not fall within the Recapture Exception Accruals, it will be subject to recapture under Article 4.4.4, after taking into account the rule in paragraph (g) related to the recapture period for acquired deferred tax liabilities. Whether a deferred tax asset or liability is transferred depends on its treatment under the applicable financial accounting standard. This accounting treatment will depend in large part on how the tax laws of the jurisdiction allocate the relevant items of deferred income and expense between the disposing and acquiring MNE Groups.

56. The exception to paragraph (f) is the GloBE Loss Deferred Tax Asset. Ordinary deferred tax assets and liabilities arise with respect to specific Constituent Entities and are accounted for accordingly. They feed into the computation of the Constituent Entity's Total Deferred Tax Adjustment Amount under Article 4.4.1. A GloBE Loss Deferred Tax Asset, on the other hand, arises in connection with a GloBE Loss Election under Article 4.5 with respect to a particular jurisdiction. It is an attribute that arises pursuant to an election under the GloBE Rules, but is not found in the Constituent Entity's or the MNE Group's financial accounts. Because the GloBE Loss Deferred Tax Asset arises in respect of a Net GloBE Loss in a particular jurisdiction of the MNE Group that makes the election, it is considered a jurisdictional attribute of the electing MNE Group, rather than an attribute of the Constituent Entities located in the jurisdiction and cannot be transferred to another MNE Group. Accordingly, Article 6.2.1(f) does not apply to a GloBE Loss Deferred Tax Asset.

57. Paragraph (g) is intended to relieve the disposing MNE Group of the need to recapture deferred tax liabilities that do not reverse (through payment or otherwise) within the five-year period required by Article 4.4.4. This is achieved by treating any deferred tax liability of a Constituent Entity that leaves an MNE Group as reversed when the Entity leaves the MNE Group. The paragraph also starts, or re-starts the five-year period in Article 4.4.4 with respect to deferred tax liabilities of a Constituent Entity when it joins an MNE Group. By re-starting the five-year period in Article 4.4.4, paragraph (g) reduces compliance and administrative burdens that would arise if the deferred tax liabilities were subject to recapture based on their accrual dates in the disposing MNE Group. Thus, a Constituent Entity that leaves one MNE Group and joins another MNE Group will not be required to recapture any deferred tax liabilities under Article 4.4.4 when it leaves the first MNE Group and will start a new five-year period under Article 4.4.4 for all of its deferred tax liabilities when it joins the second MNE Group. Paragraph (g) does not apply to Recapture Exception Accruals described in Article 4.4.5 because they are not subject to the requirements of Article 4.4.4 before or after the acquisition date.

58. Paragraph (g) also modifies the process for handling deferred tax liabilities that do not reverse within the five-year period after the date of acquisition. This is necessary because the normal rule under Article 4.4.4 invokes the procedures of Article 5.4.1, which requires a re-calculation of the ETR and Top-up Tax for the year in which the liability first accrued. The acquiring MNE Group did not perform an original calculation of the ETR and Top-up Tax for the relevant year based on the deferred tax liabilities of the acquired Constituent Entity and thus Article 5.4.1 does not function properly in this context. Accordingly, when an acquired deferred tax liability fails to reverse before the end of the fifth Fiscal Year after the acquisition date, paragraph (g) reduces Covered Taxes in that Fiscal Year. To the extent Covered Taxes

in a jurisdiction in that Fiscal Year are negative as a result of this reduction, Additional Current Top-up Tax may result from the application of Article 4.1.5 if the other conditions for applying Article 4.1.5 are met.

59. As explained at the beginning of this chapter, deferred tax assets and liabilities arising in connection with a business combination generally are not taken into account under the GloBE Rules because the purchase accounting adjustments to the carrying value of assets and liabilities are not taken into account in the computation of GloBE Income or Loss (subject to exceptions for Articles 6.2.2, 6.3.1, 6.3.3, and 6.3.4 noted in the discussion of purchase accounting at the beginning of this chapter).² Where the deferred tax assets and liabilities arising in connection with a business combination are not taken into account under the GloBE Rules, the deferred tax assets and liabilities referred to in Article 6.2.1 (f) and (g) refer to the deferred tax assets and liabilities of an acquired Constituent Entity that existed before the Constituent Entity joined the MNE Group, i.e. pre-acquisition deferred tax assets and liabilities.

60. However, in any case where the adjusted carrying value of assets and liabilities is used for purposes of determining the GloBE Income or Loss, any deferred tax assets and liabilities arising in connection with the acquisition of those assets and liabilities should be taken into account under the GloBE Rules. In such cases, deferred tax liabilities are treated as arising in the Fiscal Year that includes the acquisition date for purposes of applying Article 4.4.4. Deferred tax liabilities that meet the definition of a Recapture Exception Accrual in Article 4.4.5 will not be subject to recapture under Article 4.4.4. The exception in Article 4.4.5(e) for deferred tax liabilities in respect of fair value accounting on unrealised net gains, however, does not provide a blanket exception for deferred tax liabilities attributable to a business combination. That exception applies to deferred tax liabilities in respect of unrealised net gains on assets and liabilities that are regularly accounted for using a fair value method, such as marketable securities. Thus, if a deferred tax liability arises in respect of a purchase accounting adjustment to the carrying value of an asset or liability that will be accounted for using a fair value method after the transaction, Article 4.4.5(e) applies to that deferred tax liability. However, if the deferred tax liability arises in respect of inventory that is accounted for using a cost method or a marketing intangible asset, the deferred tax liability does not qualify as Recapture Exception Accrual.

Paragraph (h)

61. Paragraph (h) deals with the situation in which the target is required to apply the IIR as a Parent Entity of one or both MNE Groups. Paragraph (h) provides that the target shall apply the IIR separately to its Allocable Shares of the Top-up Tax of LTCEs determined for each MNE Group. Thus, this rule applies where the target has an Ownership Interest in an LTCE and is a Parent Entity required to apply the IIR under the top-down approach or split-ownership rules applicable to one or both MNE Groups.

62. The determination of whether a Constituent Entity in which the target has an Ownership Interest is an LTCE must be made separately with respect to both the MNE Group that the target left and the MNE Group that the target joined. Whether a Constituent Entity in which the target has an Ownership Interest is an LTCE is determined based on jurisdictional blending which means that the taxes and income of other Constituent Entities owned by each MNE Group that are located in the same jurisdiction as the target will impact on the jurisdictional ETR and therefore whether the target is considered to have an Ownership Interest in an LTCE. In fact, the same Constituent Entity could be an LTCE of the disposing MNE Group but not an LTCE of the acquiring MNE Group, or vice-versa. This could occur, for example, because one MNE Group has high-taxed Constituent Entities located in the same jurisdiction sheltering the low-tax outcome of the target. This outcome is consistent with the policies or principles underlying the GloBE Rules because the tax attributes of the Constituent Entities would be subject to two different computations for each of the MNE Groups involved.

63. Similarly, whether the target is a Parent Entity required to apply the IIR must be determined based on the facts of each MNE Group. If the target is an Intermediate Parent Entity and the UPEs of the MNE Groups involved are located in a jurisdiction with a Qualified IIR, the target would not be required to apply

the IIR under Article 2.1.3(a). However, if only one of the UPEs is located in a jurisdiction with a Qualified IIR, then the target may be required to apply the IIR with respect to the MNE Group whose UPE is not subject to the IIR. Stated differently, Article 2.1.3(a) deactivates the IIR applicable to the target in the case of the MNE Group whose UPE is subject to a Qualified IIR, but not in the case of the MNE Group whose UPE is not subject to a Qualified IIR. If both UPEs are not located in a jurisdiction with a Qualified IIR, then the target may be required to apply the IIR with respect to each MNE Group based on its Allocable Share of the Top-up Tax, if any, computed with respect to the LTCE by each MNE Group.

Article 6.2.2

64. Article 6.2.2 provides for an exception to Article 6.2.1 aimed at providing consistent treatment of an acquisition and disposition of assets and liabilities for GloBE purposes, regardless of the form in which the transaction is undertaken. When Article 6.2.2 applies to a transaction, the seller is treated as selling its Ownership Interests and the gain or loss on that sale is excluded from Article 3.2.1(c) in the jurisdiction in which it is located. At the same time, the target is treated as selling its assets and liabilities to the acquiring MNE Group in exchange for the consideration received by the seller in a transaction that is subject to Article 6.3.1. The target's gain or loss and Covered Taxes on the sale of its assets and liabilities are taken into account in computing its GloBE Income or Loss and Adjusted Covered Taxes and the disposing MNE Group's ETR for the target's jurisdiction for the Fiscal Year that includes the acquisition date. As a result of this treatment the gain or loss on the transfer that is treated as a sale of assets and liabilities of the target are included in the disposing MNE Group's ETR computation for the jurisdiction that imposed that treatment for local tax purposes, rather than the jurisdiction of the seller of the Ownership Interests.

65. Article 6.2.2 applies to an acquisition (or disposition) of a Controlling Interest where the jurisdiction of the target Constituent Entity treats the transaction as an acquisition and disposition of the underlying assets and liabilities for tax purposes and imposes a Covered Tax on the gain or loss from the deemed disposition of assets by the seller. This provision includes situations where the target jurisdiction imposes a Covered Tax on the seller based on the difference between the tax basis of the assets and the tax amounts of the liabilities and the consideration paid or fair value.

66. A Controlling Interest is acquired when a Constituent Entity that was not in control of the target acquires Ownership Interests that give it control of the target. The rule in Article 6.2.2 does not require the Constituent Entity to acquire all of its Ownership Interests in the transaction in which it gains control. Thus, acquisition of an Ownership Interest, no matter how small, that combined with Ownership Interests already owned by the Constituent Entity may result in the Constituent Entity acquiring a Controlling Interest. Once a Constituent Entity has a Controlling Interest, acquisition of additional Ownership interests in the target are not acquisitions of a Controlling Interest. However, the tax laws of the target's jurisdiction may treat a transaction as a sale of assets only when the control is acquired in a single or series of related transactions.

67. There are two conditions for Article 6.2.2 to apply. The first is that the jurisdiction of the target Constituent Entity treats the transaction as, or similar to, an acquisition or a disposal of the underlying assets and liabilities for tax purposes. This condition includes situations where, on acquisition of a Controlling Interest in the target Constituent Entity, for tax purposes, the jurisdiction of the target Constituent Entity recognises the assets and liabilities of that Constituent Entity as forming part of another Constituent Entity located in that jurisdiction because the target has become a member of a tax consolidated group.

68. The second condition is that the jurisdiction of the target Constituent Entity imposes a Covered Tax on the seller based on the difference between the tax basis of the underlying assets and amount of the underlying liabilities and the consideration received in exchange for the Controlling Interest, or the difference between that tax basis and fair value of the assets and liabilities. The second condition is met in situations where the target jurisdiction imposes a Covered Tax on the seller based on the difference between the consideration received by the seller and the tax basis of the target's underlying assets and

liabilities. The second condition can also be met where the target jurisdiction imposes a Covered Tax on the seller based on the difference between the fair value of the underlying assets and liabilities and the target's tax basis therein. In sum, the Covered Tax must be based on a gain that is determined by reference to the "inside basis" of the target's assets and liabilities.

Article 6.3 - Transfer of Assets and Liabilities

69. Article 6.3 provides rules for the recognition or non-recognition of gain or loss on the disposition of assets and liabilities and for determining the carrying values of assets and liabilities acquired in an ordinary acquisition or disposition and an acquisition or disposition in connection with a GloBE Reorganisation where the seller is not subject to tax on the gain (or loss), in whole or part.

70. Article 6.3.1 provides the general rule applicable to all acquisitions and dispositions of assets and liabilities whether individually or as part of an acquisition or disposition of a business. Articles 6.3.2 and 6.3.3 lay out the provisions applicable to the acquisition and disposition of assets and liabilities as part of a GloBE Reorganisation. Articles 6.3.2, and 6.3.3 apply to both domestic and cross-border transactions that qualify as GloBE Reorganisations under the definition in Article 10.1. The definition of GloBE Reorganisation is discussed in the Commentary to Article 10.1. The provisions of Articles 6.3.1, 6.3.2, and 6.3.3 do not require that a disposing Constituent Entity and an acquiring Constituent Entity belong to the same MNE Group and apply irrespective of whether the counterparty to the transaction is itself a Constituent Entity that is part of an MNE Group subject to the GloBE Rules.

Article 6.3.1

71. Article 6.3.1 relates to an acquisition or disposition of assets and liabilities that is not part of a GloBE Reorganisation. The Article follows the accounting treatment for both the disposing Entity and the acquiring Entity. Financial accounting rules generally recognise a seller's gain or loss on the disposition of assets and liabilities and require the acquirer to use the acquisition price, which is generally the fair value of the assets, to measure the assets and liabilities upon its acquisition. As such, for GloBE purposes, the disposing Entity must include gain or loss from the disposition of assets and liabilities in its computation of GloBE Income or Loss and the acquiring Entity must use the adjusted carrying value as determined under the financial accounting standard used in preparing the Consolidated Financial Statements of the UPE.

72. In a transfer to which Article 6.2.2 applies, the carrying value of the acquired assets and liabilities for GloBE purposes is based on their fair value to the extent gain or loss on those assets and liabilities was included in the GloBE Income or Loss computation of the selling MNE Group. The fair value must be used in the computation of the acquiring Entity's computation of GloBE Income or Loss in the acquisition year and subsequent Fiscal Years irrespective of whether the fair value adjustments are reflected in the Entity's financial accounts or the MNE Group's consolidated financial accounts.

73. The acquiring Entity may be required under the applicable accounting standard to recognise assets and liabilities that were not recognised in the financial accounts of the disposing Entity, such as goodwill or other intangible assets. In addition, the acquiring Entity may be required to recognise bargain purchase gains under the applicable accounting standard. In such cases, amortisation of the intangible assets or the bargain purchase gain will be included in the computation of GloBE Income or Loss only to the extent included in the acquiring Entity's Financial Accounting Net Income or Loss.

Article 6.3.2

74. Articles 6.3.2 sets out the general treatment of an acquisition or disposition of assets and liabilities as part of a GloBE Reorganisation. Article 6.3.2 aligns the GloBE Rules with the tax deferral treatment of reorganisations under domestic provisions. The requirements to qualify as a GloBE Reorganisation in

paragraphs (b) and (c) of the definition relate to the tax treatment of the transformation or transaction under local tax law. These paragraphs consider the tax treatment of the transferor/dispersing and transferee/acquiring entities and both paragraphs must be met for the transaction to qualify as a GloBE Reorganisation. Consistent treatment of the transferor/dispersing and transferee/acquiring entities will ordinarily occur in a purely domestic transformation or transaction and may occur in a cross-border transformation or transaction. However, consistent treatment will not always occur in a cross-border transformation or transaction.

75. Article 6.3.2(a) provides that the dispersing Constituent Entity will not recognise the gain or loss from the transfer of the assets and liabilities for GloBE purposes. Pursuant to Article 6.3.2(b) future profit or loss of the acquiring Constituent Entity will be determined on the basis of the historical carrying amounts of the acquired assets and liabilities. The Constituent Entity must maintain accounting records to support the computation of GloBE Income or Loss by reference to the historical carrying amounts of the acquired assets and liabilities.

Article 6.3.3

76. Article 6.3.3 addresses instances where a GloBE Reorganisation results in the recognition of Non-qualifying Gain or Loss under the laws of the dispersing Entity's jurisdiction. This may be the case under tax rules in Inclusive Framework jurisdictions, for example, where there is a limit to the amount of non-equity consideration that can be paid as part of the consideration for the transaction to qualify as a GloBE Reorganisation. Amounts paid over that limit may constitute taxable consideration that triggers the recognition of a gain or loss in respect of the assets transferred pursuant to the reorganisation.

77. In the context of such GloBE Reorganisations, Article 6.3.3 provides that the dispersing Constituent Entity will include a gain or loss to the extent of the Non-Qualifying Gain or Loss. This means that the computation of GloBE Income or Loss will include the lesser of the amount of gain or loss reflected in the financial accounts or the amount of the taxable gain or loss arising from the GloBE Reorganisation. Further, the acquiring Constituent Entity will increase or decrease the carrying amounts of the acquired assets and liabilities to account for the Non-qualifying Gain or Loss. The changes in carrying value for GloBE purposes must be allocated among assets and liabilities in a manner consistent with the increases and decreases of those assets under the tax law applicable to the acquiring Constituent Entity. For example, if the Constituent Entity is required by local tax rules to allocate the basis increases due to the tax gain, first to depreciable assets up to the amount of built-in gain on such assets, and then to inventory and other current assets, the Constituent Entity must do the same for GloBE purposes. However, the increase or decrease in carrying value of assets and liabilities for GloBE purposes cannot exceed the Non-qualifying Gain or Loss.

Article 6.3.4

78. A Constituent Entity may be required or permitted to adjust the tax basis of its assets or the tax amount of its liabilities for a variety of reasons. Perhaps the most common circumstance is where a Constituent Entity is subject to an exit tax because of a cross-border reorganisation or a change in the Entity's tax residence. In addition, a Constituent Entity may be required to adjust the tax basis or amount of some or all of its assets and liabilities when it joins or leaves a tax consolidated group. In other cases, the Constituent Entity (or its owners) may be permitted to make an election that adjusts the tax basis of assets and tax amount of liabilities. The adjustments required by these local tax rules are usually, but not always, based on the fair value of the asset or liability.

79. Article 6.3.4 provides an MNE Group with an election for these situations which seeks to align the outcomes under GloBE with those that apply under local tax law. When an election under Article 6.3.4 is made, the Constituent Entity recognises gain or loss and adjusts the carrying value of its assets and

liabilities for purposes of the GloBE Rules. The election, however, does not apply to ordinary sales of assets (e.g. sales of inventory) by a Constituent Entity or transfer pricing adjustments. Moreover, if an election is made under this Article in connection with the acquisition of a Controlling Interest in a Constituent Entity that is governed by Article 6.2.1, the election does not affect the application of Article 3.2.1(c) to the seller.

80. Under paragraph (a), the gain or loss with respect to each asset or liability to be included in the computation of GloBE Income or Loss is initially determined under sub-paragraph (i) based on the difference between the carrying value for financial accounting purposes of the asset or liability immediately before the date of the event that triggered the tax adjustment (the triggering event), and the fair value of the asset or liability immediately after the triggering event. The carrying value of the asset or liability prior to the triggering event can be calculated by subtracting any depreciation or other valuation adjustment leading up to the trigger event from the carrying value of the asset or liability at the beginning of the Fiscal Year. Where the triggering event is the acquisition of an Ownership Interest in a Constituent Entity, the fair value of all the assets and liabilities of the Constituent Entity will typically be commensurated with the acquisition cost of the Ownership Interest(s). Because the triggering event may occur as a result of, or in connection with, a GloBE Reorganisation, sub-paragraph (ii) reduces (or increases) the amount of gain (or loss) determined under sub-paragraph (i) by the amount of any gain (or loss) already recognised as Non-Qualifying Gain or Loss. Thus, sub-paragraph (ii) prevents duplication of gains and losses that have already been included in the GloBE Income or Loss computation under Article 6.3.3.

81. Pursuant to paragraph (b), the Constituent Entity will use the fair value of the assets and liabilities to compute its GloBE Income or Loss in the Fiscal Years ending after the triggering event. The fair value to be used is the fair value of the assets determined pursuant to the financial accounting standard used in the Consolidated Financial Statements.

82. Under paragraph (c), the net gain or loss on all of the Constituent Entity's assets and liabilities determined under paragraph (a) can be included in the computation of GloBE Income or Loss in the Fiscal Year in which the triggering event occurs or can be spread pro rata over five consecutive Fiscal Years starting with the Fiscal Year in which the triggering event occurs. If the total net gain or loss is spread over five Fiscal Years and the Constituent Entity leaves the MNE Group before the end of the five-year period, the remainder of the gain or loss must be accelerated and taken into account in the Fiscal Year that the Constituent Entity leaves the MNE Group.

Article 6.4 - Joint Ventures

83. A common business practice undertaken by MNE Groups is entering into joint ventures with third parties. Generally, for accounting purposes, a joint venture is a business enterprise that is jointly controlled by two or more persons or Entities. Because the enterprise is not controlled exclusively by one person, its accounting results are not consolidated with any of its owners on a line-by-line basis. Instead, the financial results of joint ventures are commonly reported by MNE Groups using the equity method in their Consolidated Financial Statements. Absent a special rule, this accounting treatment would exclude them from the scope of the GloBE Rules because they do not meet the definition of a Constituent Entity under Article 1.3, which requires an Entity to be consolidated on a line-by-line basis. Thus, if two MNE Groups subject to the GloBE Rules each owned 50% of the Ownership Interests of a joint venture, neither MNE Group would be subject to the GloBE Rules on its share of the JV's income in the absence of Article 6.4.

84. Article 6.4 extends the application of the GloBE Rules to Entities in which the UPE of an MNE Group owns 50% or more of the Ownership Interests (such Entities are JVs under the GloBE Rules). This ensures that all of the income of a 50/50 JV owned, directly or indirectly, by the UPE of an MNE Group will be subject to the GloBE Rules and that the rule extends to any venture in which the MNE Group holds 50% or more of the Ownership Interests (without having unilateral control). Article 6.4 does not, however,

require the JV or its JV Subsidiaries to apply the IIR or the UTPR directly. Rather it requires the MNE Group to determine Top-up Tax in respect of a JV (or its JV Subsidiaries) located in a Low-Taxed Jurisdiction and allocates any resulting Top-up Tax to a Constituent Entity within the MNE Group under the IIR or the UTPR.

Article 6.4.1

85. Article 6.4.1 is a special rule that applies to JVs reported by the MNE Group in their Consolidated Financial Statements. The definition of a JV under the GloBE Rules departs from the one commonly used in accounting rules. A JV is defined in Article 10.1 as an Entity whose financial results are reported under the equity method in the Consolidated Financial Statements of the MNE Group provided that the UPE holds directly or indirectly at least 50% of its Ownership Interests. Thus, an Entity is not a JV under the GloBE Rules, where the UPE holds less than 50% of its Ownership Interests despite that it could still be considered as a JV under accounting rules if it is jointly controlled by the MNE Group. Similarly, an Entity commonly referred to as an “associate” under accounting rules (e.g., IAS 28 (IFRS Foundation, 2022^[21])) and also reported under the equity method typically would not meet the GloBE definition of a JV because the UPE would not reach the 50% ownership threshold. In this latter case, the MNE Group would have significant influence over the Entity instead of joint control, which is a difference between “associates” and JVs under accounting rules.³ However, such factor is not decisive in the GloBE definition of a JV.

86. An Entity is not considered a JV for GloBE purposes if it is an Excluded Entity or the Ownership Interests of the Entity held by the MNE Group are held directly by an Excluded Entity. Furthermore, an Entity is excluded from the definition of a JV if it is a UPE of an MNE Group that is already within the scope of the GloBE Rules because such Group meets the consolidated revenue threshold set out in Article 1.1.

87. Article 6.4.1 also extends the operation of the GloBE Rules to the income of Entities controlled by the JV (JV Subsidiaries). The JV and its JV Subsidiaries make up a JV Group. The members of a JV Group are not required to apply the charging provisions in Chapter 2. However, they are treated as if they were Constituent Entities for purposes of computing their jurisdictional ETR and Top-up Taxes.

88. Article 6.4.1 brings a JV and its subsidiaries into scope of the GloBE Rules but only with respect to the UPE’s share of the JV and its subsidiaries. If the JV is an LTCE, the GloBE Rules would apply similar to the way they apply to Constituent Entities. However, Article 6.4.1 does not require a JV or its JV subsidiaries to apply the IIR or UTPR.

Paragraph (a)

89. Paragraph (a) provides special rules for computing the Top-up Tax of the JV and its JV Subsidiaries. It states that the Top-up Tax of the JV Group shall be computed in accordance with Chapters 3 to 7 and Article 8.2 as if such the members of the JV Group were Constituent Entities of a separate MNE Group and as if the JV was the UPE of that Group. This means that all the provisions included in Chapters 3 to 7 and Article 8.2 of the GloBE Rules related to the computation of the Top-up Tax are applicable to the members of JV Group including the provisions on the Substance-based Income Exclusion and Safe-Harbours. However, the Top-up Tax computation for the JV Group under Chapter 5 is made as if the JV was the UPE of a separate MNE Group. Therefore, for example, the accounting standard used in preparing Consolidated Financial Statements of the JV Group is the accounting standard of the JV (not the UPE) and the GloBE Income or Loss and Covered Taxes of the JV and its JV Subsidiaries are not blended with the Constituent Entities of the wider MNE Group for purposes of the JV’s jurisdictional ETR computations (or the jurisdictional ETR computations of the wider MNE Group). Lastly, the transitional rules in Articles 9.1 and 9.2 also apply with respect to JVs on the grounds that they complement the provisions in Chapters 4 and 5. When an MNE Group computes the jurisdictional ETR of the members of a JV Group it should take into account any Adjusted Covered Taxes recorded in the financial accounts of the Constituent Entities

of such MNE Group with respect to the GloBE Income or Loss of the members of the JV Group in accordance with Article 4.3.

Paragraph (b)

90. Paragraph (b) regulates the application of the IIR by Parent Entities with respect to the Top-up Tax of a JV and a JV Subsidiary. Paragraph (b) only applies to Parent Entities that have Ownership Interest in the JV or the JV Subsidiary. It requires such Parent Entities to apply the IIR in accordance with Articles 2.1 to 2.3. This means that the UPE and other Parent Entities are required to apply the IIR in accordance with the top-down approach and split-ownership rules.

91. The UPE or any other Parent Entity applying the IIR must allocate the Top-up Tax of the JV or JV Subsidiary based on its Allocable Share of the Top-up Tax. For example, assume Hold Co holds 50% of the Ownership Interests of JV Co, a JV as defined by Article 10.1. JV Co owns 80% of the Ownership Interests of Sub Co (a JV Subsidiary as defined by Article 10.1). JV Co and Sub Co are both LTCEs and each one has a Top-up Tax of 100. The UPE's Allocable Share of the Top-up Tax of JV Co is 50 (100 x 50%). The UPE's Allocable Share of the Top-up Tax of Sub Co is 40 (100 x 50% x 80%).

Paragraph (c)

92. Lastly, paragraph (c) describes how the UTPR is applied in the context of JVs. In practice, the UTPR only applies, with respect to a member of a JV Group, where the UPE or other Parent Entities have not brought into charge the JV Group Top-up Tax under a Qualified IIR in accordance with paragraph (b). Paragraph (c) requires the JV Group Top-up Tax to be added to the Total UTPR Top-up Tax Amount, after it has been reduced by the amount that has already been brought into charge under the IIR.

93. The term JV Group Top-up Tax is defined in Article 10.1 as the UPE's Allocable Share of the Top-up Tax of all members of the JV Group. The amount is computed on the basis of the UPE's Allocable Share of the Top-up Tax of the JV or its JV Subsidiaries. For example, assume the UPE holds 50% of the Ownership Interests of JV Co, a JV subject to Article 6.4. JV Co owns 80% of the Ownership Interests of Sub Co (a JV Subsidiary also subject to Article 6.4). JV Co and Sub Co are both LTCEs and each one has a Top-up Tax of 100. The JV Group Top-up Tax is 90 (50 of JV Co's Top-up Tax and 40 of Sub Co's Top-up Tax).

94. If all the Top-up Tax is allocated under paragraph (b), then the JV Group Top-up Tax would be zero and therefore, paragraph (c) has no effect. If there is an amount of Top-up Tax that has not been brought into charge under paragraph (b), then such amount would be added to the Total UTPR Top-up Tax Amount taken into account under Article 2.5.1 so it can be allocated under the UTPR.

Article 6.5 - Multi-Parented MNE Groups

95. Article 6.5 covers the situation in which two or more Groups prepare Consolidated Financial Statements in which the financial performance of these Groups is presented as a single economic unit in accordance with a Dual-listed Arrangement or a Stapled Structure. The rules in this Article ensure that the GloBE Rules apply to these structures in the same way they would apply to a Group with single UPE with an appropriate allocation of Top-up Tax amongst the Constituent Entities of the combined MNE Group. A Multi-Parented MNE Group is comprised of two or more Groups whose UPEs enter into an arrangement that is a Stapled Structure or Dual-listed Arrangement. The terms Multi-Parented MNE Group, Dual-listed Arrangement and Stapled Structure are defined in Article 10.1.

96. The GloBE Rules apply only to MNE Groups and therefore the definition of a Multi-Parented MNE Group requires that at least one Entity or PE of the combined Group has to be located in a different

jurisdiction with respect to the rest of the Entities of the combined Group. The phrase “combined Group” was included in the definition to accommodate the situation in which two domestic Groups hold Ownership Interests of an Entity located in another jurisdiction but they only hold the Controlling Interests of the Entity when they act as a combined Group. For instance, two separate domestic Groups may each hold 50% of the Ownership Interests of an Entity located in another jurisdiction (or domestic Entity with a PE in another jurisdiction). In this case, the Entity would be treated as a JV by each Group individually. However, where the UPEs of both Groups are part of a Stapled Structure or Dual-listed Arrangement the JV becomes a Constituent Entity of the combined Group and because that Entity is located in another jurisdiction, the combined Group becomes a Multi-Parented MNE Group.

97. A Stapled Structure is an arrangement under which 50% or more of the Ownership Interests in the UPEs are “stapled” together as if they were the Ownership Interests of a single Entity. Stapled Ownership Interests are combined together (through their form of ownership, restrictions on transfer, or other terms or conditions) in a way that they cannot be transferred or traded independently. Stapled Ownership Interests that are listed on a securities exchange, are quoted on that exchange at a single price for the combined Ownership Interests. The definition of Stapled Structure also requires that one of the UPEs prepares Consolidated Financial Statements in which assets, liabilities, income, expenses and cash flows of the Entities in all of the Groups are presented together as those of a single economic unit.

98. The other arrangement covered by the definition of a Multi-Parented MNE Group is a Dual-listed Arrangement. A Dual-listed Arrangement is an arrangement whereby two or more UPEs combine their businesses through contract rather than bringing them under the ownership and control of a single entity. Under a Dual-listed Arrangement, each UPE makes distributions to its owners based on a fixed ratio pursuant to a contract, such as an equalization agreement, and the activities of the combined groups are managed collectively as if they were carried out by a single economic entity. As with the definition of Stapled Structure, the definition of Dual-listed Arrangement also requires the UPEs to prepare Consolidated Financial Statements in which the assets, liabilities, income, expenses and cash flows of all the Entities of the Groups are presented together as those of a single economic unit. However, in contrast to Stapled Structures, the Ownership Interests in the UPEs under a Dual-listed Arrangement are quoted, traded or transferred independently in different capital markets.

99. Under these definitions, both a Stapled Structure and a Dual-listed Arrangement must prepare the Consolidated Financial Statements that are externally audited pursuant to a regulatory regime. This requirement is satisfied where a UPE prepares Consolidated Financial Statements in accordance with an Acceptable Financial Accounting Standard where it requires that the Consolidated Financial Statements must present fairly the financial position and performance of the Entities and are audited by a professional external auditor in accordance with the auditing standards issued by the auditing standards board in the jurisdiction of location of the UPE.

Article 6.5.1

100. Article 6.5.1 is divided into several paragraphs, each of which contains a different rule that applies particularly to Multi-Parented MNE Groups.

Paragraph (a)

101. Paragraph (a) states that the Entities and Constituent Entities of each Group are treated as if they were members of a single MNE Group for purposes of the GloBE Rules. This paragraph refers to “Entities” and “Constituent Entities” because it has two objectives. The first objective is determining the composition of the combined Group. Similar to Article 1.2.2, this test refers to all Entities regardless of whether they are Constituent Entities or Excluded Entities. This is important for applying the consolidated revenue threshold in Article 1.1, which takes into account the revenue of Entities that are members of the combined Group regardless of whether they are Excluded Entities. The second objective is to identify the Constituent

Entities of the Multi-Parented MNE Group for the purposes of applying the mechanical provisions of the GloBE Rules. Under this paragraph, the Constituent Entities, including PEs, of each of the Groups are treated as Constituent Entities of a single Multi-Parented MNE Group.

Paragraph (b)

102. Paragraph (b) states that an Entity (other than an Excluded Entity) shall be treated as a Constituent Entity of the Multi-Parented MNE Group if it is consolidated on a line-by-line basis by such Group or its Controlling Interests are held by Entities of such Group. The purpose of paragraph (b) is to extend the definition of Constituent Entity to those Entities that would not meet the definition if each Group were tested separately but that are, nevertheless, included on a line-by-line basis in the Consolidated Financial Statements of the Multi-Parented MNE Group. Furthermore, these Entities are considered as Constituent Entities if they are not consolidated on a line-by-line basis by the Multi-Parented MNE Group but their Controlling Interest are held by Entities of the Multi-Parented MNE Group. For example, MNE Group 1 and MNE Group 2 together constitute a Multi-Parented MNE Group. The UPEs of each MNE Group hold 50% of the Ownership Interests of an Entity. If each MNE Group were treated as a separate Group under the rules, the financial performance of the Entity would have been reported under the equity method and therefore, the Entity would have been treated as a JV. However, given that the Multi-Parented MNE Group collectively holds the Controlling Interests of the Entity it is expected that such Entity would be consolidated on a line-by-line basis and therefore, considered as a Constituent Entity of the MNE Group. In the case that such Entity was not consolidated on a line-by-line basis, it will still be considered as a Constituent Entity because its Controlling Interests are held by Entities of the Multi-Parented MNE Group. The same would apply, for instance, if each MNE Group held 30% of the Controlling Interests of the Entity.

Paragraph (c)

103. Paragraph (c) states that the Consolidated Financial Statements of the Multi-Parented MNE Group are those referred to in the definition of Stapled Structure or Dual-listed Arrangement. Therefore, the Consolidated Financial Statements of the Multi-Parented MNE Group created under a Stapled Structure are those referred in paragraph (b) of the definition of Stapled Structure. Similarly, the Consolidated Financial Statements of the Multi-Parented MNE Group created under a Dual-listed Arrangement are those referred in paragraph (e) of the definition of Dual-listed Arrangement. These statements must meet the definition of Consolidated Financial Statements to be used for purposes of the GloBE Rules. Furthermore, the last part of paragraph (c) clarifies that whenever there is a reference to the accounting standard of the UPE, then it should be deemed to be the accounting standard that has been used by the Multi-Parented MNE Group to prepare its combined Consolidated Financial Statements.

Paragraph (d)

104. Paragraph (d) clarifies that the UPEs of the Groups that comprise the Multi-Parented MNE Group are still considered as the UPEs of the Multi-Parented MNE Group. This clarification is important because it confirms that in these cases there would be more than one UPE. The text in the parenthesis at the end of paragraph (d) further clarifies that any references to the UPE in the GloBE Rules refers to the UPEs of the Multi-Parented MNE Group.

Paragraph (e)

105. Paragraph (e) indicates that the Parent Entities of the Multi-Parented MNE Group shall apply the IIR in accordance with Articles 2.1 to 2.3 with respect to their Allocable Shares of the Top-up Tax of the LTCE. This means that under Article 2.1, each of the UPEs are required to apply the IIR under the top-down approach in the jurisdiction in which they are located. This means that split-ownership rules are also

applicable. However, the determination of whether an Entity is a POPE shall take into account both of the UPEs Ownership Interests in the Entity.

106. For example, MNE Group 1 holds 60% of the Ownership Interests of Sub Co, while the remaining 40% is held by MNE Group 2. Both Groups form part of a Multi-Parented MNE Group. Sub Co holds all of the Ownership Interests of an LTCE. If each MNE Group was assessed separately, Sub Co would have been a POPE of MNE Group 1 under Article 10.1 because more than 20% of its Ownership Interests are held by persons that are not Constituent Entities of MNE Group 1. However, given that MNE Group 1 and MNE Group 2 are considered a single MNE Group, then 100% of Sub Co's Ownership Interests are held by Constituent Entities and therefore, Sub Co does not meet the definition of a POPE. In this case, the UPEs of MNE Group 1 and MNE Group 2 would apply the IIR based on their Allocable Share of the Top-up Tax (60% and 40%, respectively).

107. It is possible that only one of the UPEs of the Multi-Parented MNE Group is subject to a Qualified IIR. In such a case, the application of the top-down approach under Article 2.1.3 will depend on the legal holding structure of the Multi-Parented MNE Group. For example, if all of the Ownership Interests of an Intermediate Parent Entity, that are held by the Multi-Parented MNE Group, are held by the UPE that is subject to a Qualified IIR, then Article 2.1.3 (a) deactivates the obligation of the Intermediate Parent Entity from applying the IIR. However, if both UPEs hold Ownership Interests in the Intermediate Parent Entity, then Article 2.1.3(a) does not apply because one of its UPEs is not subject to a Qualified IIR. In this latter case, the Intermediate Parent Entity is required to apply the IIR based on its Allocable Share of the Top-up Tax of the LTCE and the UPE that is subject to a Qualified IIR would reduce its Allocable Share of the Top-up Tax of the LTCE in accordance with Article 2.3.

108. The computation of each Parent Entity's Allocable Share of the Top-up Tax of LTCEs in accordance with Article 2.2 is not affected by Article 6.5. This also applies to the UPEs of the Multi-Parented MNE Group notwithstanding any arrangement that require such Entities to share the profits of their subsidiaries.

Paragraph (f)

109. Paragraph (f) states that all the Constituent Entities of the Multi-Parented MNE Group are required to apply the UTPR in accordance with Articles 2.4 to 2.6. It further clarifies that the UTPR shall take into account the Top-up Tax computed in respect of any LTCE that is a member of the Multi-Parented MNE Group. This means a single UTPR Top-up Tax Amount is calculated for the whole Multi-Parented MNE Group by aggregating the Top-up Tax of all the members of the Multi-Parented MNE Group, taking into account the other relevant provisions such as Article 9.3. This also means that an Entity that would otherwise be a Constituent Entity of only one of the Groups can be required to apply the UTPR with respect to an amount of Top-up Tax of another Constituent Entity that would otherwise be a Constituent Entity of another Group.

Paragraph (g)

110. Lastly, paragraph (g) clarifies that all of the UPEs are required to submit a GloBE Information Return in accordance with Article 8.1. The Article contains an exception to this rule where they appoint a single Designated Filing Entity, which could be one of the UPEs or another Constituent Entity of the Multi-Parented MNE Group. Furthermore, paragraph (g) states that the GloBE Information Return shall include the information of all Groups that are part of the Multi-Parented MNE Group. The information required under Chapter 8 should be reported as if all of the Groups were a single MNE Group. Paragraph (g) does not otherwise alter the rules in Article 8.1, such as the obligation of all Constituent Entities located in a jurisdiction to submit a GloBE Information Return in case it is not submitted by a Designated Local Entity, or by the UPEs or a Designated Filing Constituent Entity located in a jurisdiction with a Qualifying Competent Authority Agreement.

References

IFRS Foundation (2022), *International Financial Reporting Standards*, <https://www.ifrs.org/>. [2]

Notes

¹ The application of Article 6.2.1(e) is illustrated in the Examples to the Commentary on the Model GloBE Rules under Pillar Two: <https://www.oecd.org/tax/beps/tax-challenges-arising-from-the-digitalisation-of-the-economy-global-anti-base-erosion-model-rules-pillar-two-examples.pdf>.

² Deferred tax assets and liabilities arising in connection with a business combination should be distinguished from the deferred tax assets and liabilities of an acquired Constituent Entity that existed before the Constituent Entity joined the MNE Group.

³ Under IFRS, for example, *joint control is the contractually agreed sharing of control of an arrangement, which exists only when decisions about the relevant activities require the unanimous consent of the parties sharing control* (IFRS 11, paragraph 7), while *significant influence is the power to participate in the financial and operating policy decisions of the investee but is not control or joint control over those policies* (IAS 28, paragraph 3) (IFRS Foundation, 2022^[2]).

7 Tax neutrality and distribution regimes

1. Chapter 7 contains special rules that are applicable to certain tax neutrality and distribution tax regimes. These special rules adapt the GloBE Rules to the unique features of these regimes.

Article 7.1 - Ultimate Parent Entity that is a Flow-through Entity

2. A jurisdiction's tax system may contain rules designed to achieve a single level of taxation on business income. While some jurisdictions may achieve this by adjusting the treatment of income in the hands of the owner (e.g. by exempting distributions received by shareholders), others may provide for a similar result by adjusting the treatment of income in the hands of the business entity (e.g. by treating certain entities or arrangements as transparent for tax purposes or permitting that entity or arrangement to deduct distributions to its investors from its taxable income). These regimes are premised on the idea that the tax on the entity's income is effectively collected at the level of the owner, either by taxing that owner directly on its allocable share of the entity's income (in the case of a Tax Transparent Entity) or by taxing the owners on a Deductible Dividend paid by the entity (in the case of a Deductible Dividend Regime, discussed in the Commentary to Article 7.2).

3. These approaches to single-level taxation could result in unintended outcomes under the GloBE Rules when they apply to the UPE. This is because the ETR of the UPE itself will be nil (or very low), potentially resulting in a significant Top-up Tax charge even though the burden of taxation has not been avoided but rather is borne by the Entity's owners.

4. Such an outcome would indeed result from an application of the relevant rules in Chapters 3 and 4. While the income allocation rules for a Tax Transparent Entity under Article 3.5.1(a) and (b) ordinarily match the income with the Covered Taxes (i.e. both in the hands of the owners or PEs), this does not work where the Tax Transparent Entity is the UPE, because its owners are not Group Entities. Accordingly, Article 3.5.1(c) allocates the income of a Tax Transparent Entity that is the UPE to the Entity itself. Furthermore, Article 4.3, which allocates Covered Taxes paid by one Constituent Entity in connection with income earned by another Constituent Entity does not apply in the case of taxes paid by persons that are not Group Entities. Allocating the taxes accrued by the owners that are outside the MNE Group would be both against the policy intention of the GloBE Rules (which is to ensure that a minimum tax is paid by MNE Groups), and administratively difficult (to obtain the necessary information from, and extract the relevant portion of taxes paid by, unrelated or uncontrolled owners of the UPE).

5. The rules in Article 7.1 resolve this issue for certain situations. The principle underlying the rules in Article 7.1 is that to the extent that the tax neutrality regime imposes tax on the UPE's owners (e.g. partners, beneficiaries or shareholders) at or above the Minimum Rate on the UPE's income contemporaneously or within a short time, the UPE's exposure to Top-up Tax will likewise be reduced. This is achieved by a reduction to the GloBE income of the UPE corresponding to the share of its income that is subject to tax at or above the minimum rate in the hands of its owners (and thereby reducing, perhaps eliminating, any exposure to Top-up Tax).

6. For purposes of applying Article 7.1, the GloBE Implementation Framework will consider providing Agreed Administrative Guidance on the treatment of a Tax Transparent Entity that would be the UPE of the MNE Group if its Controlling Interests were not held by an Excluded Entity.

Article 7.1.1

7. Article 7.1.1 permits the UPE to reduce its GloBE Income for a Fiscal Year in the three situations described in paragraphs (a) to (c).

8. The rules of Article 7.1.1 apply with respect to each Ownership Interest. The UPE will reduce its GloBE Income by the amount of GloBE Income attributable to each Ownership Interest that meets a criterion in paragraphs (a) to (c). The remainder of the income, if any, will be included in the computation of the UPE's GloBE Income or Loss and included in the computation of the Net GloBE Income for the jurisdiction under Article 5.1.2.

Paragraph (a)

9. The general rule is described in paragraph (a).¹ The paragraph sets out two tests that must be met with respect to each Ownership Interest for the reduction to apply: a taxable period test and a minimum tax test. The first test is included at the beginning of paragraph (a) and requires that the holder is subject to current taxation on such income. Specifically, the holder must be subject to tax on its share of the UPE's GloBE Income for a taxable period that ends within 12 months of the end of the MNE Group's Fiscal Year. The holder is not required to pay its tax liability within 12 months of the end of the MNE Group's Fiscal Year to meet this test. It is sufficient that the holder's share of the UPE's GloBE Income is included in its taxable income for a taxable year that ends within 12 months of the MNE Group's Fiscal Year end.

10. A holder is subject to tax on its share of the UPE's GloBE Income if that income is includible in the holder's taxable income under the laws of the jurisdiction in which the holder is tax resident or includible in taxable income of a PE of the holder.

11. The second test evaluates the holder's level of taxation and can be satisfied if the conditions in subparagraphs (i) or (ii) are met. The conditions in subparagraphs (i) to (ii) are alternatives; thus, the conditions in only one of the subparagraphs need to be satisfied.

12. Subparagraph (i) is met if the holder is subject to tax on the full amount of its share of the GloBE Income (that is, for example, without the benefit of an exemption) and subject to tax at a nominal rate that equals or exceeds the Minimum Rate (meaning no ETR calculation is required in respect of the holder). Temporary difference (i.e. a timing difference) between the time an item of income or expense is included in the computation of GloBE Income or Loss and the UPE's taxable income will not cause a holder to fail the requirement that it be subject to tax on the full amount of such income (as well as meeting the 12 month requirement in paragraph (a)). For example, if the UPE is allowed to use an accelerated depreciation method to compute the taxable income allocable to its holders, the difference in the timing of the income will not cause the holders to be considered subject to tax on less than the full amount of the UPE's GloBE Income. A holder is considered subject to tax on the full amount of its GloBE Income even if its taxable income includes expenses or losses related to other investments or businesses or profit-seeking activities. For purposes of subparagraph (i), the nominal rate is the statutory rate applicable to the holder on its share of the UPE's income. If the holder is subject to graduated rates, the nominal rate is the highest rate applicable to the holder determined as if its share of the UPE's GloBE income were its total taxable income.

13. The conditions in subparagraph (i) are met with respect to holders that are not residents of the UPE Jurisdiction if the UPE Jurisdiction subjects them to tax at or above the Minimum Rate either because they are treated as having a PE in the UPE Jurisdiction or because the income is sourced in the UPE's jurisdiction and subject to a withholding or similar source-based tax. In the event that the non-resident holders are not subject to tax in the UPE's jurisdiction at a nominal rate that equals or exceeds the Minimum

Rate, additional information will be required in order for the UPE to demonstrate that those holders are subject to tax on their share of the income within 12 months at a nominal rate that equals or exceeds the Minimum Rate.

14. The alternative conditions under subparagraph (ii) are met if it can be reasonably expected that the aggregate amount of Covered Taxes (paid by the UPE and other Entities that are part of the Tax Transparent Structure) and taxes paid by the holder on the income attributable to the Ownership Interest equals or exceeds the amount that results from multiplying the full amount of such income by the Minimum Rate. Whether the taxes paid can be reasonably expected to equal or exceed the tax at the Minimum Rate is determined based on all the facts and circumstances. The MNE Group bears the burden of proving that the expectations are reasonable.

15. Subparagraph (ii) does not require an ETR computation. Its conditions are met if the UPE demonstrates that it is reasonable to expect that its income will be subject to an amount of tax that equals or exceeds the tax liability on that income at the Minimum Rate. Subparagraph (ii) takes into account the net amount of taxes paid by the UPE and other Entities that are part of the Tax Transparent Structure and by the holder of the UPE's Ownership Interest on its share of the UPE's income. It requires that the taxes paid by the UPE and other Entities that are part of the Tax Transparent Structure are Covered Taxes and that the taxes paid by the holders are taxes on the income of the UPE. For instance, the UPE could be required to pay a local Covered Tax notwithstanding that its income is allocated to its holders under federal law. In this case, subparagraph (ii) is met if it is expected that the net amount of tax paid by the UPE itself and the holder equals or exceeds the minimum tax on that income.

Paragraph (b)

16. Paragraph (b) provides a safe harbour to a Flow-through UPE with owners that are natural persons that hold small Ownership Interests in the UPE. Determining the tax position of minority owners may be burdensome for the UPE. Because natural persons are typically not eligible for preferential tax rates on income derived through a Tax Transparent Entity, it is reasonable not to require the UPE to determine the tax position of a natural person that holds Ownership Interests that in aggregate carry rights to 5% or less of the profits and assets of the UPE. This rule means that a UPE could be required to determine the tax position of no more than 19 natural persons, and such persons would have relatively significant stakes in the UPE. This safe harbour only applies where the two conditions in subparagraphs (i) and (ii) are met.

17. Subparagraph (i) requires the natural person to be a tax resident of the UPE Jurisdiction. A natural person is tax resident in a jurisdiction only if the person is subject to individual income tax in such jurisdiction. Consequently, a natural person cannot be tax resident in a jurisdiction that does not impose an individual income tax. Therefore, there is an expectation that the UPE's income is subject to tax in the hands of the natural person because they are both located in the same jurisdiction and therefore subject to the same tax laws regarding fiscal transparency. It is further reasonable to expect that the jurisdiction is subjecting natural persons to tax at a rate that equals or exceeds the Minimum Rate on their income derived from Flow-through Entities. Therefore, it is assumed that such persons are going to be subject to tax on the full amount of income attributable to their Ownership Interests at a rate that equals or exceeds the Minimum Rate. The UPE may use reasonable means of determining whether its owners are tax resident in the jurisdiction. For example, a UPE in a jurisdiction that imposes a withholding tax on the profits or distributions from the UPE with respect to foreign owners of the UPE may rely on an owner's representation as to whether it is exempt from a withholding tax or eligible for a lower withholding tax rate based on a Tax Treaty.

18. Subparagraph (ii) limits the safe harbour to natural persons that each hold Ownership Interests that in aggregate carry rights to 5% or less of the profits and 5% or less of the assets of the UPE. For example, this means that an Ownership Interest giving rights to 51% of profits would fall outside the safe harbour in 7.1.1(b), despite giving rights to less than 5% of the assets. The extent of each person's

Ownership Interests is determined as of the end of the Fiscal Year. This subparagraph only applies where the Ownership Interests of the UPE are held directly by natural persons.

Paragraph (c)

19. Paragraph (c) is the last scenario in which Article 7.1.1 applies. It covers the case where the holder of the Ownership Interest in the UPE is a Governmental Entity, International Organisation, a Non-profit Organisation, or a Pension Fund. However, similar to paragraph (b), paragraph (c) only applies where two conditions are met.

20. The first condition is set out in subparagraph (i). It requires the Governmental Entity, International Organisation, Non-profit Organisation or Pension Fund to be resident in the UPE Jurisdiction. The term “resident” in paragraph (c) is not the same as “tax residence” as used in Tax Treaties, Article 10.2 or Article 10.3. For purposes of Article 7.1.1, these Entities are resident in the jurisdiction where they are created and managed. A Governmental Entity is resident only in the jurisdiction of the government (including any political subdivision or local authority thereof) of which it is a part or that wholly owns it. Whether an Entity is resident in a jurisdiction is determined based on all facts and circumstances.

21. The second condition, included in subparagraph (ii), requires that each Entity holds Ownership Interests that in aggregate carry rights to 5% or less of the profits and assets of the UPE. This is the same condition as in paragraph (b)(ii). These Ownership interests must also be directly held by the Governmental Entity, International Organisation, Non-profit Organisation or Pension Fund for the condition to be satisfied. The definitions of these Entities generally prohibit the Entity from carrying on a trade or business. This ownership limitation is designed to ensure that Article 7.1 cannot be used to circumvent the prohibition from carrying on a trade or business by carrying on a trade or business through a Tax Transparent Entity.

22. Ownership Interests in the Tax Transparent Entity held by Investment Entities are not included in paragraph (c) because Investment Entities are tax neutral whereas the Entities described in paragraph (c) are generally not subject to tax under the laws of the UPE’s jurisdiction. An Investment Entity itself may be subject to tax at a rate below the Minimum Rate and the UPE would have no knowledge of the taxability or residency of the Investment Entity’s owners. Thus it is not appropriate to extend the rule in paragraph (c) to Investment Entities.

Article 7.1.2

23. Article 7.1.2 provides a corollary to Article 7.1.1 for losses. Losses incurred by a Flow-through Entity typically flow through to the holders and are allowed as a deduction in computing the holder’s taxable income or loss, and may even contribute to a loss carry-back or carry-forward that reduces the holder’s share of prior or future income from the Flow-through Entity or other income. In some jurisdictions, however, losses of a Flow-through Entity are retained by the Entity and carried forward in the determination of the Entity’s future taxable income.

24. Article 7.1.2 provides that the GloBE Losses incurred by a UPE that is a Flow-through Entity must also be reduced by the amount attributable to each Ownership Interest, except to the extent that the holders of Ownership Interests are not allowed to use the loss in computing their separate taxable income. This means that the GloBE Loss is not reduced to zero only if the loss does not flow through, in its entirety, to the holders of Ownership Interests under the tax laws applicable to the Entity and to the holders so as to allow the holders to use their share of such loss in computing their separate taxable income. To the extent that the GloBE Loss is not reduced to zero, the remaining GloBE Loss stays with the Flow-through UPE. Without this rule, losses that are passed through to the holders of Ownership Interests would also be available for use in the jurisdictional ETR calculation to shield GloBE income of other Constituent Entities located in the UPE’s Jurisdiction.

25. To the extent that a GloBE loss of a Flow-through UPE is not reduced to zero pursuant to Article 7.1.2 (and thus stays with the Flow-through UPE), a Filing Constituent Entity may make a GloBE Loss Election that is limited to the UPE under Article 4.5.6, and carry forward the balance as a GloBE Loss Deferred Tax Asset to subsequent Fiscal Years. The GloBE Loss Deferred Tax Asset is computed based on the amount of the GloBE Loss remaining after application of Article 7.1.2 and may be included in the UPE's Adjusted Covered Taxes in a subsequent year for purposes of applying Article 7.1.1(a)(ii).

26. Article 7.1.2 applies with respect to each Ownership Interest similar to Article 7.1.1. Therefore, the MNE Group is required to demonstrate that each of its holders is not able to deduct losses attributed to their Ownership Interest in the computation of their separate taxable income in order to include their share of the loss in the GloBE Loss Deferred Tax Asset computed under Article 4.5.6.

Article 7.1.3

27. Article 7.1.3 requires the UPE to reduce its Covered Taxes, if any, in proportion to the income reduction under Article 7.1.1. Thus, if the UPE reduces its GloBE Income by 80% pursuant to Article 7.1.1, the UPE must also reduce its Covered Taxes by 80%. In many cases, by virtue of the tax transparency regime, the UPE may not have any Covered Taxes. However, it is possible that Covered Taxes other than the national CIT are imposed on Flow-through Entities, such as those imposed by a local, sub-national government. Although the Covered Taxes excluded by Article 7.1.3 are not taken into account in the ETR computation for the UPE Jurisdiction, they are taken into account under Article 7.1.1(a)(ii) in determining whether the taxes on the holder's share of the UPE's GloBE Income equal or exceed the tax at the Minimum Rate on that income.

28. Article 7.1.1 reduces the Flow-through Entity's GloBE Income by all of the GloBE Income (determined after adding back Covered Taxes) allocable to an Ownership Interest. Accordingly, no further adjustment is required to reduce the Entity's GloBE Income by the related Covered Taxes as required under Article 7.2.2.

Article 7.1.4

29. Article 7.1.4 extends the treatment of Article 7.1.1 to 7.1.3 to certain PEs through which the UPE and certain other Flow-through Entities of the MNE Group conduct their business. Paragraph (a) covers the case where the business of the flow-through UPE is wholly or partly carried out through a PE.

30. Paragraph (b) covers the situations where the flow-through UPE directly holds the Ownership Interests of another Tax Transparent Entity whose business is wholly or partly carried out through a PE. This is the case where the Financial Accounting Net Income or Loss attributable to the PE is included in the financial statements of the Flow-through Entity held by the UPE.

31. Paragraph (b) is also extended to the scenario where the Flow-through UPE holds the Ownership Interest of the Tax Transparent Entity and the PE through a Tax Transparent Structure (see Article 10.2). This allows Article 7.1.4 also to apply to PEs held by the UPE through a chain of Tax Transparent Entities.

32. In all of these cases, the Financial Accounting Net Income or Loss attributable to the PE is included in the financial statements of the UPE, but liability for the tax on that income may be borne by the UPE or by the holders of the UPE. Where the tax on the income of the PE is borne by the holders, the PE's GloBE Income is reduced to the extent the conditions of Article 7.1.1(a) or (b) are met. In such cases, Article 7.1.1(b) takes into account any tax paid or payable in the jurisdiction where the PE is located regardless of whether that tax is paid or payable by a Constituent Entity or by the holders of the UPE.

33. Furthermore, the test in Article 7.1.1 applicable to the GloBE Income of the PE is separate from the test applicable to the GloBE Income that has been allocated to the UPE. This means that the GloBE Income or Loss of the PE is not included in the GloBE Income of the UPE for purposes of applying 7.1.1

to the UPE. The PE is treated separately from the UPE under Article 7.1.4 because it is a separate Constituent Entity and its income does not flow-through to the UPE under Chapter 3 as does the income of a Tax Transparent Entity. However, to the extent that the conditions of Article 7.1.1 are met by a holder of an Ownership Interest in the UPE with respect to the income of the PE, the PE's GloBE Income is reduced pursuant to Article 7.1.4.²

Article 7.2 - Ultimate Parent Entity subject to Deductible Dividend Regime

34. Article 7.2 contains a set of rules for UPEs that are subject to a Deductible Dividend Regime. These rules allow a deduction in the computation of the GloBE Income or Loss for Deductible Dividends. Deductible Dividend Regimes typically apply to investment companies as well as Cooperatives. Although a Deductible Dividend Regime may apply to both Entities that qualify as Investment Entities under the GloBE Rules and other similar purpose Entities that do not meet the Investment Entity definition, the rules in Article 7.2 are needed only for those Entities that do not meet the Investment Entity definition because an Investment Entity that is the UPE is an Excluded Entity.

35. A Deductible Dividend Regime is a tax regime designed to yield a single level of taxation on the owners of an Entity through the allowance of a deduction from the income of the Entity for distributions of profits to the owners. The owners are subject to tax on the dividends and the Entity is subject to tax on earnings that are not distributed. Patronage dividends of a Cooperative are treated as distributions to owners under the definition of Deductible Dividend Regime in Article 10.1, and thus tax regimes intended to yield a single level of taxation for Cooperatives and their patrons will typically qualify as Deductible Dividend Regimes.

36. Deductible Dividends are defined in Article 10.1 as distributions of profits that are deductible from taxable income under the laws of the jurisdiction in which the Constituent Entity is located and patronage dividends paid by a Cooperative. Because the definition of Deductible Dividend Regime includes Cooperatives that are subject to an exemption regime, application of Article 7.2 to Cooperatives is not dependent upon allowance of a deduction from taxable income at the Cooperative level; Article 7.2 equally applies in the case of a Cooperative that is tax exempt under the laws of the jurisdiction in which it is located.

37. The substantive rules applicable to UPEs that are subject to Deductible Dividend Regimes are similar to the rules for UPEs that are Tax Transparent Entities. An important difference, however, is the treatment of losses incurred by the Constituent Entity. Unlike the treatment of losses incurred by a Tax Transparent Entity under local tax rules, the losses of an Entity subject to a Deductible Dividend Regime do not flow through to the owners. Accordingly, the GloBE Rules applicable to Deductible Dividend Regimes do not contain special rules for a GloBE Loss determined for a Constituent Entity. Such losses are taken into account in the computation of the Net GloBE Income for the jurisdiction in which the Entity is located.

Article 7.2.1

38. Similar to Article 7.1.1, Article 7.2.1 allows for a reduction of the UPE's GloBE Income (but not below to zero) by the amount of Deductible Dividends if the UPE is subject to a Deductible Distribution Regime. The provision applies if the Deductible Dividends are distributed within 12 months of the end of the UPE's Fiscal Year. The Constituent Entity must maintain records sufficient to demonstrate the amount of GloBE Income for a Fiscal Year that was distributed within 12 months of the end of the Fiscal Year. Furthermore, it only applies in the cases described in paragraphs (a) to (c).

Paragraph (a)

39. Paragraph (a) requires that the Deductible Dividends are subject to tax in the hands of the recipient within 12 months of the end of the UPE's Fiscal Year. It further requires that one of the conditions set out in subparagraphs (i) to (iii) is met.

40. Subparagraph (i) sets out the general test for determining whether the Deductible Dividends reduce the UPE's GloBE Income for the Fiscal Year. Under the primary test, the UPE's GloBE Income is reduced by Deductible Dividends to recipients that are subject to a nominal tax rate that equals or exceeds the Minimum Rate.

41. Subparagraph (ii) sets out an alternative, independent test. The conditions under paragraph (ii) are met if it can be reasonably expected that the aggregate amount of Covered Taxes (paid by the UPE) and taxes paid by the owner on the income attributable to its Ownership Interest equals or exceeds the amount that results from multiplying the full amount of such income by the Minimum Rate. Subparagraph (ii) does not require an ETR computation. The conditions under this paragraph are met if the UPE demonstrates that it is reasonable to expect that tax paid in respect of its income will equal or exceed the tax liability on that income at the minimum rate.

42. Subparagraph (iii) contains a special rule for patronage dividends distributed to natural persons that are members of supply Cooperatives. A supply Cooperative is a Cooperative that purchases goods or services and resells them to its members or patrons. Profits earned by the supply Cooperative are distributed to the members, typically in proportion to their purchases from the Cooperative. Most supply Cooperatives are organised for the acquisition of goods for a group of merchants. However, some supply Cooperatives are organised for the benefit of consumers that are natural persons. Unless they are engaged in business as a sole proprietor, natural persons generally are not able to deduct the cost of the goods acquired through a supply Cooperative. To ensure that the GloBE Rules accommodate supply Cooperatives with members that are consumers, patronage dividends paid to natural persons from a supply Cooperative are treated in the same manner as distributions that are subject to tax at or above the Minimum Rate. This special rule means that such dividends are treated as subject to tax when received irrespective of whether they are in fact taxable receipts of the recipient.

Paragraph (b)

43. Paragraph (b) covers the case where the dividend recipient is a natural person that is tax resident in the UPE Jurisdiction and that holds Ownership Interests that in aggregate carry rights to 5% or less of the profits and assets of the UPE. The Commentary to Article 7.1.1(b) is applicable to Article 7.1.2 (b) as both provisions use the same language and are intended to have the same scope.

Paragraph (c)

44. Paragraph (c) covers the case where the dividend recipient is a Governmental Entity, an International Organisation, a Non-profit Organisation or a Pension Fund that is not a Pension Services Entity. Paragraph (c) only applies where these Entities are "resident" in the UPE jurisdiction. The term "resident" in paragraph (c) is not the same as "tax residence" as used in Tax Treaties or Article 10.2. For purposes of Article 7.2.1, these Entities are resident in the jurisdiction where they are created and managed. A Governmental Entity is resident only in the jurisdiction of the government (including any political subdivision or local authority thereof) that it is a part of or that wholly-owns it. Whether an Entity is resident in a jurisdiction is determined based on all facts and circumstances.

45. Paragraph (c) of Article 7.2.1 differs from paragraph (c) of Article 7.1.1 in that it only applies in the case of a Pension Fund that is not a Pension Services Entity. Thus, Article 7.2.1(c) only applies in relation to a dividend paid to the parent Pension Fund by a UPE in the Pension Fund's jurisdiction. Without this limitation, Article 7.2.1(c) could allow Pension Funds to take advantage of Deductible Dividend Regimes

to earn income exempt from the GloBE Rules from UPEs located anywhere in the world by simply establishing a Pension Services Entity in the UPE's jurisdiction. The paragraph also differs from Article 7.1.1(c) by not imposing a limitation on the amount that can be owned by the Entities. As explained in the Commentary to Article 7.1.1(c), that limitation prevents circumvention of the rules that generally prevent these Entities from carrying on a trade or business. Deductible Dividend Regimes typically apply to Entities that engage in investment activities or to Cooperatives, and are more difficult to use, and thus less likely to be used, as a means of circumventing the prohibition on carrying on a trade or business.

Article 7.2.2

46. Article 7.2.2 is similar to Article 7.1.3. It generally requires a reduction of the UPE's Covered Taxes in proportion to the income distributed as a Deductible Dividend. However, this reduction does not apply to any taxes paid on undistributed GloBE Income pursuant to the Deductible Dividend Regime itself (including taxes that are based on corporate equity or retained earnings). All of the tax paid under the Deductible Dividend Regime (including taxes that are based on corporate equity or retained earnings) in respect of undistributed income is included in the Entity's Covered Taxes and taken into account along with the undistributed income in determining the ETR for the jurisdiction.

47. Article 7.2.2 also requires a reduction of the UPE's GloBE Income by the amount of the reduction in the Covered Taxes. This is necessary because of two features of the GloBE Rules concerning Deductible Dividend Regimes. First, GloBE Income is computed under Article 3.2 by adding back Covered Taxes to the Financial Accounting Net Income or Loss. Second, Article 7.2.1 reduces the UPE's income by the amount of distributions, which are necessarily comprised of after-tax income. Thus, if the UPE incurs any taxes related to distributed income, the amount of the distribution will not reduce the UPE's GloBE Income to zero; the GloBE income must also be reduced by the tax that was included in the GloBE Income under Article 3.2. Without this rule, Top-up Tax could arise even where all of the UPE's earnings were distributed as Deductible Dividends.

48. For example, assume that a UPE has 90 of Financial Accounting Net Income, which includes 10 of accrued Covered Tax expense. The UPE distributes the 90 of income for which it receives a deduction under the applicable Deductible Dividend Regime. The UPE's GloBE Income, however, is 100 because the 10 of Covered Taxes is added back to Financial Accounting Net Income or Loss pursuant to Article 3.2.1(a). Accordingly, the 90 distribution will not reduce its 100 GloBE Income to zero. Article 7.2.2 requires a further reduction of 10 to the UPE's GloBE Income to ensure that the MNE Group is not subject to Top-up Tax in respect of the Covered Taxes added back to the determination of GloBE Income or Loss.

Article 7.2.3

49. Article 7.2.3 is similar to Article 7.1.4. It extends the rules applicable to the UPE to other Constituent Entities located in the UPE Jurisdiction that are subject to the Deductible Dividend Regime and held through an ownership chain made up exclusively of such Entities. However, the income of the Constituent Entities that are not the UPE is reduced only to the extent it is distributed to the UPE and then by the UPE to recipients that meet the requirements of Article 7.2.1. The Ultimate Parent Entity must maintain records sufficient to demonstrate that such distributions occurred within 12 months of the end of the Fiscal Year of the subsidiary Entity subject to the Deductible Dividend Regime. The UPE may use any reasonable method of determining the source of any intra-group distributions from other Entities, including determining the income of Entities that are subject to a Deductible Dividend Regime and Entities that are subject to an ordinary income tax, that have not been distributed to the UPE's owners.

Article 7.2.4

50. Article 7.2.4 provides rules to clarify the application of Article 7.2.1 with respect to certain patronage dividends distributed by supply Cooperatives. The rule applies to dividend recipients other than natural persons because distributions from supply Cooperatives to natural persons are always treated as a reduction to the UPE's GloBE Income under Article 7.2.1(a)(iii).

51. Patronage dividends from a supply Cooperative may not be subject to tax in the same way that patronage dividends from a marketing cooperative are subject to tax. A marketing Cooperative is one in which members sell their products or services to the Cooperative and the Cooperative re-sells those products or services to its customers. Patronage dividends received by a business from a marketing cooperative essentially represent additional sales price for the goods or services provided by the cooperative member. Patronage dividends received by a business from a supply cooperative, on the other hand, essentially represent a reduction in the cost of goods or services acquired through the cooperative. Because of the difference in the character, from an accounting, and perhaps tax perspective, Article 7.2.4 treats patronage dividends from a supply Cooperative as "subject to tax" in the hands of the recipient to the extent they reduce an expense or cost that is deductible in the computation of the dividend recipient's taxable income. Whether the dividend is then subject to tax at a rate above the Minimum Rate is determined based on the relevant rules in Article 7.2.1.

Article 7.3 - Eligible Distribution Tax Systems

52. Article 7.3 allows certain distribution tax regimes to be accommodated within the structure of the GloBE Rules, subject to certain safeguards and recapture rules. A distribution tax regime is a tax system that generally imposes income tax on a corporation when the corporation's income is distributed or deemed to be distributed to its shareholders, rather than when it is earned. Distribution tax regimes also impose current tax in respect of certain non-business expenses. Current taxation based on these disallowed expenditures is equivalent to disallowing a deduction for such expenses under a more traditional income tax. Because these non-business expenditures reduce distributable earnings, they cannot be subject to tax on distribution as a practical matter.

53. The tax rates applicable under a distribution tax regime may equal or exceed the Minimum Rate such that the income is not subject to a low rate of tax when the earnings are eventually distributed. Absent a distribution or deemed distribution, however, much of the income is not subject to tax in the year it is earned and reported in the financial accounts. Moreover, the rules in Article 4.3 generally do not permit deferred tax liabilities in respect of taxes payable upon distribution to be included in the computation of the Total Deferred Tax Adjustment Amount. This means that the Constituent Entity's GloBE Income likely would be subject to tax under the GloBE Rules in those years in which there is not an actual or deemed distribution because the Adjusted Covered Taxes for the Fiscal Year will be very small or nil. Moreover, in years where distributions are made, the amount of the distributions may bear no relationship to the income arising in those years, which may result in low or even extremely high ETRs. Article 7.3 mitigates these differences between the time the income accrues in the financial accounts and the time it is subject to distribution tax to the extent that distributions are made within a four-year period.

Article 7.3.1

54. Article 7.3.1 allows the Filing Constituent Entity to make an annual election in respect of a Constituent Entity that is subject to a Eligible Distribution Tax System to add the Deemed Distribution Tax to the Adjusted Covered Taxes for the Fiscal Year. An election under Article 7.3.1 is subject to the other provisions of Article 7.3.

Article 7.3.2

55. Article 7.3.2 determines the amount of Deemed Distribution Tax. It is the lesser of (a) the amount necessary to increase the Effective Tax Rate computed under Article 5.2.1 for the jurisdiction for the Fiscal Year to the Minimum Rate or (b) the amount of distribution tax that would have been paid if the Constituent Entities in the jurisdiction had distributed all of their income that is subject to the Eligible Distribution Tax Regime during such Fiscal Year. Thus, if the GloBE Income for the Fiscal Year were to exceed the amount of earnings that could be distributed and subject to tax upon distribution for that Fiscal Year, the Deemed Distribution Tax would be limited under paragraph (b) to the amount of tax that would arise if all taxable earnings for the Fiscal Year were distributed.

56. The purpose of the limitation in paragraph (b) is to ensure that under ordinary circumstances the Deemed Distribution Tax does not exceed the amount of tax that could possibly arise under the relevant distribution tax system for a Fiscal Year if all earnings were distributed in the year earned. The rule is not intended to supplant or interfere with the rules in Articles 7.3.3 and 7.3.4 for establishing and using a Recapture Account Loss Carry-forward. Thus, the computation under paragraph (b) is made without regard to any negative balance in the accumulated earnings of Constituent Entities in the jurisdiction as of the end of the preceding Fiscal Year.

Article 7.3.3

57. In order to track the extent to which Deemed Distribution Tax is paid within the 4-year period, a Deemed Distribution Tax Recapture Account for each Fiscal Year in which the election was made must be maintained and available for examination by the tax authorities of jurisdictions imposing the GloBE Rules. The Deemed Distribution Tax Recapture Accounts are maintained on a jurisdictional basis. This facilitates jurisdictional blending of income. It also ensures that the adjustments to the recapture accounts accommodate a consolidation or group relief system in the jurisdiction and allows distributions from any Constituent Entity to eliminate the account.

58. A Deemed Distribution Tax Recapture Account is established for each Fiscal Year in an amount equal to the Deemed Distribution Tax. These annual accounts can be reduced in the three ways described in more detail below. The accounts are reduced in chronological order beginning with the account established for the earliest Fiscal Year and cannot be reduced below zero.

59. Deemed Distribution Tax Recapture Accounts are first reduced by distribution taxes actually paid by the Constituent Entities as a result of distributions or deemed distributions. Distribution taxes are charged against the Deemed Distribution Tax Recapture Accounts in chronological order. The accounts are maintained based on the amount of Deemed Distribution Tax rather than the amount of GloBE Income arising in the relevant Fiscal Year. Consequently, if the jurisdiction decreases the distribution tax rate, more income will need to be distributed to yield the amount of tax necessary to eliminate the potential recapture. On the other hand, if the jurisdiction were to increase the distribution tax rate, the Constituent Entities could eliminate the accounts by distributing less of their income.

60. Second, the accounts are reduced when the jurisdiction has an overall GloBE Loss, meaning the aggregate GloBE Loss of Constituent Entities exceeds the aggregate GloBE Income of Constituent Entities located in the jurisdiction. The reduction for GloBE Losses is applied to the oldest Deemed Distribution Tax Recapture Account to the extent thereof and then to newer accounts to the extent necessary to absorb the entire loss. Because the accounts are maintained in terms of Deemed Distribution Taxes rather than income, the amount of any GloBE Loss for the jurisdiction has to be translated into an equivalent negative distribution tax amount. This translation must be based on the Minimum Rate. Thus, the GloBE Loss for the Fiscal Year is multiplied by the Minimum Rate and the result is applied against Deemed Distribution Tax Recapture Accounts in chronological order. This rule effectively permits a carry-back of losses in a

Distribution Tax System. Carry-back is necessary because these losses will eliminate distributable profits and thus the Constituent Entity's ability to distribute dividends that are subject to the distribution tax.

61. Finally, the Deemed Distribution Tax Recapture Accounts are reduced by the amount of a Recapture Account Loss Carry-forward determined under, and applied to the Fiscal year, pursuant to Article 7.3.4.

Article 7.3.4

62. When there is a Net GloBE Loss for the jurisdiction that exceeds the amount in all of the Deemed Distribution Tax Recapture Accounts, a Recapture Account Loss Carry-forward is created. This account is reduced in subsequent years as the loss carry-forward is applied to reduce the GloBE Income that would otherwise be subject to the Deemed Distribution Tax. The account ensures that the MNE Group is not taxed under the GloBE Rules in excess of its economic income earned through Entities subject to a Distribution Tax Regime.³

63. When a Constituent Entity located in the jurisdiction leaves the MNE Group or when substantially all of the assets of a Constituent Entity are transferred outside the MNE Group or outside the jurisdiction, the Recapture Account Loss Carry-forward must be reduced to the extent it is attributable to such Constituent Entity. The amount attributable to a Constituent Entity is determined by multiplying the Recapture Account Loss Carry-forward by the ratio of the GloBE Loss of that Constituent Entity in the Fiscal Year(s) that produced a Net GloBE Loss in excess of the Deemed Distribution Tax Recapture Accounts to the total of the GloBE Losses of all Constituent Entities in the jurisdiction for that Fiscal Year(s).

64. The Recapture Account Loss Carry-forward may be carried forward indefinitely. However, the Filing Constituent Entity bears the burden of proof in respect of any Recapture Account Loss Carry-forward used in the computation of the Net GloBE Income of the jurisdiction for a Fiscal Year.

Article 7.3.5

65. Article 7.3.5 mandates that an election under Article 7.3.1 applies to all Constituent Entities located in the jurisdiction.

66. Article 7.3.5 requires the MNE Group to re-calculate the ETR and the amount of Top-up Tax under Article 5.4.1 for the Election Year if the Deemed Distribution Tax Recapture Account established for the year is not reduced to zero before the end of the fourth Fiscal Year after the Fiscal Year for which it was established. The re-calculations under Article 5.4.1 are done by reducing the Adjusted Covered Taxes for the Election Year by the outstanding balance (at the end of the relevant period) of the Deemed Distribution Tax Recapture Account for that year. The Substance-based Income Exclusion used to compute Excess Profits in the Article 5.4.1 re-calculations for the Election Year is computed based on the Eligible Payroll Costs of Eligible Employees arising in the Election Year and the carrying values of Eligible Tangible Assets at the beginning and end of the Election Year. Similarly, if the Election Year is a Fiscal Year covered by the Transition Rules in Article 9.2, the relevant Article 5.3.3 rate and Article 5.3.4 rate apply in the determination of the Substance-based Income Exclusion.

67. The result of Article 7.3.5 should be that the Top-up Tax liability in respect of the Election Year is the same as the Top-up Tax liability that would have been determined for the year if the distribution taxes paid in the following four Fiscal Years had been paid in the Election Year.

Article 7.3.6

68. Article 7.3.6 ensures that payments of distribution taxes, whether as a result of actual or deemed distributions, are not counted once as a reduction to a Deemed Distribution Tax Recapture Account and a second time as Adjusted Covered Taxes. Only distribution taxes paid after all Deemed Distribution Tax

Recapture Accounts have been reduced to zero are treated as Covered Taxes for the Fiscal Year. Taxes paid under an Eligible Distribution Tax Regime in respect of non-business expenses, however, are Covered Taxes and taken into account as such under the rules of Chapter 4.

Article 7.3.7

69. When a Constituent Entity located in the jurisdiction leaves the MNE Group or when substantially all of the assets of a Constituent Entity are transferred outside the MNE Group or outside the jurisdiction, the ETR and Top-up Tax for the jurisdiction must be re-calculated under Article 5.4.1 by reducing the Covered Taxes by the balance of the Deemed Distribution Tax Recapture Account at the end of that Fiscal Year. If the re-calculation under Article 5.4.1 results in Top-up Tax, that amount is multiplied by the Disposition Recapture Ratio and the result is included in the Additional Top-up Tax for the Fiscal Year. This rule recaptures the Deemed Distribution Tax when the Constituent Entity ceases to be in a position to distribute assets that would yield distribution tax to eliminate the balance in the recapture accounts. Article 7.3.7 does not impose tax on gains attributable to a transfer of assets. Accordingly, the rule is not dependent upon whether the transaction is eligible for treatment as a GloBE Reorganisation under Article 6.3.

70. Under Article 7.3.7, the MNE Group applies Article 5.4.1 to all of its Deemed Distribution Tax Recapture Accounts in the Fiscal Year that the Departing Constituent Entity leaves the MNE Group or disposes of substantially all of its assets. The re-calculations under Article 7.3.7 are done in the same manner as under Article 7.3.5. The incremental Top-up Tax computed for each Deemed Distribution Tax Recapture Account is then multiplied by the Disposition Recapture Ratio determined under Article 7.3.8 to determine the amount of Additional Top-up Tax to include for the Fiscal Year under Article 5.2.3. If the Departing Constituent Entity had a GloBE Loss for a Fiscal Year, the Disposition Recapture Ratio for that year will be zero and there will be no recapture amount for that Fiscal Year.

71. After application of Article 7.3.7, the Deemed Distribution Tax Recapture Account, the Net GloBE Income of the jurisdiction, the Adjusted Covered Taxes for the jurisdiction, and the Substance-based Income Exclusion for each Fiscal Year for which there was a Deemed Distribution Tax Recapture Account must be reduced in proportion to the Disposition Recapture Ratio. This can be done by multiplying the amount of each item by the Disposition Recapture Ratio and reducing it by the result or by multiplying the item by the difference between 1.0 and the Disposition Recapture Ratio expressed as a decimal). This will ensure that subsequent adjustments to the Deemed Distribution Tax Recapture Accounts pursuant to Article 7.3.3 are given full effect in the computation of the ETR and Top-up Tax at the end of the four-year period under Article 7.3.5.

Article 7.3.8

72. The Disposition Recapture Ratio is set out in Article 7.3.8. In conjunction with Article 7.3.7, it recaptures the outstanding balance of the Deemed Distribution Tax Recapture Accounts based on the ratio of the sum of the GloBE Income of the Departing Constituent Entity in the Fiscal Years for which a Deemed Distribution Tax Recapture Account is outstanding to the sum of the Net GloBE income of the jurisdiction for those Fiscal Years. Thus, if there are two annual recapture accounts outstanding, the Constituent Entity's GloBE Income or Loss for those two years is compared to the total Net GloBE Income for those two years and the resulting ratio is multiplied by the incremental Top-up Tax computed for each Deemed Distribution Tax Recapture Account under Article 5.4.1 to determine the amount of Additional Top-up Tax to include for the Fiscal Year under Article 5.2.3. If the Departing Constituent Entity had a GloBE Loss in a Fiscal Year for which a Deemed Distribution Tax Recapture Account was established, that GloBE Loss and the account for that Fiscal Year is ignored in the computation of the Disposition Recapture Ratio because the account for that Fiscal Year was not attributable to GloBE income of the Departing Constituent Entity.

Article 7.4 - Effective Tax Rate Computation for Investment Entities

Overview of special rules applicable to Investment Entities in Articles 7.4 to 7.6

73. Investment Entities that are the UPE are excluded from the operation of the GloBE Rules because they are not Constituent Entities of any MNE Group. See Article 1.5.1(e). However, the income of a controlled Investment Entity is consolidated with the MNE Group and brought within the GloBE Rules. Articles 7.4 and 7.5 provide special rules applicable to controlled Investment Entities and Insurance Investment Entities and Article 7.6 provides a special rule applicable to controlled Investment Entities.

74. The rules in Article 7.4 provide a mechanism for calculating the ETR of a controlled Investment Entity or Insurance Investment Entity that is not subject to an election under Articles 7.5 or 7.6 (as applicable). The income of Investment Entities and Insurance Investment Entities is often subject to little or no tax at the entity level. Article 7.4 calculates the ETR and Top-up Tax of these Entities on a standalone basis to prevent an MNE Group from blending this low-taxed income with income of other Constituent Entities. Article 7.4 also seeks to ensure that minority investors are not subject to Top-up Tax on their interest in a low-taxed Investment Entity controlled by an MNE Group. It does so by calculating the ETR and Top-up Tax of a controlled Investment Entity only to the extent that the income is attributable to the MNE Group.

75. Article 7.5 provides an election to treat an Investment Entity or an Insurance Investment Entity as a Tax Transparent Entity. (Investment Entities and Insurance Investment Entities that meet the definition of a Tax Transparent Entity in Article 10.2.1 do not need to make the election.) Under the election, the income and Covered Taxes of the Investment Entity or Insurance Investment Entity flow through to the Constituent Entity-owner and thus the special rules in Article 7.4 are not needed to compute the Investment Entity's ETR. As explained in more detail below, an Insurance Investment Entity is an Entity that would meet the definition of an Investment Entity except that it is wholly-owned by an insurance company. Insurance Investment Entities are eligible to make the Article 7.5 election.

76. Finally, Article 7.6 provides an election for the Constituent Entity-owner of a controlled Investment Entity. Under the election, the Constituent Entity-owner includes distributions received from the Entity in the computation of its GloBE Income or Loss. The Constituent Entity-owner's share of the Investment Entity's income is excluded from the MNE Group's GloBE Income or Loss computations so long as it is distributed to the Constituent Entity-owner within four years.

77. As part of the GloBE Implementation Framework, further consideration will be given to the treatment of Insurance Investment Entities whose Constituent Entity-owners are not subject to a mark-to-market or similar tax regime on their investments in such Entities.

Article 7.4.1

78. Article 7.4 only applies to Investment Entities and Insurance Investment Entities that are not Tax Transparent Entities. The rules contained in Article 3.5 continue to apply to the income of Investment Entities and Insurance Investment Entities that are Tax Transparent Entities. In addition, Article 7.4 does not apply to the portion of an Investment Entity's or an Insurance Investment Entity's income that is subject to an election under Article 7.5 or Article 7.6.

79. Where an Investment Entity or Insurance Investment Entity is a Tax Transparent Entity in part and a Reverse Hybrid Entity in part, Article 7.4.1. applies with respect to its income, expenditure, profit or loss to the extent that it is not fiscally transparent in the jurisdiction in which the owner is located. For example, if an Investment Entity is organised as a trust and taxable on its income that is not distributed to beneficiaries, Article 7.4.1 applies to the extent the Investment Entity's or Insurance Investment Entity's income is not distributed.

Article 7.4.2

80. Article 7.4.2 describes the rules for computing the ETR of an Investment Entity or Insurance Investment Entity. The ETR is calculated separately from any other Constituent Entities in the same jurisdiction (in other words, the GloBE Income or Loss and Covered Taxes are not blended with those of other Constituent Entities in the jurisdiction). However, if the MNE Group owns interests in multiple Investment Entities or Insurance Investment Entities located in the same jurisdiction, a single ETR is computed for all such Entities in the jurisdiction.

81. The ETR is the Investment Entity's or Insurance Investment Entity's Adjusted Covered Taxes (defined in Article 7.4.3) divided by the MNE Group's Allocable Share of the Investment Entity's or Insurance Investment Entity's GloBE Income determined under Chapter 3.

Article 7.4.3

82. Article 7.4.3 provides the calculation of an Investment Entity's or Insurance Investment Entity's Adjusted Covered Taxes. It is the sum of Covered Taxes accrued by the Investment Entity pursuant to Article 4.1 and the Covered Taxes accrued by its Constituent Entity-owners allocable to the Investment Entity or Insurance Investment Entity pursuant to Article 4.3. The Covered Taxes paid by the Investment Entity are only those that correspond to the MNE Group's Allocable Share of the Investment Entity's GloBE Income. The Covered Taxes accrued by Constituent Entity-owners taken into account under Article 7.4.3 are only those that arise with respect to their share of the Investment Entity's or Insurance Investment Entity's income.

Article 7.4.4

83. Article 7.4.4 defines the MNE Group's Allocable Share of the Investment Entity's or Insurance Investment Entity's GloBE Income. It must be calculated in the same way as would have been determined by the UPE in accordance with the rules of Article 2.2.2 taking into account only Ownership Interests in the Investment Entity or Insurance Investment Entity that are not subject to an election under Article 7.5 or Article 7.6. By excluding interests subject to an election under Articles 7.5 and 7.6, the ETR computation for the Investment Entity does not double count taxes that will be taken into account under those elections.

Article 7.4.5

84. Article 7.4.5 provides the rules for computing the Top-up Tax for each Investment Entity or Insurance Investment Entity. These rules are designed to ensure that Top-up Tax arises only with respect to the MNE Group's interest in the Investment Entity or Insurance Investment Entity and taking into account all Covered Taxes arising in respect of that interest.

85. The rules of Article 7.4.5 generally follow the jurisdictional Top-up Tax computational rules in Article 5.2. First, the Top-up Tax Percentage for the Investment Entity or Insurance Investment Entity is computed by subtracting the ETR computed under Article 7.4.2 from the Minimum Rate. Then, the Investment Entity's or Insurance Investment Entity's Substance-based Income Exclusion (computed pursuant to Article 7.4.6) is deducted from the MNE Group's Allocable Share of the Investment Entity's or Insurance Investment Entity's GloBE income under Article 7.4.4. The excess of the MNE Group's Allocable Share of the Investment Entity's or Insurance Investment Entity's GloBE income over its Substance-based Income Exclusion is then multiplied by the Top-up Tax Percentage to determine the Top-up Tax. If there is more than one Investment Entity or Insurance Investment Entity located in the jurisdiction, their attributes determined under Articles 7.4.2 to 7.4.4 are combined to determine the Top-up Tax for all such Entities.

86. In applying Article 2.2, Parent Entities must adjust the computation of their Inclusion Ratio of an Investment Entity that is a LTCE to account for the fact that the Top-up Tax computed for the Entity under

Article 7.4.5 has, in effect, already been reduced by the amount that would have been attributable to other owners that are not Group Entities. For example, assume a Constituent Entity owns 90% of the Ownership Interests that carry rights to 90% of the profits of an Investment Entity and the remaining Ownership Interests are held by persons that are not Group Entities. The Investment Entity earns 100 of GloBE income for the Fiscal Year and has no Covered Taxes. Article 7.4.5 computes 13.5 of Top-up Tax based on the Constituent Entity's share of the income, or 90. The Parent Entity's Inclusion Ratio is 1.0 and thus the Parent Entity is allocated all 13.5 of the Investment Entity's Top-up Tax.

Article 7.4.6

87. Generally, only Eligible Tangible Assets and Eligible Payroll Costs of Eligible Employees of the Investment Entities located in the jurisdiction are included in the calculation of the Substance-based Income Exclusion. Article 7.4.6 provides a special rule for computing the Substance-based Income Exclusion of Investment Entities. Article 7.4.6 reduces the Substance-based Income Exclusion proportionally to correspond to the MNE Group's Allocable Share of the Investment Entity's or Insurance Investment Entity's GloBE Income or Loss. If there are multiple Investment Entities located in the same jurisdiction, their Substance-based Income Exclusions are combined and offset against the Net GloBE Income of those Entities to determine their aggregate Excess Profit.

88. Article 7.4.6 applies notwithstanding the rule in Article 5.3.2, which generally excludes assets and payroll expenses of an Investment Entity or Insurance Investment Entity from the computation of the Substance-based Income Exclusion. The rule in Article 5.3.2 is intended to prevent those assets and payroll expenses from being included in the computation of the carve-outs for both the jurisdiction and the Investment Entity or Insurance Investment Entity.

Article 7.5 - Investment Entity Tax Transparency Election

Article 7.5.1

89. Article 7.5.1 provides a Five-Year election to treat an Investment Entity or Insurance Investment Entity as a Tax Transparent Entity. The election is available to Constituent Entity-owners of Investment Entities or Insurance Investment Entities that are subject to a mark-to-market or similar tax regime on investments in Investment Entities and Insurance Investment Entities. The treatment as a Tax Transparent Entity applies for all purposes of the GloBE Rules, including Article 3.5.

90. Under Article 10.1, Investment Entities are defined as Entities that meet the definition of an Investment Fund or Real Estate Investment Vehicle. Article 10.1 defines an Insurance Investment Entity as an Entity that would qualify as an Investment Fund or Real Estate Investment Vehicle but for the fact that it is wholly-owned by an insurance company and established in relation to liabilities under one or more insurance or annuity contracts. An Insurance Investment Entity may be wholly-owned by a single Entity, or by a number of Entities which are all part of the same MNE Group. The definition also requires that the owner, or owners, are subject to regulation as insurance companies. This requirement may also be met if the Insurance Investment Entity is owned by a Flow Through Entity which is subject to regulations in the same manner as an insurance company. If an election under Article 7.5.1 is made with respect to an Investment Entity or an Insurance Investment Entity, the rules in Article 7.4 do not apply.

91. The election, which is made by the Filing Constituent Entity, is only available where the Constituent Entity-owner is subject to tax in its location on changes in the value of its interest in the Investment Entity or Insurance Investment Entity (or its underlying investments) under a mark-to-market or similar regime at a rate that equals or exceeds the Minimum Rate. The election does not need to be made with respect to all Constituent Entity-owners of the Investment Entity. However, the election applies to all of a Constituent Entity-owner's interests in the Investment Entity.

92. By treating the Investment Entity as tax transparent, the election allows the MNE Group to include the Constituent Entity-owner's share of the Investment Entity's results as income of the Constituent Entity-owner for GloBE purposes. This election matches the timing and location of income earned through an Investment Entity under the GloBE Rules and the local tax rules where the Constituent Entity-owner is subject to a mark-to-market or similar regime.

93. The election is available for both directly owned Investment Entities and Insurance Investment Entities as well as such Entities that are indirectly owned through other Investment Entities or Insurance Investment Entities. Thus, the tax effect of changes in value of a lower-tier Investment Entity or Insurance Investment Entity in a chain of such Entities that is reflected in the valuation of the interest in a directly held Investment Entity or Insurance Investment Entity can be matched with the GloBE Income or Loss of that Entity. The tax method and the financial accounting method of computing fair value may not be exactly the same, and thus, there may be timing differences even with the election. However, those differences will occur less frequently and in smaller amounts.

94. The Constituent Entity-owner's share of the GloBE Income or Loss of the Investment Entity or the Insurance Investment Entity should not be counted twice by the Constituent Entity-owner. Only the Constituent Entity-owner's share of the GloBE Income or Loss computed for the Investment Entity or Insurance Investment Entity should be taken into account pursuant to an election under Article 7.5. The income of the Investment Entity or Insurance Investment is likely to be determined using fair value accounting in the preparation of the Consolidated Financial Statements.

95. The Constituent Entity-owner should not account for its Ownership Interest in a Constituent Entity that is an Investment Entity or an Insurance Investment Entity using a fair value accounting method, even if, on a separate entity accounting basis, the Constituent Entity-owner does not control the Investment Entity or Insurance Investment Entity. The Constituent Entity-owner's Financial Accounting Net Income or Loss should be determined pursuant to Chapter 3 using the accounting standard that was used to determine the Constituent Entity's income in preparing the Consolidated Financial Statements. However, if for some reason the Constituent Entity-owner did account for its interest in the Investment Entity or Insurance Investment Entity using a fair value method, that income or loss should be excluded from the computation of its GloBE Income or Loss.

96. For example, assume that UPE owns 100% of the Ownership Interests of CE1 and CE2, and CE1 and CE2 own 90% and 10%, respectively, of the Ownership Interests in Fund, an Insurance Investment Entity. Fund earns 100 of net income in Year 1, pays no tax, and makes no distributions. An election under Article 7.5 is made on behalf of CE1 and CE2. Accordingly, CE1 and CE2 include their share of Fund's income, 90 and 10, respectively, in the computation of their GloBE Income or Loss. On a standalone basis, CE1 controls Fund and thus would consolidate its accounts even if CE2 were an unrelated company. CE2, on the other hand, owns only 10% of Fund and on a standalone basis might be required to apply fair value accounting to its interest in Fund under the Acceptable Financial Accounting Standard used in the Consolidated Financial Statements. For purposes of the GloBE Rules, however, CE2 does not include any fair value gains or distributions from Constituent Entities. Otherwise, in this case, CE2 would recognise 10 of fair value gain in addition to the 10 of income included in its income under the Article 7.5 election.

97. In addition, the election allows the Constituent Entity-owner to apply the Substance-based Income Exclusion with respect to its share of the income of the Investment Entity. In many cases, the MNE Group's Eligible Payroll Expenses and Eligible Tangible Assets related to managing the Investment Entity's or Insurance Investment Entity's activities will not arise in the Investment Entity or Insurance Investment Entity itself, but instead will be those of the Constituent Entity-owners.

Article 7.5.2

98. Article 7.5.2 provides that the Article 7.5.1 election is a Five-Year Election. Article 7.5.2 further provides transition rules for revocation of the election. If the election is revoked, gains or losses from the disposition of an asset or liability held by the Investment Entity shall be determined based on the fair value of the assets or liabilities on the first day of the revocation year. The fair value at the beginning of the revocation year is the starting point. If the Investment Entity's income is determined using a realisation method, that value will continue to be the value of the asset for purposes of determining gains or losses under the GloBE Rules until it is disposed. If, on the other hand, the Investment Entity's income is determined using a fair value method for the assets, then that method will re-value the assets at regular intervals and include the gains or losses in Financial Accounting Net Income or Loss. That re-valuation will apply for GloBE purposes as well.

Article 7.6 - Taxable Distribution Method Election

99. Article 7.6 provides another alternative to the rule in Article 7.4. This alternative is the Taxable Distribution Method. This method reduces the exposure to Top-up Tax to the extent that the Investment Entity makes distributions of its income within a four-year period that are taxable in the hands of the recipients at or above the Minimum Rate.

Article 7.6.1

100. Article 7.6.1 provides for a Five-Year election to use the Taxable Distribution Method. The election is made by the Filing Constituent Entity and is only available in the case of the Constituent Entity-owners that are subject to tax in their location on distributions from the Investment Entity and only if the Constituent Entity-owner can be reasonably expected to be subject to tax on such distributions at a rate that equals or exceeds the Minimum Rate. The election need not be made with respect to all Constituent Entity-owners of the Investment Entity. However, the election applies to all of the Constituent Entity-owner's Ownership Interests in the Investment Entity.

Article 7.6.2

101. Article 7.6.2 sets out the operation of the Taxable Distribution Method.

102. Paragraph (a) requires the Constituent Entity-owner to include actual and deemed distributions in the computation of its GloBE Income in the Fiscal Year for which it is subject to tax on the distribution. The GloBE Rules do not have an independent definition of deemed distribution, although Article 7.6.5(c) treats certain transfers of an Ownership Interest as a deemed distribution. The reference to deemed distribution in paragraph (a) is intended to ensure that the Taxable Distribution Method is coordinated with the tax treatment under local tax rules. Thus, deemed distributions under the Taxable Distribution Method are generally determined by reference to the law applicable to the Constituent Entity-owner. This feature of the Taxable Distribution Method is a departure from the ordinary GloBE Rules, where distributions from Constituent Entities are excluded from GloBE Income. The Taxable Distribution Method is intended to match both the timing and location of the income earned by an MNE Group through the Investment Entity with the tax on that income in the location where the Constituent Entity-owner is subject to tax on the distributions.

103. A Constituent Entity-owner that is itself an Investment Fund, i.e. an intermediate Investment Fund, does not include the distribution in its GloBE Income or Loss, to preserve the tax neutrality of Investment Entities. However, distributions to intermediate Investment Entities do not re-start the four-year clock on distributions to the Constituent Entity-owner for which the election is made. As explained below,

distributions do not reduce the Undistributed Net GloBE Income until they reach a Constituent Entity that is not an Investment Entity.

104. Paragraph (b) requires the Constituent Entity-owner to include the Local Creditable Tax Gross-up in its GloBE Income and Adjusted Covered Taxes. The Local Creditable Tax Gross-up is defined in Article 7.6.5(d). It is generally the amount of Covered Taxes paid by the Investment Entity that is allowed as a credit in the computation of the Constituent Entity-owner's tax liability in respect of a distribution from the Investment Entity. Rather than creating a separate regime for tracking and managing Covered Taxes associated with each Constituent Entity-owner's share of the Investment Entity's GloBE Income that is subject to the Taxable Distribution Method, the GloBE Rules rely on the tax credit rules in the Constituent Entity-owner's location. Thus, the rule effectively provides credit for Covered Taxes paid by the Investment Entity under the GloBE Rules to the same extent a credit is allowed for local tax purposes. The rule also requires that the Local Creditable Tax Gross-up be treated as additional GloBE Income so that the tax credit does not have the same effect as allowing both a deduction and a credit.

105. Paragraph (c) provides that the Constituent Entity-owner's proportionate share of the Investment Entity's Undistributed Net GloBE Income is treated as GloBE Income of the Investment Entity for the Reporting Fiscal Year and the result of multiplying the Minimum Rate by such GloBE Income is treated as Top-up Tax of a Low-Tax Constituent Entity in the Fiscal Year for purposes of Chapter 2. Liability for this Top-up Tax is determined pursuant to Chapter 2.

106. Finally, to achieve the intended result of attributing income (and tax consequences) of the Investment Entity to the Constituent Entity-owners rather than the Investment Entity, Article 5.1.3 requires that the Investment Entity's GloBE Income or Loss for the Fiscal Year, and any Adjusted Covered Taxes attributable to such income, are excluded from all ETR computations under Chapter 5 and Articles 7.4.1 to 7.4.5, except to the extent the Adjusted Covered Taxes are included in the Constituent Entity-owners GloBE Income or Loss and Adjusted Covered Taxes pursuant to paragraph (b) of the Article.

Article 7.6.3

107. Article 7.6.3 defines the Undistributed Net GloBE Income and Article 7.6.4 provides additional rules to prevent double counting and to allow loss carry forwards.

108. Generally, the definition of Undistributed Net GloBE Income tests whether the GloBE Income arising in the Tested Year was distributed or offset by losses by the end of the Testing Period. Thus, as a practical matter, the MNE Group must maintain an Undistributed Net GloBE Income account for each Tested Year. The Undistributed Net GloBE Income is calculated for the entire Investment Entity, but Top-up Tax is computed based on the Constituent Entity-owner's share of the Undistributed Net GloBE Income.

109. Under Article 7.6.5, the Tested Year is the third Fiscal year preceding the Reporting Fiscal Year. The Testing Period is the four-year period beginning with the Tested Year and ending with the Reporting Fiscal Year. For example, if the Investment Entity fully distributed its GloBE Income to its Constituent Entity-owners over the course of this four year period, no Top-up Tax could be imposed under the Taxable Distribution Method. The owner could of course be subject to Top-up Tax in one of those years based on its own circumstances.

110. The definition of Undistributed Net GloBE Income in Article 7.6.3 starts with the GloBE Income for the Tested Year, if any. If there is zero GloBE Income or a GloBE Loss for a Fiscal Year, the Undistributed Net GloBE Income for such year is zero and remains zero while that year is in the Testing Period.

111. Once established, the Undistributed Net GloBE Income account for a Tested Year is reduced first by the amount of Covered Taxes, if any, paid by the Investment Entity. This is necessary because the distributable earnings of the Investment Fund would be reduced by Covered Taxes. However, Covered Taxes are added back to the Financial Accounting Net Income or Loss in the computation of GloBE Income

or Loss. Consequently, without this adjustment, all of an Investment Entity's GloBE Income would not be distributable. The Investment Entity's Covered Taxes are, however, subsequently included in the Adjusted Covered Taxes of the Constituent Entity-owner to the extent they are included in the Local Creditable Tax Gross-up associated with a distribution or deemed distribution.

112. The Undistributed Net GloBE Income is further reduced by distributions to shareholders other than Constituent Entities that are Investment Entities and deemed distributions. Distributions to all other shareholders, including non-Group Entities, reduce the Undistributed Net GloBE Income. Distributions to Constituent Entities that are Investment Entities reduce Undistributed Net GloBE Income only when they are further distributed to a non-Investment Entity. MNE Groups may use any reasonable method of determining whether distributions through a chain of Investment Entities are distributed to a non-Investment Entity. For example, an MNE Group may treat distributions of an Investment Entity as being first attributable to distributions received from other Investment Entities of the MNE Group.

113. Undistributed Net GloBE Income is also reduced for losses because losses reduce the amount that can be distributed as a dividend. Paragraph (c) reduces Undistributed Net GloBE Income by losses that arise during the Testing Period. However, if the losses arising in the Testing Period exceed the Undistributed Net GloBE Income accounts, an Investment Loss carry-forward must be created to reduce the Undistributed Net GloBE Income arising in subsequent Fiscal Years.

Article 7.6.4

114. The Undistributed Net GloBE Income account for the Tested Year is reduced by distributions during the Testing Period to the extent such distributions were not treated as reducing the Undistributed Net GloBE Income account for a previous Tested Year. Thus, distributions only reduce Undistributed Net GloBE Income of one year; they cannot be double-counted.

115. The Undistributed Net GloBE Income is further reduced by GloBE Losses, if any, arising in the Testing Period and any Investment Loss Carry-forward from a prior period. Investment Loss Carry-forwards are the amount of GloBE Losses arising before the Tested Year that were not completely absorbed, i.e. reduced to zero, before the loss year rolled out of the Testing Period. For purposes of computing Undistributed Net GloBE Income, GloBE Losses are reduced when they are used to reduce Undistributed Net GloBE income and thus cannot be used to reduce the Undistributed Net GloBE Income of another Tested Year.

116. If the MNE Group has not owned an interest in the Investment Entity for three consecutive years, the GloBE Income for each preceding year that it did not own an interest is considered to be zero for purposes of determining the Undistributed Net GloBE Income. Accordingly, there will not be any Undistributed Net GloBE Income for the first three years in which the MNE Group owns an interest in the Investment Entity.

Article 7.6.5

117. Article 7.6.5 contains definitions related to the Taxable Distribution Method.

- a. Paragraph (a) defines Tested Year as the third year preceding the Reporting Fiscal Year.
- b. Paragraph (b) defines Testing Period as the four-year period beginning with the Tested Year and ending with the Reporting Fiscal Year. These definitions are important to the determination of an Investment Entity's Undistributed Net GloBE Income. These definitions, together with the other provisions of Article 7.6.3, allow distributions in the Tested Year and the three succeeding Fiscal Years to reduce the Undistributed Net GloBE Income of the Investment Entity.
- c. Paragraph (c) treats a transfer of a direct or indirect Ownership Interest in the Investment Entity to a person that is not a Group Entity as a deemed distribution. The amount of the deemed

distribution is determined based on the proportional decrease in the transferring Constituent Entity's Ownership Interest. This rule applies irrespective of whether the Constituent Entity-owner that transferred its interest is subject to tax as a result of the transfer. Without this rule, the Undistributed Net GloBE Income attributable to the disposed Investment Entity would continue to be deferred until the end of the Testing Period.

- d. Paragraph (d) defines the Local Creditable Tax Gross-up as the amount of Covered Taxes incurred by the Investment Entity that is allowed as a credit against the Constituent Entity-owner's tax liability arising in connection with a distribution from the Investment Entity. The Local Creditable Tax Gross-up is discussed in the Commentary to Article 7.6.2(b).

Notes

¹ The application of Article 7.1.1(a) is illustrated in the Examples to the Commentary on the Model GloBE Rules under Pillar Two: <https://www.oecd.org/tax/beps/tax-challenges-arising-from-the-digitalisation-of-the-economy-global-anti-base-erosion-model-rules-pillar-two-examples.pdf>.

² The application of Article 7.1.4 is illustrated in the Examples to the Commentary on the Model GloBE Rules under Pillar Two: <https://www.oecd.org/tax/beps/tax-challenges-arising-from-the-digitalisation-of-the-economy-global-anti-base-erosion-model-rules-pillar-two-examples.pdf>.

³ The application of Article 7.3.4 is illustrated in the Examples to the Commentary on the Model GloBE Rules under Pillar Two: <https://www.oecd.org/tax/beps/tax-challenges-arising-from-the-digitalisation-of-the-economy-global-anti-base-erosion-model-rules-pillar-two-examples.pdf>.

8 Administration

Article 8.1 - Filing obligation

1. Article 8.1 sets out the requirements for the filing of a GloBE Information Return. The GloBE Information Return is a return in a standardised template form that provides a tax administration with the information it needs to evaluate the correctness of a Constituent Entity's tax liability under the GloBE Rules. The rules set out in Article 8.1 do not seek to harmonise tax filing and payment obligations for the GloBE Rules themselves. They aim to provide core information to jurisdictions implementing the GloBE Rules information reporting requirements. The operation of tax filing and payment obligation rules, including, for example, late payment interest and time limits for auditing and correcting return, is left to the determination of each implementing jurisdiction based on the design of that jurisdiction's existing tax filing and payment procedures.

2. The GloBE Rules should be implemented and administered in such a way that any Top-up Tax liabilities incurred are due and paid within a reasonable period and in line with the intended outcomes under the GloBE Rules and the Commentary.

3. Article 8.1 places an obligation on each Constituent Entity to file a GloBE Information Return with the local tax administration. This return can be filed by each Constituent Entity directly with its local tax administration or through a Designated Local Entity on behalf of one or more Constituent Entities located in the same jurisdiction. Article 8.1 also recognises, however, that a Constituent Entity may not be in the best position to collect the information necessary to complete the GloBE Information Return, particularly if most of the information on that return concerns other members of the MNE Group. In many cases, it is expected that the UPE or a Designated Filing Entity appointed by the MNE Group, would be in a better position to collect such information, much of which may already be collected in the preparation of the MNE Group's Consolidated Financial Statements.

4. Accordingly, while Article 8.1 places an obligation on each Constituent Entity to file a GloBE Information Return with the tax administration of the jurisdiction where it is located, a Constituent Entity is under Article 8.1.2 discharged from this obligation when the UPE or a Designated Filing Entity files the GloBE Information Return with the tax administration of the jurisdiction where it is located and the Competent Authority of that jurisdiction has a bilateral or multilateral agreement or arrangement in effect to automatically exchange the GloBE Information Return with the Competent Authority of the jurisdiction of the Constituent Entity. The Competent Authorities are the authorized representatives of those jurisdictions that are parties to a Tax Treaty, tax information exchange agreement, or the Convention on Mutual Administrative Assistance in Tax Matters that by its terms provides legal authority for the exchange of tax information between jurisdictions, including automatic exchange of such information. In this way the return filing obligations operate so that the UPE or a Designated Filing Entity of the MNE Group can file a single GloBE Information Return covering all Constituent Entities in the MNE Group, which can be provided to all tax administrations with a Constituent Entity(ies) located in their jurisdiction through appropriate international exchange mechanisms.

Article 8.1.1

5. Under the first sentence of Article 8.1.1, each Constituent Entity of an MNE Group would be required to prepare a GloBE Information Return and file it with its tax administration. Where there are two or more Constituent Entities located in the same jurisdiction, the second sentence of Article 8.1.1 allows one of them, i.e., the Designated Local Entity, to file a single GloBE Information Return on behalf of the others (and itself). When a Designated Local Entity files a GloBE Information Return on behalf of other Constituent Entities located in the same jurisdiction, the obligation of those Constituent Entities to file their own return is discharged. Although Article 8.1 places the default filing obligation on each local Constituent Entity, it would be acceptable for implementing jurisdictions to make a Designated Local Entity the sole Constituent Entity that is legally responsible for this filing obligation, provided this approach achieves the intended purpose of ensuring an information return is filed on behalf of the MNE Group.

6. The first sentence of Article 8.1.1 requires a Constituent Entity located in the implementing jurisdiction to file the GloBE Information Return. A Stateless Constituent Entity, such as a Flow-through Entity that is not a UPE, would not be required to file this return because it is not located in the implementing jurisdiction. For example, a partnership that is a Flow-through Entity and is not treated as tax resident in the jurisdiction where it is organized would not generally be required to submit a GloBE Information Return. In most cases this is consistent with its tax treatment in the jurisdiction where it was organized. However, the Constituent Entity-owners of the Flow-through Entity would be required to submit a GloBE Information Return as would any other Constituent Entity located in a jurisdiction by virtue of the first sentence of Article 8.1.1. Where the Flow-through Entity is the UPE or is required to apply the IIR, it would be located in the jurisdiction where it was created in accordance with Article 10.3.2(a) and therefore, it would be required to submit a GloBE Information Return. In these cases, the GloBE Information Return could be filed by an authorised entity such as a trustee or manager on behalf of the Flow-through Entity. Similarly, PEs are Constituent Entities required to file a GloBE Information Return in the jurisdiction where they are located.

7. In some cases, a Flow-through Entity may have some formal obligations under domestic tax law such as submitting information returns. In these situations, jurisdictions are free to extend the obligation in Article 8.1.1 to such Entities provided that they are created under their domestic law.

8. An Entity treated as a JV in the Consolidated Financial Statements of an MNE Group is not required to submit a GloBE Information Return in accordance with Article 8.1.1, because it is not a Constituent Entity of that MNE Group despite being treated as such solely for purposes of the computation of its Top-up Tax in accordance with Article 6.4.1 (a). For the same reasons, an Entity treated as a JV Subsidiary by an MNE Group is not required to submit a GloBE Information Return for that Group.

Article 8.1.2

9. Article 8.1.2 states that all Constituent Entities (including the Designated Local Entity) are discharged from the requirement to file a GloBE Information Return if the return has been filed by the UPE or by a Designated Filing Entity appointed by the MNE Group provided that the Competent Authority of the jurisdiction in which the Filing Constituent Entity is located has a Qualifying Competent Authority Agreement with the Competent Authority of the jurisdiction where the Constituent Entity is located. Thus, by reason of the Qualifying Competent Authority Agreement, the Competent Authority of the jurisdiction where the Constituent Entity is located should obtain the GloBE Information Return on an automatic basis from the Competent Authority of the jurisdiction where the UPE or Designated Filing Entity is located.

10. The information exchange mechanism allowed under Article 8.1.2 means that many, and perhaps most, tax administrations will receive the GloBE Information Return through an exchange of information mechanism and that a local filing obligation will only apply, in practice, where the return has not otherwise been filed in a jurisdiction with a Qualifying Competent Authority Agreement. The Qualifying Competent Authority Agreement mechanism allows the MNE Group to minimise compliance burdens by having the

UPE, or appointing a single Designated Filing Entity, to prepare and file the GloBE Information Return centrally for distribution to tax administrations in other jurisdictions. While in many cases the UPE will fulfil this function of filing returns on behalf of the Group Entities, there may be reasons why another Constituent Entity is better placed to do so and, therefore, the MNE Group may appoint another Constituent Entity as the Designated Filing Entity. For example, the jurisdiction where the Designated Filing Entity is located may have a wider network of international exchange agreements in effect and therefore a greater ability to reduce the local filing obligations throughout the MNE Group.

11. The term “Qualifying Competent Authority Agreement” is defined in Article 10.1. It means a bilateral or multilateral agreement or arrangement between Competent Authorities that provides for annual automatic exchange of information that is included in the GloBE Information Return. Bilateral and multilateral models for the Qualifying Competent Authority Agreement would be developed as part of the GloBE Implementation Framework and would be based on the Convention on Mutual Administrative Assistance in Tax Matters, a Tax Information Exchange Agreement, a Tax Treaty with a provision equivalent to Article 26 of the OECD Model Tax Convention or any other international agreement that allows automatic exchange of information. In order to prevent the MNE Group from being required to file a GloBE Information Return in each of the jurisdictions where it has a Constituent Entity, jurisdictions adopting the GloBE Rules are encouraged to enter into Qualifying Competent Authority Agreements with interested appropriate partners adopting the GloBE Rules. If a Competent Authority has not received the GloBE Information Return in accordance with a Qualifying Competent Authority Agreement, and the Competent Authority has complied with the applicable notification and other procedures in the Qualifying Competent Authority Agreement, then, subject to the terms of the Qualifying Competent Authority Agreement, the conditions in Article 8.1.2 would not be met. To provide notification to Constituent Entities, each jurisdiction should publish and periodically update a list of the jurisdictions of the Competent Authorities with respect to which it has Qualifying Competent Authority Agreements in effect.

Article 8.1.3

12. Article 8.1.3 requires a Constituent Entity (either directly or through a Designated Local Entity) to notify its local tax administration of the identity and location of the UPE or the Designated Filing Entity that will be filing the GloBE Information Return. This provides the tax administration with notice that it will receive the return through information exchange channels.

Article 8.1.4

13. Article 8.1.4 states that the GloBE Information Return has to be filed in a standard template that is developed in accordance with the GloBE Implementation Framework and sets out the items of information that should be included in the GloBE Information Return. As indicated below, the information required by the GloBE Information Return could be specified, expanded or restricted in accordance with the GloBE Implementation Framework. While Article 8.1.4 relates to information in the GloBE Information Return, it is not intended to prevent a local tax administration from requesting further necessary supporting information to verify the compliance to the GloBE Rules in accordance with its domestic law. It is anticipated that a standard template of the GloBE Information Return that is developed in accordance with the GloBE Implementation Framework will contain fields for all of the required information.

14. Paragraph (a) requires the GloBE Information Return to identify the Constituent Entities of the MNE Group, their location, and their tax identification numbers (if they exist). It also requires the GloBE Information Return to identify their status under the GloBE Rules (e.g., a POPE, JV, JV subsidiary, Investment Entity, Flow-through Entity, and PE). For example, it should identify the Designated Filing Entity (if any) and whether an Entity qualifies as Investment Entity under the GloBE Rules. Stateless Constituent Entities should be identified pursuant to paragraph (a).

15. Paragraph (b) requires the GloBE information Return to include information on the overall corporate structure of the MNE Group. As part of the GloBE Implementation Framework, it will be decided whether the overall corporate structure of the MNE Group is included as a diagram and/or as a list so that tax administrations can identify how the corporate structure of the MNE Group is organized. It shall identify which Constituent Entities are holding the Controlling Interests of other Constituent Entities. If the corporate structure changes during the Fiscal Year, the diagram and/or list shall identify those changes.

16. Paragraph (b) requires information on the overall corporate structure of the MNE Group, which would include Entities that are Excluded Entities when they are part of such Group. In these situations, paragraph (b) also requires that these Excluded Entities are identified within the corporate structure notwithstanding that they are not Constituent Entities. The information provided in accordance with this paragraph only reflects how the corporate structure of the MNE Group is organized. For example, the information on the corporate structure does not provide information on an Excluded Entity other than the information that is necessary to identify the location of the Excluded Entity in the overall corporate structure.

17. Paragraph (c) requires the GloBE Information Return to include the information needed to compute the ETR (including the Financial Accounting Net Income or Loss, the type and amount of the adjustments applied in conformity with Article 3.2 to determine the GloBE Income or Loss, and the amount of Covered Taxes) and the Top-up Tax of Constituent Entities and any JV or JV Subsidiary. For example, this may also include the information required for purposes of applying the De Minimis Exclusion, if elected under Article 5.5.1 or a GloBE Safe Harbour elected under Article 8.2.

18. Paragraph (c) also requires that the GloBE Information Return contains the Top-up Tax allocation under the IIR and UTPR in each jurisdiction as provided for under Chapter 2. The following paragraphs identify information that must be included in the GloBE Information Return with respect to the Top-up Tax allocation under the IIR and the UTPR in each jurisdiction, but other information may be necessary as well.

19. In the case of the IIR, the GloBE Information Return should include the information necessary to compute the allocation of the Top-up Tax in accordance with the top-down approach and split-ownership rules of Article 2.1. Furthermore, the GloBE Information Return should include the information for determining the Parent Entity's Allocable Share of the Top-up Tax of each LTCE in accordance with Article 2.2. Lastly, the GloBE Information Return should include the information and computation of the reduction of Top-up Tax under Article 2.3 due to the application of a Qualified IIR by a lower-tier Parent Entity.

20. In the case of the UTPR, the GloBE Information Return should include the information necessary to determine the Total UTPR Top-up Tax Amount for a Fiscal Year in accordance with Article 2.5.1 and the allocation of that amount among UTPR Jurisdictions in accordance with Article 2.6. The GloBE Information Return should include the basis for allocation of the Total UTPR Top-up Tax Amount for the Reporting Fiscal Year, including the relevant information on Number of Employees and Tangible Assets necessary to apply the formula provided under Article 2.6.1. The return should also report the amount of Top-up Tax carried forward from a prior taxable year when the UTPR adjustment in a UTPR Jurisdiction has not yet resulted in an additional cash tax expense equal to the Top-up Tax amount for the Constituent Entities located in that jurisdiction. Furthermore, the return should report the amount of the additional cash tax expense that results from the application of the UTPR under Article 2.4.1 and any amount of Top-up Tax that needs to be carried forward to the next taxable year in accordance with Article 2.4.2.

21. Paragraph (d) requires information regarding any elections made in accordance with the relevant provisions of the GloBE Rules, such as, the elections made in accordance with Article 5.5.1 with respect to the De Minimis Exclusion.

22. Paragraph (e) requires the inclusion of other information necessary to carry out the administration of the GloBE Rules and that is agreed as part of the GloBE Implementation Framework. However, as stated at the beginning of Article 8.1.4, the information contained in the GloBE Information Return could be then specified, expanded or restricted in accordance with the GloBE Implementation Framework.

Furthermore, this could include the development of a simplified reporting procedure in cases where not all the information is required for the purpose of assessing the application of the GloBE Rules.

23. Generally, information on Excluded Entities shall not be included in the GloBE Information Return because such Entities will not be Constituent Entities of an MNE Group and will therefore be outside the scope of the GloBE Rules. If the whole MNE Group is composed exclusively of Excluded Entities and therefore outside the scope of the GloBE Rules, then there is no obligation to submit a GloBE Information Return because there are no Constituent Entities required to submit a GloBE Information Return under Article 8.1.1. In other cases, where Excluded Entities form part of an MNE Group that is within the scope of the GloBE Rules, Article 8.1.4(b) will generally require those Excluded Entities to be identified as part of the overall corporate structure. Guidance developed under the GloBE Implementation Framework could further specify, expand or restrict the information requirements in respect of such Entities. Any information requirements with respect to Excluded Entities developed under the GloBE Implementation Framework should be limited to what is reasonably necessary for the proper administration of the GloBE Rules and in line with requirements of public policy. For example, the Excluded Entity could provide a certification by the tax authority of the jurisdiction where the Excluded Entity is established or resident.

Article 8.1.5

24. Article 8.1.5 states that the GloBE Information Return shall apply the definitions and instructions contained in the standard template that is developed in accordance with the GloBE Implementation Framework. These definitions and instructions would be developed by the members of the Inclusive Framework on BEPS.

Article 8.1.6

25. In order to allow MNE Groups time to prepare the required information, Article 8.1.6 provides MNE Groups with up to 15 months after the last day of the Reporting Fiscal Year to file the GloBE Information Return and the notifications with the relevant tax administrations. The timing for filing notifications is aligned with the timing for filing the GloBE Information Return (i.e. within 15 months after the last day of the Reporting Fiscal Year). This gives a Constituent Entity or a Designated Local Entity ample opportunity to notify its local tax administration of the identity and location of the UPE or Designated Filing Entity that will be filing the GloBE Information Return on its behalf.

26. There is no special provision under Article 8.1 regarding amendments to a GloBE Information Return. It is left to jurisdictions to decide whether their current domestic rules regarding amendments to tax or information returns will apply to the GloBE Information Return, or to introduce new provisions that apply only to the GloBE Information Return. Further guidance will be provided as part of the GloBE Implementation Framework regarding amendments to the GloBE Information Return, including the time frame and the method for the filing and exchange of information between Competent Authorities.

Article 8.1.7

27. Article 8.1.7 provides that a tax administration may modify the information, filing and notification requirements in respect of the GloBE Information Return where this is agreed as part of the GloBE Implementation Framework. This provision is intended to provide some flexibility to jurisdictions and their tax administrations in the implementation of the filing and notification requirements that are developed under the GloBE Implementation Framework (including additional, simplified or modified filing requirements) but after the enactment of the legislation, regulations, or other guidance implementing the GloBE Rules. As with other aspects of these rules, however, jurisdictions may be constrained, due to their legislative or regulatory framework, to introduce amending legislation to change the filing requirements,

rather than relying on a delegated authority to the Ministry of Finance or its equivalent, or the tax administration.

Article 8.1.8

28. Article 8.1.8 requires that the laws of each jurisdiction with respect to penalties, sanctions, and confidentiality of the returns (including the information in the returns) shall also apply to the GloBE Information Return. In the case of penalties and sanctions, this means that domestic penalties and sanctions would apply if the GloBE Information Return is not submitted on time or if there is any false or incomplete information. Jurisdictions are free to extend existing penalties or sanctions (as well as any penalty or sanction mitigation provisions) or to create new ones for the GloBE Information Return. New penalties and sanctions in respect of the GloBE Information Return should be commensurate with penalties or sanctions in respect of other information returns and other information return filing obligations in the jurisdiction.

29. In the case of confidentiality of the returns the information gathered under the GloBE Information Return shall have at least the same level of protection as the information obtained through domestic tax or information returns. GloBE Information Returns received by a tax administration through exchange of information would further be subject to the confidentiality rules of the applicable Tax Treaty, tax information exchange agreement or other international agreement for the exchange of information.

Article 8.2 - Safe Harbours

30. It is likely that MNE Groups and tax administrations will incur incremental compliance and administration costs in respect of the application of the GloBE Rules. MNE Groups need to collect, adjust and aggregate information on a jurisdictional basis in order to identify and allocate Top-up Tax in respect of their operations in Low-Tax Jurisdictions. At the same time, tax administrations need to analyse the return information, assess risk areas, audit taxpayers and collect Top-up Tax that is brought into charge under the GloBE Rules in their jurisdiction. In order to limit unnecessary compliance and administrative burden for MNE Groups and tax administrations, the GloBE Implementation Framework will seek to explore the development of GloBE Safe Harbours. GloBE Safe Harbours would allow an MNE Group to avoid the ETR and Top-up Tax calculation in respect of its operations that are likely to be taxable at or above the Minimum Rate. They would also provide for improved tax certainty and transparency in the use of risk assessment under the GloBE Rules.

31. In anticipation of the GloBE Safe Harbours that may be developed as part of the GloBE Implementation Framework, the provisions of Article 8.2.1 would allow a Filing Constituent Entity to make an election with respect to Constituent Entities that qualify for that GloBE Safe Harbour. The effect of the GloBE Safe Harbour would be to exempt the MNE Group from the need to compute the jurisdictional ETR and allow a tax administration to deem the Top-up Tax for the Constituent Entities located in the safe harbour jurisdiction to be zero for a Fiscal Year when the MNE Group can demonstrate that those Constituent Entities meet the requirements of the GloBE Safe Harbour. While Article 8.2.1 allows the tax administration to treat such Constituent Entities as having zero Top-up Tax for the year, Article 8.2.2 provides for a coordinated and balanced framework under which another tax administration could challenge a taxpayer's election to apply a GloBE Safe Harbour in circumstances that may have materially affected the eligibility of the MNE Group for the relevant GloBE Safe Harbour.

Article 8.2.1

32. Article 8.2.1 and the definition of GloBE Safe Harbour contemplate that any GloBE Safe Harbour will be developed and released as part of the GloBE Implementation Framework. The terms of any GloBE

Safe Harbour agreed under the GloBE Implementation Framework would specify the conditions that an MNE Group would need to meet in order to be able to rely on that GloBE Safe Harbour. These conditions would be designed to limit compliance costs for MNE Groups as well as administrative burden for tax authorities and incorporate thresholds that ensure only those parts of the MNE Group's operations that are nearly certain to have jurisdictional ETRs above the Minimum Rate would be eligible for the GloBE Safe Harbour. The GloBE Implementation Framework could also explore whether a GloBE Safe Harbour could cover the situations where no Top-up Tax would be due (for instance, in respect of a jurisdiction where MNE Groups are subject to a Qualified Domestic Minimum Top-up Tax).

33. If a Filing Constituent Entity elects to apply any GloBE Safe Harbour to the MNE Group's operations in a jurisdiction that would be eligible for the GloBE Safe Harbour, then the Top-up Tax for this jurisdiction would be deemed to be zero for the Fiscal Year of the election. The election for a GloBE Safe Harbour would be made on an annual basis. An MNE Group that elects to apply the GloBE Safe Harbour in respect of its Constituent Entities in a jurisdiction (the safe harbour jurisdiction) should not be required to compute the jurisdictional ETR for those Constituent Entities under Chapters 3-5 but should provide a record of the election to use the GloBE Safe Harbour, identify all the Constituent Entities in the safe harbour jurisdiction and provide any other relevant information, as part of the GloBE Information Return, consistent with Article 8.1.4 (a), (d) and (e).

Article 8.2.2

34. Where an MNE Group elects to apply a GloBE Safe Harbour, a tax administration could apply its ordinary assessment, investigation and audit processes to determine whether the GloBE Safe Harbour was applied in accordance with any criteria set out in the GloBE Implementation Framework and to assess the reasonableness of underlying data used for purposes of the GloBE Safe Harbour. Having done so, Article 8.2.2 provides a tax administration with a specific framework that would allow the tax administration to challenge the use of a GloBE Safe Harbour where specific facts and circumstances may have materially affected the eligibility of the Constituent Entities for the relevant GloBE Safe Harbour.

35. Article 8.2.2(a) provides that only a jurisdiction that could be allocated Top-up Tax under the GloBE Rules if the ETR of the safe harbour jurisdiction was below the Minimum Rate could challenge the use of a GloBE Safe Harbour with respect to the safe harbour jurisdiction. This paragraph ensures that the only jurisdictions that could challenge the use of a GloBE Safe Harbour are those that are affected by their use, that is those jurisdictions that would otherwise be allocated Top-up Tax if not for the use of a GloBE Safe Harbour. This paragraph would apply on an MNE Group-by-MNE Group basis and require testing whether the jurisdiction could be allocated Top-up Tax if the ETR of the safe harbour jurisdiction was below the Minimum Rate, by applying the allocation mechanics of the GloBE Rules and taking into account the MNE Group's structure. However, this paragraph by itself assumes that the ETR could be below the Minimum Rate and does not require the tax administration or the taxpayer to compute the ETR of the jurisdiction to test whether the ETR is below the Minimum Rate.

36. Article 8.2.2(b) provides that the tax administration that wishes to challenge the use of a GloBE Safe Harbour notifies the Liable Constituent Entity (or Entities) within 36 months after the GloBE Information Return is filed. The GloBE Implementation Framework should consider the date on which the 36 month-period is considered to start in circumstances where the GloBE Information Return is received through an information exchange mechanism or by multiple domestic Constituent Entities. The notification provides those specific facts and circumstances that may have materially affected the eligibility of the Constituent Entities for the relevant GloBE Safe Harbour. As provided in Article 10.1, the Liable Constituent Entities are those that could be liable for Top-up Tax (or subject to an adjustment under Chapter 2) in the jurisdiction of such tax administration if the GloBE Safe Harbour in Article 8.2.1 did not apply. While the tax administration should make its best efforts to notify all Liable Constituent Entities located in the jurisdiction, there may be circumstances where it would be enough to notify substantially all Liable

Constituent Entities, but not all of them, for instance because of a complex holding structure of the MNE Group in the jurisdiction. In addition, the tax administration may allow that only one of the Liable Constituent Entities of the MNE Group gives a response to the tax administration on behalf of the other Liable Constituent Entities, so that not all Liable Constituent Entities are required to give a response to the tax administration.

37. Article 8.2.2 (b) further provides that the Liable Constituent Entity (or Entities) is invited by the tax administration to clarify the effect of those facts and circumstances on the application of the GloBE Safe Harbour. The timeframe for clarifying the effect of those facts and circumstances is 6 months.

38. Article 8.2.2(c) provides that if the Liable Constituent Entity (or Entities) fails to demonstrate that the facts and circumstances identified by the tax administration did not affect materially the eligibility of the MNE for the GloBE Safe Harbour for this jurisdiction within the 6-month response period, the GloBE Safe Harbour would not be applicable. If the Liable Constituent Entity (or Entities), instead, demonstrates that the facts and circumstances identified by the tax administration did not affect materially the eligibility of the MNE for the GloBE Safe Harbour for the Constituent Entities located in the safe harbour jurisdiction, the GloBE Safe Harbour would still be applicable and the ETR of the jurisdiction would still be treated as if it was above the Minimum Rate.

39. The details of the consequences where the GloBE Safe Harbour is found not applicable as a result of Article 8.2.2 should be considered in the GloBE Implementation Framework.

Article 8.3 - Administrative Guidance

Article 8.3.1

40. Article 8.3.1 contemplates that further guidance on the interpretation or application of the GloBE Rules may be agreed and published by the Inclusive Framework. This Article ensures that when such guidance is issued, it is applied in a co-ordinated way.

41. There are a number of places in the GloBE Rules where determinations by one tax administration are likely to have corresponding consequences for the application of the GloBE Rules in other jurisdictions. In these cases, tax administrations can collaborate with each other through the Inclusive Framework to determine whether a co-ordinated solution to these questions can be agreed. If the discussions at the level of the Inclusive Framework result in the development of Agreed Administrative Guidance, then Article 8.3.1 provides that a tax administration should interpret and apply the GloBE Rules in accordance with that Agreed Administrative Guidance, subject to any other requirements under domestic law. For example, the domestic law of some Inclusive Framework members would not permit them to simply refer to that Agreed Administrative Guidance to interpret and apply the GloBE Rules. Their domestic law may instead permit the tax administration to adopt that Agreed Administrative Guidance by incorporating it verbatim or in substance into its own administrative guidance. Some Inclusive Framework members may need parliamentary acceptance of the Agreed Administrative Guidance before it could be used to interpret or apply the GloBE Rules.

9 Transition rules

Article 9.1 - Tax Attributes Upon Transition

1. Where an MNE Group has revenues in excess of the revenue threshold, it will become subject to the GloBE Rules after such rules are introduced into the domestic law of a jurisdiction in which the MNE Group operates. Smaller MNE Groups, however, will become subject to the GloBE Rules for the first time if they grow their revenues above the threshold, either organically or as a result of a merger or acquisition. A Constituent Entity could also become subject to the GloBE Rules for the first time when such Constituent Entity is acquired by a MNE Group that is already subject to the GloBE Rules.

2. At the point an MNE Group becomes subject to the GloBE Rules, it will be required, under a jurisdictional blending approach, to compute the ETR on its income in each jurisdiction where it operates and compare it to the Minimum Rate. Failure to take appropriate account of operating losses that the MNE Group has incurred in the period(s) prior to becoming subject to the GloBE Rules could result in a distorted picture of the MNE Group's tax position in that jurisdiction and may subject the MNE Group to taxation in excess of its economic profit. For example, a Constituent Entity may have incurred operating losses in the years prior to the MNE Group becoming subject to the GloBE Rules. Frequently, the operating losses of the Constituent Entity will also be recognised for local tax purposes and these losses may be eligible to be carried forward and be available to reduce taxable income arising in a future period in the same jurisdiction. Ignoring the effect of these prior period losses could result in an immediate GloBE tax on profits arising in subsequent periods despite the fact that, the local tax jurisdiction is otherwise a high-tax jurisdiction and that the income subject to charge under the GloBE Rules, represents, from the MNE Group's perspective, a recovery of prior period losses.

3. A similar transition-related issue arises in relation to timing differences that straddle the applicability date of the GloBE Rules. Of particular concern are those timing differences that result in the acceleration of income for tax purposes and hence taxes paid prior to an MNE Group being subject to the GloBE Rules, which then reverse after the MNE Group is subject to the GloBE Rules (i.e. the financial accounting income is reported after the MNE Group becomes subject to the GloBE Rules). These situations may arise, for example, when local law taxes pre-payments of contractual fees upon receipt rather than over the term of the contract or prohibits deductions for estimates of future bad debts or warranty expenses (i.e. reserves for bad debts or warranty expenses). Absent a corrective rule that takes account of pre-paid taxes in respect of that income, the result would be a lower GloBE ETR in the year(s) of reversal and thus potential GloBE Top-up Tax in those years, despite the fact that the local tax jurisdiction is otherwise a high-tax jurisdiction. Similarly, timing differences that defer tax on financial accounting income arising before the GloBE Rules apply would, absent a special rule, reduce the GloBE tax liability on GloBE income arising within the GloBE applicability period.

4. To address these concerns, Article 9.1 provides for transition rules. Consistent with the general mechanism to address temporary differences contained in Article 4.4, these transition rules build on deferred tax accounting concepts. The transition rules allow existing deferred tax accounting attributes, including deferred tax assets resulting from prior year losses, to be used in the calculation of the ETR to prevent distortions upon entry into the GloBE regime of a Constituent Entity of a MNE Group. As further

discussed below, the transition rules differ from the general mechanisms contained in Chapter 4 in some ways.

Article 9.1.1

5. Article 9.1.1 sets out the deferred tax accounting attributes of a Constituent Entity that may be utilised in calculating the ETR in a jurisdiction in the Transition Year and subsequent years. Rather than requiring an MNE Group to undertake complex calculations as if the Constituent Entity had been subject to the GloBE Rules in prior years, it uses a simplified approach that allows the MNE Group to take into account the deferred tax accounting attributes of the MNE Group at the beginning of the Transition Year, at the lower of the Minimum Rate or the applicable domestic tax rate. The applicable domestic tax rate is the rate at which an item of deferred tax expense has been recorded in the financial accounts. However, deferred tax assets in respect of GloBE Losses that have been recorded at a rate lower than the Minimum Rate may be recast at the Minimum Rate if the taxpayer can demonstrate that the deferred tax asset is attributable to a loss that would have been a GloBE Loss had the MNE Group been subject to the GloBE Rules in the year in which the loss arose. These attributes include losses that have not been recognised due to an accounting recognition adjustment or valuation allowance.

6. Article 9.1.1 provides the basis to use these attributes in determination of Covered Taxes pursuant to Article 4.4. Therefore, when a pre-existing deferred tax attribute is used for financial reporting purposes in a Fiscal Year in which the GloBE Rules apply, such attribute is available for use in the application of Article 4.4, subject to the limitations of Article 9.1. For example, if a Constituent Entity incurred a tax loss of (100) in a year before the GloBE applied, a deferred tax expense of (15) (i.e., deferred tax benefit) will be included in the Total Deferred Tax Adjustment Amount under Article 4.4 when the associated tax loss is used in a Fiscal Year in which the GloBE applies. The GloBE Implementation Framework will consider providing Agreed Administrative Guidance related to the measurement and treatment of items of deferred tax expense (i.e., deferred tax assets and deferred tax liabilities) in the Transition Year and subsequent years.

7. Attributes established under Article 9.1.1 are eliminated pursuant to Article 4.5.1 when a GloBE Loss Election is made under Article 4.5 because Article 4.4 does not apply when the GloBE Loss is elected under Article 4.5. The Transition Year is determined on a jurisdictional basis. As defined in Article 10.1, Transition Year, for a jurisdiction, means the first Fiscal Year in which the MNE Group comes within the scope of the GloBE Rules in respect of that jurisdiction. The phrase “in respect of that jurisdiction” is used in the definition rather than “of that jurisdiction” to make clear that the MNE Group’s Transition Year for a particular jurisdiction may be initiated due to the GloBE Rules of another jurisdiction.

Article 9.1.2

8. Article 9.1.2 provides a limitation to prevent the triggering of permanent difference losses before applicability of the GloBE Rules. An example of this would be a Constituent Entity that triggers a domestic tax loss with respect to an item that is not taken into account in the calculation of GloBE Income or Loss, such as depreciation deductions in excess of an asset’s cost. Absent the Article 9.1.2 limitation, such attribute would be imported into the GloBE attributes upon becoming subject to the rules. The limitation in Article 9.1.2 applies to any deferred tax asset generated in a transaction that takes place after 30 November 2021. Article 9.1.2 does not have retroactive tax implications, but rather sets out rules with respect to how certain attributes are taken into account in Fiscal Years to which the GloBE Rules apply.

9. The application of Article 9.1.2 is illustrated in the following example. In December, 2021, a Constituent Entity purchases an asset for 100. The jurisdiction in which the Constituent Entity is located imposes a 25% corporate income tax rate and allows for immediate expensing of the asset in 2021 and an additional 300 of tax depreciation with respect to such asset as a tax incentive that will be deducted in

the same Fiscal Year. After taking into account the deductions with respect to the asset, there is a domestic tax loss of 300 for which a deferred tax asset is established. As the deferred tax asset recorded with respect to the supplemental 300 domestic tax loss reverses, it is not included in Adjusted Covered Taxes under the application of this Article.

Article 9.1.3

10. Article 9.1.3 provides a limitation on intragroup asset transfers before applicability of the GloBE Rules. If an asset is transferred between entities after 30 November 2021 and before the Transition Year of a MNE Group, and such entities would have been Constituent Entities of that MNE Group had the GloBE Rules been in effect with respect to that MNE Group, such asset must be recorded at its historic carrying value for GloBE purposes to limit the ability to step-up the basis in such assets without including the resulting gain in the computation of GloBE Income or Loss. It follows that when this rule applies, because there is no change in asset basis, items of deferred tax expense with respect to such transaction will be recorded for GloBE purposes with respect to the historic carrying value of the assets transferred. The historic carrying value of the asset can easily be determined because the gain on the intra-group transfer and corresponding increased depreciation or amortization must be eliminated in the Consolidated Financial Statements. The rule in Article 9.1.3, however, does not apply to inventory because of the routine nature of intra-group inventory sales and the typically brief period that it is held before sale outside the MNE Group. Like Article 9.1.2, this Article does not have retroactive tax implications, but rather sets out rules with respect to how certain attributes are taken into account in Fiscal Years to which the GloBE Rules apply.

Article 9.2 - Transitional relief for the Substance-based Income Exclusion

Article 9.2.1 and 9.2.2 – Substance-based Income Exclusion

11. Article 9.2.1 provides the relevant percentages for the purpose of applying the payroll carve-out in Article 5.3.3 for Fiscal Years that begin in the transition period of ten calendar years beginning with 2023. For example, if a MNE Group has a Fiscal Year that commences on 1 March 2023, the applicable percentage to be applied for the Article 5.3.3 payroll carve-out in that Fiscal year is 10%.

12. This transition period applies regardless of when a MNE Group comes within the scope of the GloBE Rules. For example, if a MNE Group first becomes subject to the GloBE Rules in the Fiscal Year that commences on 1 January 2026, the applicable percentage to be applied for Article 5.3.3 in that Fiscal Year is 9.4%.

13. Article 9.2.2 provides the relevant percentages for the purpose of applying the tangible asset carve-out in Article 5.3.4 for Fiscal Years that begin in the transition period of ten calendar years beginning with 2023. The same principles described in the Article 9.2.1 Commentary apply with respect to Article 9.2.2.

Article 9.3 - Exclusion from the UTPR of MNE Groups in the initial phase of their international activity

14. Article 9.3 provides a transitional exclusion from the UTPR for MNE Groups that are in the initial phase of their international activity. Article 9.3.1 reduces to zero the Top-up Tax allocated under the UTPR for such MNE Groups. Article 9.3.2 then provides the criteria that an MNE Group must meet to be considered in the initial phase of its international activity. Article 9.3.3 provides the definition of the

Reference Jurisdiction that is used in Article 9.3.2. Finally, Article 9.3.4 provides for the time limitation of the application of Article 9.3.1.

Article 9.3.1

15. Article 9.3.1 provides an exclusion from the UTPR for MNE Groups that meet the requirements set out in Article 9.3.2. More specifically, the exclusion from the UTPR is effected by reducing to zero any amount of Top-up Tax that would otherwise be taken into account for determining the UTPR Top-up Tax Amount in accordance with Article 2.5.1.

16. Article 9.3.1 further provides that this exclusion applies notwithstanding the requirements otherwise provided in Chapter 5, such as the requirement to determine the ETR of a jurisdiction and compute the Top-up Tax due, if any. This means that there is no need for the MNE Group to compute the ETR of its Constituent Entities and no need to calculate the amount of Top-up Tax that would have been due if the exclusion did not apply.

17. The exclusion provided in Article 9.3.1 applies on an annual basis. Provided the conditions set in Article 9.3.2 are met for a Fiscal Year, the exclusion provided in Article 9.3.1 applies for that Fiscal Year.

Article 9.3.2

18. Article 9.3.2 provides two criteria for determining whether an MNE Group is in the initial phase of its international activity. Both of the criteria must be met for a given Fiscal Year in order for the MNE Group to qualify for the exclusion for that Fiscal Year.

19. Paragraph (a) provides that the exclusion in Article 9.3.1 only applies to MNE Groups that have Constituent Entities located in no more than six jurisdictions for a Fiscal Year. Thus, an MNE Group can qualify for the exclusion if it has Constituent Entities in up to five jurisdictions outside the Reference Jurisdiction (see Article 9.3.3 for the definition of the Reference Jurisdiction). For this purpose, there is no requirement that the five other jurisdictions are the same five jurisdictions over the five-year period during which the MNE Group can benefit from the exclusion. The location of a Constituent Entity is determined by applying the rules provided in Article 10.3. Stateless Constituent Entities are not located in any jurisdiction, so those entities are not counted for the purposes of determining the number of jurisdictions in which the MNE Group operates under these rules.

20. Paragraph (b) provides that the exclusion in Article 9.3.1 only applies to MNE Groups that have a limited amount of tangible assets outside the Reference Jurisdiction, i.e. the jurisdiction where they conduct the majority of their substantive activities when the MNE Group originally comes within the scope of the GloBE Rules. More specifically, paragraph (b) provides that MNE Groups qualify for the exclusion only if the sum of the Net Book Values of Tangible Assets of all Constituent Entities located in all jurisdictions other than the Reference Jurisdiction (defined under Article 9.3.3) does not exceed EUR 50 million for the Fiscal Year. As provided in Article 10.1, the Net Book Value of Tangible Assets means the average of the beginning and end of year values of Tangible Assets after taking into account accumulated depreciation, depletion, and impairment, as recorded in the financial statements. For purposes of Article 9.3.2(b), all Tangible Assets, as defined in Article 10.1 are taken into account, provided they are held by the Constituent Entities of the MNE Group that are located in the jurisdictions other than the Reference Jurisdiction over the relevant period. Article 9.3.2(b) provides that once the value of tangible assets held in jurisdictions other than the Reference Jurisdiction exceeds EUR 50 million, then the exclusion from the UTPR no longer applies. Tangible Assets of Stateless Constituent Entities are considered held by Constituent Entities located in a jurisdiction other than the Reference Jurisdiction for the purposes of assessing the EUR 50 million threshold, other than to the extent that the MNE Group demonstrates that those Tangible Assets are physically located in the Reference Jurisdiction.

21. For purposes of Article 9.3.2(b), Tangible Assets of Investment Entities that are not Excluded Entities are not taken into account because those entities are excluded from the application of the UTPR and the location of Investment Entities that are not Excluded Entities is not taken into account for purposes of determining the number of jurisdictions in which the MNE Group has Constituent Entities under Article 9.3.2(a). Tangible Assets held by a JV or its JV Subsidiaries are also not taken into account because those are not Constituent Entities for the purposes of Article 9.3 and are not required to apply the UTPR and the location of a JV and of its JV Subsidiaries is not taken into account for purposes of determining the number of jurisdictions in which the MNE Group has Constituent Entities. However, the Tangible Assets held by Minority-Owned Constituent Entities are taken into account for purposes of this rule and the location of Minority-Owned Constituent Entities is taken into account for purposes of determining the number of jurisdictions in which the MNE Group has Constituent Entities.

Article 9.3.3

22. Article 9.3.3 provides the definition for the Reference Jurisdiction for purposes of Article 9.3.2. The Reference Jurisdiction of an MNE Group is the jurisdiction where the MNE Group has the highest total value of Tangible Assets, where the total value of Tangible Assets in a jurisdiction is the sum of the Net Book Values of all Tangible Assets of all the Constituent Entities of the MNE Group that are located in that jurisdiction. For purposes of Article 9.3.3, all Tangible Assets, as defined in Article 10.1 are taken into account, provided they are held by the Constituent Entities of the MNE Group over the relevant period. As provided in Article 10.1, the Net Book Value of Tangible Assets means the average of the beginning and end values of Tangible Assets after taking into account accumulated depreciation, depletion, and impairment, as recorded in the financial statements.

23. For purposes of Article 9.3.3, the Reference Jurisdiction is identified in respect of the first Fiscal Year for which the MNE Group originally comes within the scope of the GloBE Rules and remains unchanged over the five-year period during which the MNE benefits from the exclusion.

Article 9.3.4

24. Article 9.3.4 provides that the exclusion in Article 9.3.1 only applies for a period of five years after the MNE Group has come within the scope of the GloBE Rules. MNE Groups are in scope of the GloBE Rules when they meet the requirements provided in Article 1.1. Therefore, the five year period runs from when the MNE Group first meets the requirements of Article 1.1 and includes the first Fiscal Year for which the MNE Group is subject to the GloBE Rules. Assume, for example, an MNE Group first meets the requirements provided in Article 1.1 for its Fiscal Year beginning 1 January 2025. That MNE Group does not benefit from the exclusion provided under Article 9.3.1 for any Fiscal Year that begins after 31 December 2029.

25. Article 9.3.4 further provides that for MNE Groups that are in scope of the GloBE Rules when they come into effect, the period of five years will start at the time the UTPR rules come into effect. Under this scenario the MNE Group will be in scope of the UTPR rules as from the first year when those rules come into effect. The legislative processes in different Inclusive Framework jurisdictions may progress at different rates such that some jurisdictions are able to legislate the GloBE Rules more expeditiously than others. Nevertheless, Inclusive Framework Members have agreed that the earliest the UTPR will come into effect in 2024. Accordingly, an MNE Group that meets the requirements provided in Article 1.1 for a Fiscal Year that begins before 1 January 2024 would not qualify for the exclusion provided under Article 9.3.1 in any Fiscal Year that begins after 31 December 2028. This is the case irrespective of whether any of the jurisdictions in which the Constituent Entities are located have adopted a UTPR that is effective as of the beginning of 2024.

26. In any case, the five-year period provided under Article 9.3.4 shall not be suspended by any circumstance. For instance, if the MNE Group meets the requirements provided in Article 1.1 for a Fiscal Year and its revenues decline in subsequent years such that and the MNE Group is not in scope of the GloBE Rules for any subsequent year, the five-year period continues to run.

Article 9.3.5

27. Article 9.3.5 contains an optional provision that allows the Reference Jurisdiction to use the UTPR to defend its tax base from a tax planning opportunity that may arise under the exclusion for MNEs in the initial phase of their international activity. Because the Article 9.3.1 exclusion treats all of the jurisdictions in which the MNE Group operates as having zero Top-up Tax, a largely domestic Group could establish a new UPE in a jurisdiction that does not have a Qualified IIR and then the Parent Entity could extract value from the domestic Group without being subject to minimum taxation under the UTPR. This gap in the coverage of the GloBE Rules could also provide a competitive advantage for UPEs located in a non-GloBE jurisdiction seeking to acquire MNE Groups.

28. To thwart this potential abuse of the Article 9.3.1 exclusion, jurisdictions that introduce a UTPR may consider providing an optional exception to Article 9.3.1 that would exclude the operation of Article 9.3 in that jurisdiction where it is the Reference Jurisdiction in respect of an MNE Group that is in the initial phase of its international activity. The reason for including such an option in Article 9.3 for those jurisdictions that choose to implement the GloBE Rules would be to provide a level playing field between locally-headquartered MNE Groups that are in the initial phase of their international activity (and would therefore be subject to the IIR in respect of their operations in Low-Tax Jurisdictions) and those MNE Groups in the initial phase of their international activity that maintain a UPE outside, but the major part of their operations within, that jurisdiction. An option for the Reference Jurisdiction to apply the UTPR to such Groups would help to limit the risk of locally-headquartered MNE Groups inverting out of the Reference Jurisdiction to escape the GloBE Rules.

29. Jurisdictions that wish to limit the operation of Article 9.3 in this way may consider adding an optional provision (Article 9.3.5) which provides that Article 9.3.1 shall not apply where the implementing Jurisdiction is the Reference Jurisdiction of the MNE Group. This will have the effect of preserving the ability of the Reference Jurisdiction to make an adjustment under the UTPR in respect of any amount of Top-up Tax that arises in a Low-Tax Jurisdiction. In order to allocate the full amount of Top-up Tax arising in those jurisdictions to the Reference Jurisdiction, Article 9.3.5(b) provides that the UTPR Percentage of the jurisdictions other than the Reference Jurisdiction is deemed to be zero.

30. Jurisdictions that implement Article 9.3.5 may also consider limiting the application of the UTPR under this paragraph to the Top-up Tax Amount that arises in Low-Tax Jurisdictions other than the Reference Jurisdiction. Article 9.3.5(a) achieves this by reducing the Top-up Tax Amount of a Low-Taxed Constituent Entity that would be taken into account under Article 2.5.1 to zero if that Low-Taxed Constituent Entity is located in the Reference Jurisdiction.

31. The option set out in Article 9.3.5 operates as an exception from the UTPR exclusion provided under Article 9.3 and therefore is subject to the general time limit provided in Article 9.3.4.

Article 9.4 - Transitional relief for filing obligations

32. Article 9.4.1 provides transitional relief for the filing and notification obligations pursuant to Article 8.1 with respect to the Transition Year. The filing and notification obligations must be fulfilled within 18 months, rather than the normal 15 months, after the end of the Reporting Fiscal Year that is the Transition Year.

10 Definitions

Article 10.1 - Defined Terms

1. Article 10.1 contains defined terms that are used in the GloBE Rules. The majority of these terms are discussed in the Commentary to the Articles that use those terms. The remaining defined terms are discussed here in the Commentary to Article 10.1.

2. The GloBE Rules and Commentary also use a number of common financial accounting terms, such as “profit and loss statement,” and phrases, such as “movement in an account” or “reversal of a liability”, that are not defined in Article 10.1. When financial accounting terminology or concepts that are not defined in Article 10.1 are used in the GloBE Rules or Commentary in connection with a GloBE Rule or principle that relies on financial accounting, such terms and concepts should be interpreted consistent with the meaning given to them in financial accounting standards and guidance. In addition, accounting terms used in the GloBE Rules or Commentary that equate to a different term used in another accounting standard are intended to incorporate or encompass the other term. For example, the terms “profit and loss statement” and “income statement” are used in different financial accounting standards to describe the same financial accounting statement. Thus, when the Commentary refers to a profit and loss statement, it is also referring to an income statement.

Authorised Financial Accounting Standard

3. The GloBE Rules lean heavily on the accounting principles applicable in the Consolidated Financial Statements. Consequently, the definition of Consolidated Financial Statements is central to defining the scope and operation of the GloBE Rules. In those cases where the UPE does not otherwise prepare financial statements on a consolidated basis or in accordance with an Acceptable Financial Accounting Standard, the GloBE Rules rely on the accounting principles that would apply if the UPE had prepared such statements in accordance with an Authorised Financial Accounting Standard.

4. Authorised Financial Accounting Standards are the accounting standards permitted by an Authorised Accounting Body, which is the body with legal authority in a jurisdiction to prescribe, establish, or accept accounting standards for financial reporting purposes in the jurisdiction in which the Constituent Entity is located. An Authorised Financial Accounting Standard may be one included in the list of Acceptable Financial Accounting Standard or it may be another locally permitted financial accounting standard. Where a locally-permitted financial accounting standard is not listed as an Acceptable Financial Accounting Standard, then the GloBE Rules require the outcomes under the local accounting standard to be compared with the expected outcomes under IFRS in order to evaluate whether there is a significant differences between the local standard and IFRS. In this case the treatment of items or transactions under the local accounting standard must be adjusted to neutralise the effect if any Material Competitive Distortions. The definition of Material Competitive Distortion is discussed further below in the Commentary to this Article. In any case, it is expected that a locally-permitted financial accounting standard that conforms to IFRS in all material respects will not produce any Material Competitive Distortions.

CFC Tax Regime

5. The rules in Article 4.3 generally allocate the Covered Taxes imposed on an item of income to the jurisdiction where the corresponding income arose. These rules include a specific rule in Article 4.3.2(c) for allocation of Covered Taxes arising under a CFC Tax Regime. The rule applies to Covered Taxes (CFC taxes) imposed on one Constituent Entity (the CFC shareholder) under a CFC Tax Regime in respect of income derived by another Constituent Entity (the CFC) located in a foreign jurisdiction. A jurisdiction that provides an exemption regime to PEs may apply its CFC Tax Regime to a PE located in another the jurisdiction in the same manner as if that PE was a foreign subsidiary.

6. CFC taxes imposed on a CFC shareholder are computed by reference to the shareholder's proportionate share of the income (or a specific item of income) derived by any CFC. CFC taxes are generally imposed on a current basis and may be imposed at the same or different rate as the CFC shareholder's regular tax rate. That is to say, the trigger for a tax liability under CFC Tax Regime is when the income is derived by the foreign subsidiary, not when it is distributed to a shareholder.

7. Although CFC Tax Regimes share some similarities with rules for the treatment of Tax Transparent Entities detailed in Article 10.2, CFC Tax Regimes generally apply to foreign corporate Entities, i.e. Entities that are not fiscally transparent under the laws of the jurisdiction where owner is located. Thus, absent the CFC Tax Regime, the shareholder generally would not be subject to tax in respect of the CFC's income (its attributable share) on a current basis, until the income is distributed. CFC Tax Regimes generally have special rules that restrict their operation to certain circumstances, such as when the shareholder or a group of domestic shareholders has a certain level of ownership, usually greater than 50%, in the foreign subsidiary

8. An IIR is not included in the definition of a CFC Tax Regime. Although CFC Tax Regimes impose tax on the owners of a foreign subsidiary, they are distinguishable from an IIR in that, the Top-up Tax under the IIR is initially computed on a jurisdictional basis so as to bring the tax paid on excess profits in that jurisdiction up to an agreed minimum tax rate. Those taxes are then allocated to each LTCE in proportion to that Entity's GloBE Income before being brought into charge by a Parent Entity. Given the policy and mechanical differences between the two, a jurisdiction is not required to replace an existing CFC Tax Regime by introducing an IIR and, therefore, is not prevented from employing both an IIR and a CFC Tax Regime in its domestic tax laws.

Disqualified Refundable Imputation Tax

9. The GloBE Rules exclude Disqualified Refundable Imputation Taxes from the definition of Covered Taxes. Disqualified Refundable Imputation Taxes are taxes, other than Qualified Imputation Taxes, that are initially imposed on the income of a Constituent Entity but when that income is distributed by way of dividend to the owners of the Constituent Entity, the Tax is refunded to the Constituent Entity or the owner or creditable against a tax liability of the owner other than a tax liability arising from the dividend. Disqualified Refundable Imputation Taxes are generally distinguishable from a Qualified Imputation Tax because they are not intended and, in practice, do not produce a single level of taxation. This is because the taxes are refunded without the dividend recipient being subject to tax on the distributed income. The final result of these tax regimes is that the income of the corporation is not subject to tax at all in the hands of the corporation or the shareholder. However, the definition also includes a tax that would meet the definition of a Qualified Imputation Tax except that the beneficial owners is subject to a nominal tax rate below the Minimum Rate on the distribution or to an individual who is not subject to tax on the dividends as ordinary income. Accordingly, Disqualified Refundable Imputation Taxes when accrued in the Constituent Entity's financial accounts or when paid to the relevant tax authority do not qualify as a Covered Tax and are not taken into account in computing the ETR of the jurisdiction in which the Constituent Entity is located. Similarly, the actual refund of a Disqualified Refundable Imputation Tax does not reduce Adjusted Covered Taxes.

10. The definition of Disqualified Refundable Imputation Tax extends only to the Taxes paid or accrued by the Constituent Entity in respect of its income that are refundable or creditable upon distribution of a dividend. Thus, if Tax paid in respect of certain types of income earned by the Constituent Entity¹ is not refundable upon distribution of a dividend, that amount of Tax is not a Disqualified Refundable Imputation Tax.

11. Taxes imposed on the dividend recipient and withheld by the distributing corporation on the payment of that dividend are not Disqualified Refundable Imputation Taxes, even if part or all of the withholding tax is ultimately refunded to the shareholder by the tax authority. These taxes are distinguishable from Disqualified Refundable Imputation Taxes because they are imposed on the shareholder when the dividend is distributed and reduce the net amount received by the shareholder. If the withheld tax is refunded to the shareholder, it is a refund of tax that was initially paid by the shareholder.

Eligible Distribution Tax System

12. The GloBE Rules contain an election in Article 7.3 with respect to Constituent Entities that are subject to an Eligible Distribution Tax System. Special rules are needed for these distribution tax systems because most of the tax imposed arises when corporate profits are actually distributed or deemed distributed and these distributions often occur after the year in which the related income is included in the computation of GloBE Income or Loss.

13. The term Eligible Distribution Tax system is used to describe the types of distribution tax systems that are eligible for special treatment under the GloBE Rules. An eligible distribution tax system is one that:

- a. imposes an income tax on the corporation with the tax generally payable only when the corporation distributes profits to shareholders, is deemed to distribute profits to shareholders, or incurs certain non-business expenses;
- b. imposes tax at a rate equal to or in excess of the Minimum Rate; and
- c. was in force on or before 1 July 2021.

14. An Eligible Distribution Tax System is a CIT that is imposed on the distributing corporation. It does not include taxes imposed on the shareholders in respect of distributions, even though these taxes may be withheld and remitted by the distributing corporation.

15. Distribution taxes are generally payable on a dividend or other distribution of profits from a corporation. However, the definition takes into account the fact that distribution tax systems may impose tax on actual or deemed distributions and on certain non-business expenses. This reflects the fact that these distribution tax systems typically include certain integrity measures to prevent taxpayers from enjoying the benefits of the profits of the corporation without incurring the charge to distribution tax. These measures may include the imposition of tax on certain deemed or hidden distributions. For example, certain loans granted to shareholders may be treated as a deemed or hidden distribution if the shareholder does not have the ability or intention to repay the loan. These deemed or hidden distributions are taxed in the same manner as actual distributions. There are also mechanisms designed to ensure that non-business expenses are subject to charge in the year the non-business expense arises.

16. To qualify as an Eligible Distribution Tax System, the system must impose tax at a rate that equals or exceeds the Minimum Rate. This requirement is intended to ensure that the deferral of tax permitted by the rule is not permitted with respect to income that would be low-taxed income in any case. This definition does not prevent an Eligible Distribution Tax System from having a graduated rate provided the rate that applies to MNE Groups within the scope of the GloBE Rules is at least equal to the Minimum Rate. Where a distribution tax jurisdiction applies tax at a nominal rate but requires that before applying the rate, the distributed amount has to be grossed up to reflect the gross tax basis before distribution tax, the statutory rate is the rate after the application of such gross up. To illustrate, assume that under a Distribution Tax

System the taxpayer is subject to tax on a distribution at a rate of 14% but on a distribution that is grossed up by a factor 1/0.86. A Constituent Entity distributes EUR 100 of income. The tax on that distribution would be EUR 16.28 (14% x [100/0.86]), which is 16.3% of 100 and therefore above the minimum rate.

17. The final requirement for an Eligible Distribution Tax System is that it has been continuously in force since on or before 1 July 2021. This is the date of the first Inclusive Framework Statement on the Digitalisation of the Economy that agreed the special treatment of Eligible Distribution Tax Systems. This requirement does not prevent changes to a jurisdiction's distribution tax system that are in line with its existing design.

Fiscal Year

18. Fiscal Year is defined as the accounting period used in the Consolidated Financial Statements (or, exceptionally in the case that such accounts are not prepared, the calendar year). Ordinarily, this period is a 12-month period or a period determined by reference to a specific day in a 12-month period, for example a 52-53 week Fiscal Year. However, it is possible that this period will not always be 12 months long and, in some cases, the GloBE Rules make specific provision to deal with long or short Fiscal Years, for example at Article 1.1.2. The Implementation Framework will further consider and provide guidance with respect to Fiscal Years that exceed 12 months, including instances in which a change in the Fiscal Year results in a transition year that exceeds 12 months.

Five-Year Election

19. This term is defined in Chapter 10 to mean an election made by a Filing Constituent Entity with respect to a Fiscal Year (the Election Year) that cannot be revoked with respect to the Election Year or the four succeeding Fiscal Years. A Five-Year Election remains in force indefinitely until a group actively revokes it. If a Five-Year Election is revoked with respect to a Fiscal Year (the revocation year), a new election cannot be made with respect to the four Fiscal Years succeeding the revocation year. Five-Year Elections are contained in Article 1.5.3, Article 3.2.2, Article 3.2.5, Article 3.2.8, Article 7.5.2, and Article 7.6.6.

20. The GloBE Implementation Framework will develop processes and provide guidance to facilitate the co-ordinated implementation of the GloBE Rules. This will include guidance to address the extent to which an election or revocation period continues when a Constituent Entity joins or leaves an MNE Group, including situations where an MNE Group subject to the GloBE Rules acquires Constituent Entities from another such MNE Group that made different choices in respect of Five-Year Elections in a particular jurisdiction, and necessary adjustments, if any, to the computation of GloBE Income or Loss.

GloBE Reorganisation

21. A GloBE Reorganisation is defined in Article 10.1. It is a broad definition that primarily refers to an acquisition or disposition where the sellers of the target entity are compensated with equity interests in the acquiring Entity or Group and the gains or losses on the acquired assets and liabilities are deferred under the local tax rules. Under local tax rules, gains or losses arising in connection with an asset reorganisation are generally deferred by requiring the acquiring Constituent Entity to take the transferor's carrying amounts of the acquired assets and liabilities. This mechanism preserves the built-in gain or loss on the assets and liabilities at the time of the reorganisation, which will be realised through the use of the assets in the production of income or upon sale. The GloBE Reorganisation definition relies on local tax rules that are based on these concepts.

22. Article 10.1 broadly defines the types of restructuring transactions that may qualify as a GloBE Reorganisation. The conditions in paragraphs (a) to (c) of the definition must also be met before a transaction qualifies as a GloBE Reorganisation. Thus, a transformation or transfer of assets and liabilities

such as in a merger, demerger, liquidation, or similar transaction may qualify as a GloBE Reorganisation. A transformation is a change in the form of an Entity, for example a change from a partnership to a corporation. The definition also includes, for example a contribution of assets to the capital of an existing Entity where the Entity does not issue new or additional Ownership Interests in exchange for the contributed property because the transaction does not result in a change in the relative ownership of the Entity and the issuance of additional Ownership Interest would be meaningless.

23. To qualify as a GloBE Reorganisation, the consideration for a transfer of assets and liabilities must be, in whole or in significant part, equity interests issued by the acquiring Constituent Entity or by a person connected with the acquiring Constituent Entity. A person should be treated as connected with the acquiring Constituent Entity for this purpose if it meets the test set out in Article 5(8) of the OECD Model Tax Convention (OECD, 2017^[1]). In the case of a liquidation, however, the consideration can be the cancellation of equity interests of the target. And as noted in the previous paragraph, in a capital contribution, no consideration is necessary where the issuance of an equity interest would have no economic significance. Finally, the definition of a GloBE Reorganisation does not impose any requirement with respect to whom the equity interests are issued. For instance, a transaction in which the equity interests are issued to the direct or indirect owner of the Entity whose assets and liabilities are acquired as part of the same arrangement could qualify as a GloBE Reorganisation.

24. The criteria to qualify as a GloBE Reorganisation in paragraphs (b) and (c) of the definition relate to the tax treatment of the transformation or transaction under local tax law. Under paragraph (b), the disposing Constituent Entity's gain or loss on the assets and liabilities must be partially or wholly non-taxable at the time of the transformation or transaction. The transformation or transaction does not need to be wholly non-taxable. The definition accepts that there may be some gain or loss that doesn't qualify for non-recognition treatment in the disposing Constituent Entity's jurisdiction. (This gain or loss will generally be Non-Qualifying Gain or Loss as defined in Article 10.1 and will result in a corresponding gain or loss under Article 6.3.3, explained in more detail in the Commentary to Article 6.3.3.)

25. Paragraph (c) contains the other non-recognition criteria. It stipulates that the tax laws of the jurisdiction in which the acquiring Constituent Entity is located must require the acquiring Constituent Entity to compute taxable income after the acquisition using the disposing Constituent Entity's tax basis in the assets and the same amount of liabilities, adjusted for any Non-Qualifying Gain or Loss on the disposition or acquisition. By preserving the disposing Constituent Entity's tax basis of assets and liability amounts, the local tax rules ensure that the gain or loss on the acquired assets and liabilities does not permanently escape taxation, but is only deferred. And to the extent that gain or loss is recognised, the local tax rules adjust the tax basis of assets and amounts of liabilities to ensure that such gain or loss is not again subject to tax in the future.

Governmental Entity

26. A Governmental Entity is one of the types of entity excluded from the scope of the GloBE Rules under Article 1.5 (an Excluded Entity). Governmental Entities are excluded from the charge to GloBE tax because they are sovereign entities that are not typically subject to tax in their own jurisdiction and often benefit from exclusions from taxation under foreign law or tax treaties. In order to be a Governmental Entity within Article 10.1 of the GloBE Rules the Entity must:

- a. be part of or wholly-owned by a government (including any political subdivision or local authority thereof);
- b. have the principal purpose of fulfilling a government function or managing or investing that government's or jurisdiction's assets and not carry on a trade or business;
- c. be accountable to the government on its overall performance, and provide annual information reporting to the government; and

- d. distribute any earnings to the government and vest its assets in the government upon dissolution.

27. Each of these criteria are discussed in further detail below.

Paragraph (a)

28. Paragraph (a) provides that such Entity must be part of the government or wholly-owned by a government (including any political subdivision or local authority thereof). The phrase “part of” means an Entity that is created under public law. The reference to “wholly-owned by a government” extends the application of paragraph (a) to corporations or other Entities created under private law provided that they are wholly-owned (directly or indirectly) by a government. The word “government” means General Government, which is defined in Article 10.1 as the central administration, agencies whose operations are under its effective control, state and local governments.

Paragraph (b)

29. Paragraph (b) sets limits on the type of activities an Entity can undertake in order to qualify as a Governmental Entity. It states that the principal purpose of the Entity must be: (i) fulfilling a government function; or (ii) managing or investing that government’s or jurisdiction’s assets through the making and holding of investments, asset management, and related investment activities for the government’s or jurisdiction’s assets.

30. The “government function” in sub-paragraph (i) is a broad term that is intended to include activities such as providing public health care and education or building public infrastructure or ensuring defence capability and law enforcement within the jurisdiction. The condition in sub-paragraph (ii) is intended to include Entities such as sovereign wealth funds (including those incorporated as companies) which governments typically use to hold and manage their investments. Sovereign wealth funds are commonly established out of balance of payments surpluses, official foreign currency operations, the proceeds of privatisations, fiscal surpluses or receipts resulting from commodity exports.¹ The function of a sovereign wealth fund is to invest these amounts for the purpose of managing a country’s future fiscal needs, stabilising a country’s balance of payments and in order to strike an appropriate balance between domestic consumption and savings.

31. Furthermore, paragraph (b) requires that the Entity does not conduct a trade or business. In the context of the GloBE Rules, this requirement was included to differentiate commercial enterprises owned by the government from entities whose activities are limited to those referred in subdivisions (i) and (ii). For instance, a sovereign wealth fund would be expected to meet the conditions set out in paragraph (b) because its activities would be limited to those referred in subdivision (ii) and it would not be carrying out commercial activities that could constitute a trade or business. Similarly, if the government (including a Governmental Entity) incorporates an Entity that meets all the other requirements in the definition and such Entity only provides products or services for use by that government to fulfil a governmental function, then the activities of the Entity are assimilated to a government function rather than a trade or business. On the other hand, a commercial bank owned by the government would not comply with paragraph (b) as it would be engaged in a trade or business.

Paragraph (c)

32. Paragraph (c) requires that the Entity is accountable to the government (including a Governmental Entity) on its overall performance, and provides annual information reporting to the government (including a Governmental Entity).

Paragraph (d)

33. Lastly, the condition under paragraph (d) requires that if the Entity distributes its net earnings that these are paid to the government (including a Governmental Entity) and upon dissolution of the Entity, its assets will vest in the government (including a Governmental Entity). In considering whether a distribution of earnings is made to a person other than government the facts and circumstances of the payment need to be taken into account. For example, a central bank that is organised as a company under public law issues part of its shares to private shareholders who are entitled to a fixed return based on their contributions. The central bank is controlled by the government and upon dissolution all of its assets are vested to the government and not the private shareholders. Under these specific facts and circumstances, the privately held shares are, in substance similar to a financing instrument that is assimilated to the return of long-term bonds rather than shares and therefore, the return is not considered a distribution of net earnings.

International Organisation

34. An International Organisation is one of the types of Entity excluded from the scope of the GloBE Rules under Article 1.5 (an Excluded Entity). The rationale for excluding International Organisations is similar to that for the exclusion for Governmental Entities.

35. The definition of International Organisation in Article 10.1 aligns with that used in the Standard for Automatic Exchange of Financial Account Information in Tax Matters. The language in paragraph (b) includes an explanation of a “substantially similar agreement” which is taken from the Commentary to that standard.

Investment Fund

36. The definition of Investment Fund draws on the definition of “investment entity” in IFRS 10 (IFRS Foundation, 2022^[2]) and the European Union Alternative Investment Fund Managers Directive 2011/61/EU (AIFMD) (European Union, 2011^[7]). To meet the definition of an Investment Fund, an Entity has to meet all of the following criteria:

- a. it is designed to pool assets (which may be financial and non-financial) from a number of investors (some of which are not connected);
- b. it invests in accordance with a defined investment policy;
- c. it allows investors to reduce transaction, research, and analytical costs, or to spread risk collectively;
- d. it is primarily designed to generate investment income or gains, or protection against a particular or general event or outcome;
- e. investors have a right to return from the assets of the fund or income earned on those assets, based on the contributions made by those investors;
- f. the Entity or its management is subject to a regulatory regime in the jurisdiction in which it is established or managed (including appropriate anti-money laundering and investor protection regulation); and
- g. it is managed by investment fund management professionals on behalf of the investors.

37. Each of these criteria is discussed in further detail below.

Paragraph (a)

38. Paragraph (a) requires the entity or arrangement to be designed to pool assets (financial and non-financial) from a number of investors (some of which are not connected). An investor could contribute cash or other kinds of liquid assets, or non-liquid assets such as immovable property to an Investment Fund.

39. Paragraph (a) requires that some of the investors of the fund be unconnected. A facts and circumstances test should be applied to determine whether two or more investors are connected. In any case, an investor should be treated as connected to another investor if it meets the test set out in Article 5(8) of the OECD Model Tax Convention (OECD, 2017^[1]). That test provides that two persons are connected if one possesses directly or indirectly more than 50% of the beneficial interest in the other (or in the case of a company, more than 50% of the aggregate vote and value of the company's share or the beneficial equity interest in the company) or if another person possesses directly or indirectly more than 50% of the beneficial interests in each person (or in the case of a company, more than 50% of the aggregate vote and value of the company's share or the beneficial equity interest in the company). Furthermore, two investors that are individuals are considered to be connected if they are part of the same family including a spouse or civil partner, siblings, parents, and ancestors and lineal descendants such as grandparents and grandchildren. In some instances, a fund will only have one investor for a short period of time, even though the fund is designed to pool assets for more than one unrelated investor. For example, a fund might have a single investor when the entity is within the initial offering period or in the process of liquidation. A fund in these circumstances with only one investor will meet the criteria of paragraph (a) provided that the fund was designed to pool assets from a number of investors (some of which are unconnected).

Paragraph (b)

40. Paragraph (b) requires an Investment Fund to have a defined investment policy and to invest according to that policy. Some factors that would, singly or cumulatively, tend to indicate the existence of such a policy are the following:

- a. the investment policy is determined and fixed, at the latest by the time that investors' commitments to the Investment Fund become binding on them;
- b. the investment policy is set out in a document which becomes part of or is referenced in the rules or instruments of incorporation of the Investment Fund;
- c. the Investment Fund or the legal person managing the Investment Fund has an obligation (however arising) to investors, which is legally enforceable by them, to follow the investment policy, including all changes to it; and
- d. the investment policy specifies investment guidelines, with reference to criteria including any or all of the following: (i) to invest in certain categories of assets, or conform to restrictions on asset allocation; (ii) to pursue certain strategies; (iii) to invest in particular geographical regions; (iv) to conform to restrictions on leverage; (v) to conform to minimum holding periods; or (vi) to conform to other restrictions designed to provide risk diversification.

Paragraph (c)

41. Paragraph (c) provides that the Investment Fund shall allow investors to reduce transaction, research and analytical costs, or to spread risk collectively. An Entity that is designed to undertake a particular function for members of an MNE Group (such as centralised financial or procurement services) could be described as reducing transaction costs or spreading risks. Nevertheless, such an Entity could not meet the wider definition of an Investment Fund.

Paragraph (d)

42. To qualify as an Investment Fund, the Entity must primarily be designed to generate investment income or gains, as opposed to operating income. The income generated through the fund has to be income that is derived from investment holdings such as dividends, interest, rent, returns from other Investment Funds and capital gains. Royalties are not included in this category. Alternatively, paragraph (d) permits that the fund is designed for the protection against a particular or general event or outcome. This wording is intended to cover situations where an Investment Fund is used by the insurance industry to cover insured events or outcomes.

Paragraph (e)

43. Paragraph (e) requires the investors to have a right to the return from the assets of the fund or income earned on those assets based on the contributions made by the investors. Investors may also earn capital gains from the disposal of Ownership Interests of the fund.

Paragraph (f)

44. The requirement under paragraph (f) is that the fund or the fund manager is subject to a regulatory regime in the jurisdiction in which it is established or managed (including appropriate anti-money laundering and investor protection regulation). This paragraph is intended to encompass the different approaches to prudential regulation of Investment Funds. In respect of an fund that is established or created by a government or that acts as an agent or mandatary of a government, to the extent that it does not qualify as a Governmental Entity, regulation may take any form endorsed by the General Government, for example provisions for accountability and review contained in the Investment Fund's constituting legislation.

Paragraph (g)

45. Finally, paragraph (g) requires the fund to be managed by professionals on behalf of the investors. The factors that would, singly or cumulatively, tend to indicate that the fund is managed by fund management professionals, include the following:

- a. The fund managers operate independently of the investors, and are not directly employed by the investors;
- b. The fund managers are subject to national regulation regarding knowledge and competence;
- c. Management compensation for services rendered is partly based on the performance of the fund.

Joint Venture

46. Joint ventures are not Constituent Entities of the MNE Group because under financial accounting standards their income, expenses, assets and liabilities are not consolidated with those of the rest of the MNE Group on a line-by-line basis. However, the low-taxed income of a joint venture, as defined for accounting purposes, will be brought within the scope of the GloBE Rules in accordance with Article 6.4, if it meets the following definition:

Joint Venture means an Entity whose financial results are reported under the equity method in the Consolidated Financial Statements of the UPE provided that the UPE holds directly or indirectly at least 50% of its Ownership Interests.

47. Under various acceptable and authorised accounting standards, the definition of a joint-venture includes Entities in which the joint-venturer has less than 50% of its Ownership Interests provided that the joint-venturer has joint control over the Entity. However, under the GloBE Rules, the JV definition only

includes those Entities in which the UPE holds directly or indirectly at least 50% of the Ownership Interests in the joint venture. For example, the definition in the GloBE Rules could apply to an equity investment held by a Constituent Entity in a joint venture where the terms of that investment entitle the investor to 50% or more of the profits, capital or reserves (the relevant test for GloBE purposes) but only 50% of the voting rights (the relevant test for financial accounting purposes).

48. The second sentence of the definition of JV sets a list of Entities that are excluded from the rules of Article 6.4. These exclusions are discussed in further detail below.

Paragraph (a)

49. Paragraph (a) excludes from the JV definition a UPE of a separate MNE Group that is subject to the GloBE Rules. This avoids treating a UPE of an MNE Group that is already subject to the GloBE Rules as a JV of another MNE Group and therefore, potentially subject to taxation under the GloBE Rules applied by two jurisdictions (once as a standalone MNE Group and another by virtue of Article 6.4 applicable to the second MNE Group).

Paragraph (b) to (d)

50. An Entity that would otherwise be treated as JV is excluded from the special rules in Article 6.4 if it meets the criteria of an Excluded Entity in accordance with Article 1.5. Paragraph (b) refers to the Entities described in Article 1.5.1, while paragraph (c) mirrors the extension to the Excluded Entity definition in Article 1.5.2.

51. Paragraph (c) requires that the Entity is held directly through an Excluded Entity referred in Article 1.5.1. This is the same requirement included in Article 1.5.2(a) and 1.5.2(b). The only difference is that those provisions include a “95% ownership test” and a “wholly or mainly owned test”. Making reference to such tests would make this paragraph inapplicable because the MNE Group would typically hold 50% of the Ownership Interests of the Entity to which this paragraph applies. This paragraph is then divided into three subparagraphs that replicate the requirements set out in Article 1.5.2.

52. Paragraph (d) confirms that an Entity that is held by an MNE Group composed exclusively by Excluded Entities is not a JV. This ensures that an MNE Group that would otherwise be excluded from the GloBE Rules because all of its Constituent Entities are Excluded Entities are not subject to the rules because they hold an interest in a JV.

Paragraph (e)

53. Paragraph (e) provides that a JV Subsidiary is not a JV. The distinction between JV and JV Subsidiary is used in the definition of JV Group.

JV Subsidiary

54. JV Subsidiary is referred to in the definition of a JV Group and in Article 6.4. This term is defined as an Entity whose assets, liabilities, income, expenses and cash flows are consolidated by a JV under an Acceptable Financial Accounting Standard (or would have been consolidated had it been required to consolidate such items in accordance with an Acceptable Financial Accounting Standard). This means that the JV and JV Subsidiary are part of the same Group (the JV Group).

55. The second sentence of the definition clarifies that a PE whose Main Entity is the JV or a JV Subsidiary shall be treated as a separate JV Subsidiary. Consequently, under this rule, subsidiaries and PEs are treated the same for purposes of Article 6.4.1, i.e. both are JV Subsidiaries. This parallels the treatment of both subsidiaries and PEs as Constituent Entities.

Main Entity

56. In the context of PEs, the term Main Entity was introduced in the GloBE Rules to refer to that part of an enterprise that would typically be referred to as the head office. The GloBE Rules avoid using the term “head office” however because that term does not have an agreed meaning and could lead to confusion, particularly in the context of Flow-through Entities. The mechanics of the GloBE Rules define the Main Entity as the Entity that includes in its financial statements the Financial Accounting Net Income or Loss that has been attributed to the PE in accordance with Article 3.4 (regardless of the person that is treated as the taxpayer subject to tax in the jurisdiction where the PE is located).

57. The definition of Main Entity is referred in several provisions in the GloBE Rules such as the definition of a Constituent Entity in Article 1.3 and in rules to allocate GloBE Income or Loss between a Main Entity and its PEs.

Material Competitive Distortion

58. The term Material Competitive Distortion is used in the GloBE Rules as part of the system for identifying the Authorised Financial Accounting Standard used in the preparation of Consolidated Financial Statements (which are, in turn, the starting point for computing the GloBE Income or Loss of Constituent Entities).

59. A specific rule is required to eliminate Material Competitive Distortions because the GloBE Rules permit the use of different accounting standards as the starting point for computing GloBE Income or Loss. The Inclusive Framework has not undertaken a comparison of differences between financial accounting standards that may be used in each Inclusive Framework jurisdiction. The Material Competitive Distortions limitation serves as a normalising rule to limit the benefit that MNE Groups might otherwise achieve from unique accounting principles and standards permitted under an Authorised Financial Accounting Standard that are not available under an agreed Acceptable Financial Accounting Standard.

60. Under the GloBE Rules, a Material Competitive Distortion exists when the application of a specific principle or procedure permitted by a financial accounting standard that is not an Acceptable Financial Accounting Standard results in an aggregate variation greater than EUR 75 million in a Fiscal Year as compared to the amount that would have been determined by applying the corresponding IFRS principle or procedure. The aggregate variation refers to the total variation reflected in the Consolidated Financial Statements of the MNE Group, and thus, takes into account the impact of the principle or procedure on all affected transactions of all Constituent Entities of the MNE Group. Where the application of a specific principle or procedure results in a material competitive distortion, the accounting treatment of any item or transaction subject to that principle or procedure must be adjusted to conform to the treatment required for the item or transaction under IFRS in accordance with any Agreed Administrative Guidance.

Net Book Value of Tangible Assets

61. The Net Book Value of Tangible Assets is used for two main purposes under the UTPR. First, the Net Book Value of Tangible Assets of a UTPR Jurisdiction is used to determine that jurisdiction’s UTPR percentage pursuant to Article 2.6. Second, the Net Book Value of Tangible Assets is used to assess whether an MNE is eligible for the exclusion from the UTPR under Article 9.3.

62. Under the definition set out in Article 10.1 of the GloBE Rules, the Net Book Value of Tangible Assets means:

“... the average of the beginning and end values of Tangible Assets after taking into account accumulated depreciation, depletion, and impairment, as recorded in the financial statements.”

63. And Tangible Assets means:

“... the tangible assets of all the Constituent Entities resident for tax purposes in the relevant tax jurisdiction. Tangible Assets do not include cash or cash equivalents, intangibles, or financial assets...”

64. The Net Book Value of Tangible Assets is computed on a jurisdictional basis for all Constituent Entities located in the jurisdiction. For this purpose, the definition in Article 10.1 provides that the Net Book Value is computed as the average value of the beginning and end of year values of Tangible Assets held by the Constituent Entities located in that jurisdiction for a given Fiscal Year. Using an average value addresses potential significant changes in the amount of Tangible Assets held at one point during the Fiscal Year at the jurisdictional level, e.g. because of the transfer of a Constituent Entity.

65. For example, assume an MNE Group that has only one Constituent Entity in a jurisdiction and that Constituent Entity holds a single Tangible Asset with a Net Book Value of 100 at the beginning of the Fiscal Year. Assume the Constituent Entity sells this asset during the year. The Net Book Value of that Constituent Entity's Tangible Assets at the end of Fiscal Year is zero. Therefore, the computation of the Net Book Value of Tangible Assets for that jurisdiction is equal to 50 $[(100+0)/2]$.

66. The Net Book Value of Tangible Assets is the sum of Net Book Values of all Tangible Assets held by Constituent Entities located in a given jurisdiction for a Fiscal Year, as well as Tangible Assets attributed to PEs. With regard to PEs, Tangible Assets are allocated to the tax jurisdiction in which the PE is located, provided those Tangible Assets are included in the separate financial accounts (or would have been included in the separate accounts) of that PE under the same principles as determined by Article 3.4.1 and adjusted in accordance with Article 3.4.2.

67. Although the Net Book Value of Tangible Assets takes into account depreciation and other cost recovery allowances, Tangible Assets also include tangible assets that are not subject to depreciation or other cost recovery allowance methods.

68. For purposes of determining the Net Book Value of Tangible Assets, the term “Tangible Assets” is in line with that provided in the report on BEPS Action 13 for purposes of CbCR and is not restricted to the “Eligible Tangible Assets” defined for purposes of Article 5.3.4. For example, the term “Tangible Assets” would include property (including land or buildings) held for investment, sale, or lease as well as Tangible Assets used in the generation of a Constituent Entity's International Shipping Income and Qualified Ancillary International Shipping Income (i.e. ships, other maritime equipment and infrastructure), even though those assets are not Eligible Tangible Assets for purposes of Article 5.3.4. In addition, unlike what is required for the Eligible Tangible Assets referred to in Article 5.3.4 for purposes of the computation of the Substance-based Income Exclusion, there is no requirement that the Tangible Assets are located in the jurisdiction of the Constituent Entity for purposes of determining the Net Book Value of Tangible Assets.

Non-profit Organisation

69. A Non-profit Organisation is one of the categories of Excluded Entities under Article 1.5.1. The definition of Non-profit Organisation is based on paragraph h) of the definition of “Active Non-Financial Entity (NFE)” included in Section VIII (Defined Terms) in the Standard for Automatic Exchange of Financial Account Information in Tax Matters.

70. Paragraphs (a) of the definition sets out the general purposive criteria of the Non-Profit Organisation definition. A Non-Profit Organisation is an Entity established and operated in its jurisdiction of residence exclusively for religious, charitable, scientific, artistic, cultural, athletic, educational, or other similar purposes such as public health, the advancement and protection of human rights or animal rights, or environmental protection. It also includes a professional organisation, business league, chamber of commerce, labour organisation, agricultural or horticultural organisation, civic league or an organisation operated exclusively for the promotion of social welfare or other similar purposes. A Non-Profit Organisation is resident in the jurisdiction in which it is created and managed.

71. Paragraphs (b) and (c) require that substantially all of the Entity's income is tax-exempt for local tax purposes and that the Entity has no shareholders or members with a beneficial interest in its income or assets.

72. Paragraph (d) of the definition sets the principle that the income or assets of the Entity may not be distributed or applied for the benefit of a private person or a non-charitable Entity. It then states three exceptions.

- a. The first one included in subparagraph (i) is where the distribution or benefit is pursuant to the conduct of the Entity's charitable activities. For instance, where an Alumni foundation of a university is funding the education expenses of students that need aid.
- b. The second exception is where there is a payment of reasonable compensation for services rendered or for the use of property or capital. For instance, where an Entity (lessee) makes rental payments to a private person (lessor) for the right to use office space or other premises needed for its operation.
- c. The third exception covers the situation in which the Entity makes a payment to private person representing the fair market value of property which the entity has purchased. For example, where an organisation buys immovable property from a private person at fair market value to establish its offices.

73. Paragraph (e) of the definition ensures that if the Entity disappears its assets are transferred to another Non-profit Organisation or to the Government (including a Governmental Entity). It states that upon termination, liquidation or dissolution of the Entity, all of its assets must be distributed or revert to a Non-profit Organisation or to the government (including any Governmental Entity) of the Entity's jurisdiction of residence or any political subdivision thereof.

74. The analysis to be made under paragraph (e) has to take into account, for example, the articles of incorporation of the Entity or any other arrangement, as well as the applicable provisions and guidance under domestic law, that determines the persons or Entities that have the rights of the assets when it is terminated, liquidated or dissolved.

75. The last part of the definition of Non-profit Organisation includes a general condition that disqualifies any Entity that carries on a trade or business that is not directly related to the purposes for which it was established. For example, an Entity that sells shirts or other products with its logo as part of its activities to raise funds for the organisation would not be disqualified by this condition because such business is related to the purposes for which it was established. On the other hand, an Entity that is exclusively dedicated on selling products would not qualify under this condition even if it gives up its profits to a good cause. An Entity that meets the definition of a Non-Profit Organisation may be the UPE of an MNE Group. However, an Entity that simply serves as the holding company for an internationally operating commercial business will not qualify as a Non-profit Organisation merely because it is classified as a non-profit foundation or similar under local tax rules.

Number of Employees

76. The Number of Employees is used for purposes of determining a UTPR jurisdiction's UTPR percentage pursuant to Article 2.6.

77. Under the definition set out in Article 10.1 of the GloBE Rules, the Number of Employee means:

“...the total number of employees on a full-time equivalent (FTE) basis of all the Constituent Entities resident for tax purposes in the relevant tax jurisdiction. For this purpose, independent contractors participating in the ordinary operating activities of the Constituent Entity are reported as employees...”

78. The definition used for the Number of Employees is in line with that provided in the report on BEPS Action 13 for purposes of CbCR. The Number of Employees is computed as the total number of employees on a full-time equivalent basis and may be reported as of the year-end, on the basis of average employment levels for the year, or on any other basis consistently applied across tax jurisdictions and from year to year, provided that such basis allows to assess the total number of employees on a full-time equivalent basis for the relevant Fiscal Year. Using a full time equivalent basis addresses the fact that employees may be employed by several Constituent Entities or may be shared between a Main Entity and its PE. It also addresses potential significant changes in the scope of employees at the jurisdictional level, e.g. because of the transfer of a Constituent Entity. In addition, reasonable rounding or approximation of the number of employees is permissible, providing that such rounding or approximation does not materially distort the relative distribution of employees across the various tax jurisdictions. Consistent approaches should be applied from year to year and across entities. More details will be provided in connection with the guidance on filing obligations developed as part of the GloBE Implementation Framework.

79. The Number of Employees refers to all employees, including independent contractors participating in the ordinary operating activities of the Constituent Entities, like the definition of Eligible Employees provided under the GloBE Rules. Unlike BEPS Action 13, which provides that those independent contractors may be reported as employees for purposes of CbCR, the definition used for Number of Employees always takes these independent contractors into account when they participate in the ordinary operating activities of the Constituent Entity. This is because independent contractors that participate in the ordinary operating activities of the Constituent Entity make as much of a contribution to substance as employees and are therefore counted as such for purposes of determining a jurisdiction's UTPR Percentage. For instance, an independent contractor that is hired by a Constituent Entity to replace an employee during a leave of absence due to illness participates in the ordinary operating activities of that Constituent Entity. The Filing Constituent Entity bears the burden of demonstrating the extent to which independent contractors participate in the ordinary operating activities of a Constituent Entity. The Number of Employees is computed on a jurisdictional basis for all Constituent Entities located in a given jurisdiction and also includes employees attributed to PEs. The Number of Employees to be reported in the jurisdiction in which the PE is situated is the number of employees for which the payroll costs are included in the separate financial accounts (or that would have been included in the separate accounts) of that PE under the same principles as determined by Article 3.4.1 and adjusted in accordance with 3.4.2. This requirement is in line with the approach taken for purposes of the payroll carve-out under the Substance-based Income Exclusion.

80. The employees are allocated to the jurisdictions where the Constituent Entities or the PEs that bear the relevant salary expense are located, without any consideration of the location where the employees perform their activity. Unlike what is required for the Eligible Employees referred to in Article 5.3.3 for purposes of the computation of the Substance-based Income Exclusion, there is no requirement that the employees of a Constituent Entity (including a PE) perform activities for the MNE Group in the jurisdiction of the Constituent Entity for purposes of determining the Number of Employees taken into account to compute the UTPR Percentage of that jurisdiction. Similarly, the activities that those employees perform are not relevant for purposes of determining to which Constituent Entity the Number of Employees shall be allocated. In particular, an employee that is employed by a Constituent Entity that renders services to another Constituent Entity is counted as an employee of the former Constituent Entity.

Ownership Interest

81. The term Ownership Interest is used throughout the GloBE Rules. It is relevant for determining membership in a Group and MNE Group and a Parent Entity's Allocable Share of an LTCE's Top-up Tax, among other things. It means any equity interest that carries rights to the profits, capital or reserves of an Entity. It also refers to the interest that a Main Entity has in the profits, capital or reserves of its Permanent Establishment(s). The term Ownership Interest includes an equity interest in a Flow-Through Entity, such

as a partnership or trust, that carries rights to the profits, capital or reserves of the Flow-Through Entity or a PE of the Flow-Through Entity. Note that an equity interest only needs to hold a right to any one of profits, capital or reserves; thus, for example, an equity interest which only carries rights to capital and no other rights is still an equity interest for the purposes of the GloBE Rules. Ownership Interests often carry voting rights, but some Ownership Interests may not carry voting rights.

82. Ownership Interests may carry rights to profits and capital or reserves in different percentages. For example, an Ownership Interest may carry a right to 20% of the profits of an Entity but only 10% of the capital of the Entity. In places, the GloBE Rules specify the particular right of the Ownership Interest that is relevant for determining the applicability of a certain rule, e.g., the definition of a POPE.

83. Where the Model Rules do not discuss a specific right, such as in the definitions of JV, MOPE and Stapled Structure, then equal regard should be given to each class of relevant economic right (i.e. profits, capital or reserves). This is because, without a specified right, all have equal importance. For example, assume Entity A issues Ownership Interests of two types, profit units which carry equal rights to the profits of the entity and capital units which carry equal rights to the capital of the entity in liquidation. These units are held by 3 other entities, B, C and D. Entity B holds 50% of the issued Profit Units and 80% of the issued capital units. Entity C holds 50% of the profit units. Entity D holds the remaining 20% of capital units. Entity B's Ownership Interest amounts to the average of its Ownership Interests in Entity A, $(\frac{1}{2} \times 50\%) + (\frac{1}{2} \times 80\%) = 65\%$. Entity C has 25% of the Ownership Interest in A, $(\frac{1}{2} \times 50\%) + (\frac{1}{2} \times 0)$. Entity D has the remaining 10% $(\frac{1}{2} \times 0) + (\frac{1}{2} \times 20\%)$.

84. However, under Article 3.5.1(b), Financial Accounting Net Income or Loss is allocated to Constituent Entity-owners in accordance with their Ownership Interests and in this case it is appropriate to only consider the rights to profits carried by their Ownership Interests. This is because 3.5.1(b) is specifically concerned with the allocation of Financial Accounting Net Income, which makes rights to profit the natural metric.

85. The definition uses the term equity interest to distinguish between an Ownership Interest and other rights to the profits, capital, or reserves of an Entity, such as profit-sharing agreements with employees that do not carry any equity rights to the Entity or creditors rights to compel sale certain assets to satisfy an obligation of the Entity that is in default. An equity interest is an interest that is accounted for as equity under the financial accounting standard used in the preparation of the Consolidated Financial Statements. Similarly, whether a Constituent Entity is the owner of an equity interest, e.g. shares of stock that have been loaned to another person in connection with a short sale or stock sold with a repurchase obligation, is determined based on the accounting treatment of the interest in the Consolidated Financial Statements.

Passive Income

86. The definition of Passive Income is used in the limitation of the push down of taxes under Article 4.3.3. The term Passive Income is defined in Chapter 10 to mean income that is: (a) a dividend or dividend equivalents; (b) interest or interest equivalent; (c) rent; (d) royalty; (e) annuity (i.e., a contractual entitlement to payments over a period of time); or (f) net gains from property of a type that produces income described in (a) to (e). Items of Passive Income are only subject to a limitation on the pushdown of taxes to the extent a Constituent Entity-owner is subject to tax on such income under a CFC Tax Regime or as a result of an Ownership Interest in a Hybrid Entity.

87. The list of Passive Income items is intended to be a bright-line test that focuses on mobile payments with a readily identifiable character. This definition of Passive Income does not include any test of whether an item of income is earned as part of an active business. An active business test has been left out of the definition of Passive Income in order to avoid the need to make qualitative judgments which could possibly lead to inconsistencies in the application of the ETR calculations. The definition of Passive Income agreed by the Inclusive Framework for the purposes of the GloBE Rules is therefore a special

purpose definition and should not be interpreted as expressing a view on the appropriate scope of income that should be subject to charge under a CFC rule. This definition of Passive Income, while broad, is appropriate in the context of the GloBE Rules since it is being used to constrain the blending effect of taxes paid in respect of a CFC or hybrid entity. This is not a definition which would necessarily be considered appropriate in any other circumstances.

Pension Fund

88. A Pension Fund is an Excluded Entity in accordance with Article 1.5.1. Under paragraph (a), Pension Fund means an Entity that is established and operated exclusively or almost exclusively to administer or provide retirement benefits and ancillary and incidental benefits to individuals.

89. Paragraph (a)(i) of the definition of Pension Fund is in line with the definition of “recognised pension fund” included in Article 3, paragraph 1 i) (i) of the OECD Model Tax Convention and the Commentary on this Article 3(1) i) (i) is also relevant to this definition subject to the differences between the GloBE Rules and tax treaties (OECD, 2017^[11]). The definition differs from that used in the Model Tax Convention because it has been modified to remove reference to the fund being taxable as a separate person in the jurisdiction of formation, to allow for Pension Funds formed in a different legal arrangement such as a trust. The definition applies to both public and private Pension Funds.

90. Paragraph (a)(ii) of the definition extends the definition of Pension Fund to include a fund that is not regulated, as such, but is held by a trust or other fiduciary arrangement in order to meet pension obligations that are secured or otherwise protected by national regulation. This extended definition is intended to cover any situation where an Entity is not subject to regulation as a pension fund but is established to administer or provide retirement benefits, and those benefits are secured or otherwise protected by national regulations and funded by a pool of assets held through a fiduciary arrangement or trustor to secure the fulfilment of the corresponding pension obligations. For example, this covers self-administered pension funds where the MNE administers the funds for the benefit of its employees where these benefits are themselves secured through national regulation.

91. Paragraph (b) states that a Pension Fund includes a Pension Services Entity. The definition of a Pension Services Entity is described in further detail below.

Pension Services Entity

92. The term Pension Services Entity is used in the definition of Pension Fund. It is also referred in Article 1.5.2 because it excludes Entities owned by Pension Services Entities from being Excluded Entities under Article 1.5.2.

93. This definition covers two types of Entities. The first type is described in paragraph (a), which refers to an Entity established to operate exclusively or almost exclusively to invest funds for the benefit of a Pension Fund. The second type of Pension Services Entity is one that is established and operated exclusively or almost exclusively to carry out activities that are ancillary to the regulated activities that are carried out by the Pension Fund (referred in paragraph (a) of the definition).

94. Paragraph (b) does not require the Entity to provide services directly to a Pension Fund as defined by paragraph (a) of the definition of Pension Fund. It only requires that its activities are ancillary to the regulated activities carried out by such Pension Fund and that the Entity and the Pension Fund are members of the same Group as defined by Articles 1.2.2 and 1.2.3. For example, a Pension Fund that meets the requirements of paragraph (a) of the definition of Pension Fund incorporates an Entity (A Co) to serve as its fund manager. A Co, which is responsible for the Pension Fund’s overall investing strategy, incorporates another Entity located in jurisdiction B (B Co), which provides advisory services to A Co on investment opportunities in jurisdiction B. All of the Entities involved are members of the same group. In

this case, B Co is a Pension Services Entity notwithstanding that it is not providing services directly to the Pension Fund because its activities are ancillary to those of the Pension Fund.

95. The phrase “exclusively or almost exclusively” denote a facts and circumstances test that requires that all or almost all of the activities of the Entity have to be the ones referred in paragraphs (a) or (b). This phrase draws on the language used in the definition of a “recognized pension fund” in Article 3 of the OECD Model Tax Convention and its Commentary referring to such phrase (see paragraph 10.11 on the Commentary on Article 3), and its interpretation has to take into account the differences in purpose between the GloBE Rules and tax treaties (OECD, 2017^[11]).

Permanent Establishment

96. The term Permanent Establishment is referred in several provisions in the GloBE Rules, including in the definition of a Constituent Entity in Article 1.3. This definition only applies for purposes of the GloBE Rules and is not intended to affect the interpretation of this term in tax treaties or domestic law or the definition of a PE for the purposes of CbCR. The definition of PE is divided into four scenarios. A PE exists for purposes of the GloBE Rules if one of these four situations arises.

Paragraph (a)

97. Paragraph (a) refers to the situation where there is a Tax Treaty in force. In this case, the GloBE Rules acknowledge the existence of a PE in accordance with the Tax Treaty provided that the source country taxes in accordance with a provision similar to Article 7 of the OECD Model Tax Convention. Paragraph (a) defines a PE as including:

“a place of business (including a deemed place of business) situated in a jurisdiction and treated as a PE in accordance with an applicable Tax Treaty in force provided that such jurisdiction taxes the income attributable to it in accordance with a provision similar to Article 7 of the OECD Model Tax Convention on Income and on Capital.”

98. Paragraph (a) starts by referring to a place of business or a deemed place of business. The phrase “deemed place of business” was included for situations in which the non-resident does not have a place of business but its activities in the source jurisdiction are deemed to be a PE under the terms of the Treaty, for example a dependent agent PE.

99. A PE only exists in accordance with paragraph (a) if it exists for purposes of the Tax Treaty. Determinations by domestic courts and competent authorities are taken into account in this context. For example, paragraph (a) is met if the competent authorities of the jurisdictions involved have agreed through a mutual agreement procedure (MAP) that a PE exists in accordance with the Tax Treaty. Similarly, final rulings of domestic courts or administrative tribunals regarding the existence of a PE in accordance with a Tax Treaty are taken into account for purposes of paragraph (a).

100. The phrase “applicable Tax Treaty in force” refers to the case where a Tax Treaty has entered into force and its provisions have come into effect with respect of the tax in question. For instance, if a Tax Treaty enters into force in year 1 and comes into effect in year 2, then paragraph (a) would not apply for year 1.

101. Paragraph (a) also requires that the source jurisdiction taxes the income attributable to the PE in accordance with a provision similar to Article 7 of the OECD Model Tax Convention. For example, a Constituent Entity resident in Country R is dedicated to the operation of aircraft in international traffic and has an office in Country S through which it carries on part of its business. Assume that the R-S treaty follows the OECD Model Tax Convention. In accordance with Article 5 of the treaty, this Constituent Entity has a PE in Country S. However, by virtue of Article 7(4) and Article 8 of the treaty, Country S is not able

to tax the profits of the PE. In that case, a PE does not exist for purposes of the GloBE Rules in accordance with paragraph (a) regardless that it meets the definition of a PE of the treaty.

102. The phrase “a provision similar to Article 7 of the OECD Model Tax Convention” ensures that the source country taxes the income as income attributable to a PE without requiring the relevant provisions of the Tax Treaty to replicate the language or outcomes Article 7 of the 2017 OECD Model Tax Convention. For instance, the Tax Treaty could include Article 7 of the OECD Model Tax Convention as it read before July 22, 2010 or the one included in 2017 UN Model Double Taxation Convention between Developed and Developing Countries.

Paragraph (b)

103. Paragraph (b) refers to the taxation of income attributable to a PE or a similar concept (e.g. US trade or business) in accordance with domestic law in cases where there is no Tax Treaty in force between the residence and source jurisdictions. Stated differently, it refers to the case where jurisdictions have adopted a definition and taxation rules for a PE (or a similar concept) into their domestic law and no Tax Treaty applies. In these situations, the GloBE Rules recognize their existence and treatment under domestic law, and therefore, considers them as PEs.

104. For example, A Co and B Co are Constituent Entities resident in Country A and B respectively, and the sole partners of a partnership organized in Country C. Under the domestic law of Country C, the partnership is considered as tax transparent, and A Co and B Co are treated each as having a PE in Country C. In this case, the GloBE Rules follow the domestic law of Country C by recognizing the existence of the two PEs as two separate Constituent Entities.

105. Paragraph (b) applies where there is no applicable Tax Treaty, it defines a PE as including:

“a place of business (including a deemed place of business) in respect of which a jurisdiction taxes under its domestic law the income attributable to such place of business on a net basis similar to the manner in which it taxes its own tax residents;”

106. As for paragraph (a) the paragraph (b) starts by referring to a “place of business (or a deemed place of business)”. Whether a place of business or deemed place of business exists under this paragraph is a matter of domestic law. It is irrelevant if the domestic law uses this terminology in their own definitions. However, a place of business needs to exist in the source jurisdiction to meet with this part of the sentence through which activities takes place. In the case of a “deemed place of business” a connection needs to be established in domestic law between the source jurisdiction and the activities taking place in such jurisdiction.

107. Paragraph (b) further requires that the source jurisdiction taxes the income attributable to a “domestic PE” on a net basis similar to the manner in which it taxes its own tax residents. It does not require that the “domestic PE” is taxed exactly the same as a tax resident, as long as it is taxed in a similar manner. For instance, a “domestic PE” would be taxed in a similar manner as a tax resident in the source jurisdiction regardless that the deductibility of its expenses are subject to further limitations not applicable to resident taxpayers. Furthermore, the taxable income has to be attributable to the “domestic PE”, which means that activities have to be carried out through it in the source jurisdiction. Finally, this condition excludes from paragraph (b) any source taxation based on a gross basis (e.g. a withholding tax).

Paragraph (c)

108. Paragraph (c) applies only where a jurisdiction has no CIT system, it defines a PE as including:

“a place of business (including a deemed place of business) situated in that jurisdiction that would be treated as a PE in accordance with the OECD Model Tax Convention on Income and on Capital provided that such

jurisdiction would have had the right to tax the income attributable to it in accordance with Article 7 of that model.”

109. A PE exists for purposes of paragraph (c) if there is a place of business or a deemed place of business in such jurisdiction that would be treated as a PE in accordance with the OECD Model Tax Convention provided that such jurisdiction would have the right to tax the income attributable to it in accordance with Article 7 of that model.

110. This Paragraph requires a hypothetical analysis of whether a PE would have existed in the jurisdiction with no CIT system (referred in this paragraph as the “source country”). The analysis proceeds as if the residence and source country had a treaty that replicates the last version of the OECD Model Tax Convention. This means that it takes into account the version of the OECD Model Tax Convention of the year in which this analysis is made. For example, a Constituent Entity located in Country A does not have a PE in the source country during the years 1 to 4 in accordance with the OECD Model Tax Convention. In year 5, the model is modified in a way that creates a PE in the source country. In this case, paragraph (c) is met in year 5.

Paragraph (d)

111. Paragraph (d) creates a PE for purposes of the GloBE Rules in situations where the jurisdiction in which a Constituent Entity is located exempts the income attributable to the operations conducted outside such jurisdiction. Paragraph (d) applies only where the PE does not fall within the previous paragraphs (a) to (c) and defines a PE as including: a place of business (or a deemed place of business) “through which operations are conducted outside the jurisdiction where the Entity is located provided that such jurisdiction exempts the income attributable to such operations.”

112. By excluding PEs already described in paragraphs (a) to (c), the definition avoids any overlap between PEs falling under this paragraph and the other types of PE listed in the paragraph above. Drawing a clear dividing line between stateless PEs under paragraph (d) and those under paragraphs (a) – (c) is important for determining the location of the PE in accordance with Article 10.2. For example, A Co is located in jurisdiction A and conducts activities in jurisdiction B through a person that habitually concludes contracts in the name of A Co. Jurisdiction B has adopted the definition of a PE of Article 5 of the OECD Model Tax Convention into its domestic law and taxes the income attributable to it. Jurisdiction A exempts the income earned by A Co through the PE. Jurisdictions A and B do not have a Tax Treaty. In this case, paragraph (b) is triggered because jurisdiction B taxes the income attributable to a PE in accordance with its domestic law. Paragraph (d) is also triggered because jurisdiction A exempts the income attributable to the operations carried out through the PE. In this case, a PE exists in jurisdiction B for purposes of the GloBE Rules. If, however, jurisdiction B does not treat an agent that habitually concludes contracts in the name its principal as giving rise to a PE under local law then paragraph (d) would apply, but the PE would be stateless for the purposes of the GloBE Rules, meaning that the income of the PE would be subject to the GloBE Rules on a standalone basis without the ability to blend its income with other Constituent Entities located in jurisdiction B.

113. The first part of the definition refers to “a place of business (or a deemed place of business)”. It is irrelevant if the jurisdiction where the Constituent Entity (e.g., Main Entity) is located considers the existence of a place of business (or deemed place of business) in another jurisdiction or if one exists in accordance with domestic law of a source jurisdiction or tax treaties. The requirement under paragraph (d) is that such jurisdiction is exempting the income generated through foreign operations.

114. Paragraph (d) refers to a place of business (or a deemed place of business) through which operations are conducted outside the jurisdiction where the entity is located where the income attributable to those operations is exempt from tax. This language is intended to ensure that this paragraph only applies where exemption is attributable to the fact that the operations are treated as conducted by the Constituent Entity outside the jurisdiction. For example, if a shareholder of a foreign subsidiary benefits from a foreign

dividend exemption (e.g., participation exemption), paragraph (d) would not be triggered because the income is not exempted on the grounds that the shareholder is carrying out operations in the other jurisdictions related to the dividend.

Qualified Domestic Minimum Top-up Tax

115. In applying the GloBE Rules in the implementing jurisdiction, both taxpayers and tax administrations may need to evaluate whether Constituent Entities in that same group are subject to a Qualified Domestic Minimum Top-up Tax in another jurisdiction in order to correctly apply GloBE Rules. Most domestic income Taxes are Covered Taxes taken into account in the ETR computation and indirectly reduce the amount of Top-up Tax computed under Article 5.2. Under Article 5.2, however, tax arising under a Qualified Domestic Minimum Top-up Tax directly reduces the amount of Top-up Tax arising under the GloBE Rules. For example, a Parent Entity with an Ownership Interest in what would otherwise be a LTCE generally will not have any liability under the IIR if that Constituent Entity is subject to a Qualified Domestic Minimum Top-up Tax that imposes the same amount of tax that would otherwise arise under the IIR.

116. Qualified Domestic Minimum Top-up Tax means a tax that applies to Excess Profits of the domestic Constituent Entities and operates to increase domestic tax liability with respect to those profits to the Minimum Rate. The tax must be implemented and administered in a way that is consistent with the outcomes provided for under the GloBE Rules and their Commentary, including the prohibition against the implementing jurisdiction providing any collateral or other benefits that are related to such domestic tax as discussed further in the Commentary to the definition of a Qualified IIR. This limitation on collateral benefits is not intended to restrict the ability of a jurisdiction to make changes to the design of its corporate tax system in light of the new international tax architecture under the GloBE Rules. Such changes to the domestic corporate tax rules consequent on the introduction of a domestic minimum tax should not be considered a benefit provided that they do not result in MNE Groups achieving overall tax outcomes that are inconsistent with the outcomes provided for under the GloBE Rules and their Commentary.

117. The fact that the minimum tax is computed based on a local Authorised Financial Accounting Standard that is different from the standard used in the Consolidated Financial Statements does not prevent the tax from being treated as a Qualified Domestic Minimum Top-up Tax, provided that the locally authorised accounting standard is either an Acceptable Financial Accounting Standard or has been adjusted to the standard used by the MNE Group in respect of any Material Competitive Distortions.

118. The GloBE Implementation Framework will develop processes and provide guidance to facilitate the co-ordinated implementation of the GloBE Rules. This will include implementing a process to assist tax administrations in determining whether a minimum tax is considered as a Qualified Domestic Minimum Top-up Tax. In order to facilitate compliance by MNEs and administration by tax authorities, the outcome of these determination would be released and made publicly available.

Qualified IIR

119. The definition of Qualified IIR is relevant for purposes of applying the IIR in Articles 2.1 to 2.3. In applying the GloBE Rules in the implementing jurisdiction, both taxpayers and tax administrations often need to evaluate whether other Constituent Entities in that same group are subject to a Qualified IIR in another jurisdiction in order to correctly apply GloBE Rules. For example, a taxpayer that is an Intermediate Parent Entity will not be required to apply the IIR in respect of its Ownership Interest in any LTCE if the UPE of the MNE Group is required to apply a Qualified IIR in the same Fiscal Year.

120. The definition of Qualified IIR refers to “a set of rules equivalent to Article 2.1 to 2.3 of the GloBE Rules (including any provisions of the GloBE Rules associated with those articles) that are included in the domestic law of a jurisdiction and that are implemented and administered in a way that is consistent with the outcomes provided for under the GloBE Rules and their Commentary”. The intention of this phrase is

to ensure that the IIR adopted in the domestic law of a jurisdiction is both implemented and applied in a way that produces the same outcomes as the ones described in the GloBE Rules and their Commentary. This includes administrative provisions of the GloBE Rules and timely collection of tax arising thereunder.

121. The definition does not require a comparison between the domestic laws of one jurisdiction and another, rather it compares the rules legislated in a jurisdiction with the relevant provisions of the GloBE Rules and their Commentary as developed by the OECD/G20 Inclusive Framework on Base Erosion and Profit Shifting. This ensures that the IIRs of each jurisdiction is evaluated in accordance with the same set of rules that have been developed by the OECD/G20 Inclusive Framework members and not on a bilateral basis with each and every domestic law of the other jurisdictions.

122. In some cases, constitutional or other legal constraints may restrict a jurisdiction from referring directly to standards developed outside of that jurisdiction. In other words, the jurisdiction is not able to enact legislation that evaluate the IIR of another jurisdiction based on the GloBE Rules. Under these circumstances, jurisdictions may link the test for a Qualified IIR to the outcomes under their own legislation, based on the premise that their domestic rules are equivalent to the GloBE Rules and, accordingly, that any set of rules implemented under foreign law that produces the same outcomes as the GloBE Rules will also meet the domestic law test for a Qualified IIR. The reference to Article 2.1, which includes Article 2.1.6, clarifies that an IIR that does not apply to domestic LTCEs should still be considered a Qualified IIR. Accordingly, a jurisdiction that introduces an IIR that also applies to domestic subsidiaries should treat the IIR under the laws of a foreign jurisdiction as a Qualified IIR even if that IIR only applies to foreign operations.

123. The next part of the definition establishes a condition for an IIR to be “qualified”. It says that the jurisdiction shall not provide any benefits that are related to the IIR or the UTPR that it has implemented. This rule is intended to provide a level playing field in all the jurisdictions that have adopted these rules. The word “benefits” is comprehensive enough to cover any kind of advantage provided by a jurisdiction, including tax incentives, grants, and subsidies and the phrase “related to such rules” is intentionally drafted with broad language to take into account different mechanisms through which the benefit is provided.

124. For instance, assume a jurisdiction has adopted all of the provisions of the GloBE Rules in its legislation, including the ones in Article 2.1. However, it provides a tax credit equivalent to a portion of the tax paid under the IIR to be used against other taxes. In this case, the jurisdiction has not adopted a Qualified IIR.

125. Whether a benefit relates to the IIR must be determined based on the facts and circumstances of each case. It has to take into account the underlying principle behind this condition, which is to provide a level playing field among all jurisdictions and to avoid inversions incentivized by differences in the implementation and application of the GloBE Rules.

126. A tax benefit or grant provided to all taxpayers is not related to the GloBE Rules. Facts that are relevant but not decisive include whether the tax benefit or grant benefits only taxpayers subject to the GloBE Rules, whether the benefit is marketed as part of the GloBE Rules and if the regime was introduced after the OECD/G20 Inclusive Framework started discussing the GloBE Rules. In this context, the term “jurisdiction” is not restricted to the national or central government of the jurisdiction. It includes any political subdivision, local authority, or any other public entity or arrangement. For example, if a public development bank provides a particular benefit that is related to the application of the IIR, then such rule is not a Qualified IIR. .

127. The GloBE Implementation Framework will develop processes and provide guidance to facilitate the co-ordinated implementation of the GloBE Rules. This will include implementing a process to assist tax administrations in determining whether a country has introduced a Qualified IIR. In order to facilitate transparency, consistency and co-ordination, the outcome of these determinations will be released and made publicly available.

Qualified Imputation Tax

128. The GloBE Rules provide a specific definition of Qualified Imputation Tax that distinguishes it from a Disqualified Refundable Imputation Tax. Both of these taxes are imputation taxes, in the sense that they allow either the company or the shareholder to claim a full or partial credit or refund of the corporate income tax previously paid by the company when that income is subsequently distributed to the shareholder in the form of a dividend. Under a Disqualified Refundable Imputation Tax regime, however, the corporate tax previously paid may be refunded without subjecting the shareholders to tax on the dividend.

129. The definition of Qualified Imputation Tax and Disqualified Refundable Imputation Tax both require an examination of a jurisdiction's arrangements for the crediting and refunding of amounts of corporate tax paid through imputation systems. Once the features of a particular jurisdiction's arrangements are established to operate in the manner outlined in those definitions, or the extent to which it operates in such a manner, it is not necessary to test whether individual payments of tax, or individual credits or refunds are of the type mentioned in those definitions. Nonetheless, if the jurisdiction alters its domestic tax law for the crediting or refunding of corporate tax paid, or in respect of applicable tax rates, it will need to be re-determined whether those arrangements are, or are not, operating in the manner outlined in those definitions, or the extent to which it is or is not operating in that manner.

130. The definition of Qualified Imputation Tax has very specific requirements with regard to the taxation of the dividend recipients to ensure that the refund or credit is indeed a mechanism for ensuring a single level of tax. Under paragraphs (b) and (c) of the definition, the refund or credit must arise in connection with a dividend to a beneficial owner that:

- (b) is subject to a nominal rate of tax that equals or exceeds the Minimum Rate; or
- (c) is an individual that is resident in the jurisdiction of the distributing corporation and that is subject to tax on the dividend as ordinary income.

131. If the jurisdiction has a graduated rate structure, the nominal rate under paragraph (b) of the definition is the lowest rate applicable to the beneficial owner. The reference to taxation as ordinary income in paragraph (c) of the definition is intended to ensure that the dividend is not subject to low rates of tax only or specifically applicable to dividends or other passive income. Dividends distributed to a Governmental Entity, an International Organisation, a resident Non-profit Organisation, a resident Pension Fund or a resident Investment Entity that is not a Group Entity, do not need to be subject to tax in order for the regime to meet the criteria for a Qualified Imputation Tax regime. Dividends paid to life insurance companies that are treated similar to Pension Funds in respect of dividends it receives as part of a pension fund business are also exempt from the requirement to be taxed at the Minimum Rate.

132. In the event that a particular imputation system is not completely covered in the previous paragraph, (e.g. due to additional categories of shareholders not described in paragraphs (a) to (d) that may be eligible for a refund or credit), it may be necessary to then test to what extent a particular amount of Covered Tax is creditable or refundable in situations covered by paragraphs (a) to (d). In such cases, an amount of Covered Taxes can still be a Qualified Imputation Tax to the extent that the refund or credit of that tax is covered by paragraphs (a) to (d) of the definition. In applying paragraphs (a) to (d), an amount of Covered Tax can still be a Qualified Imputation Tax, notwithstanding a dividend has not yet been distributed, declared or paid, as long as there is a reasonable expectation that if distributed, the refund would be payable, or the credit would be creditable when distributed in the situations described in paragraphs (a) to (d).

133. The GloBE Implementation Framework will develop processes and provide guidance to facilitate the co-ordinated implementation of the GloBE Rules. This will include implementing a process to assist tax administrations in determining whether a tax regime is a Qualified Imputation Tax. In order to facilitate transparency, consistency and co-ordination, the outcome of these determinations will be released and made publicly available.

Qualified Refundable Tax Credit

134. The GloBE Rules include specific rules in Chapters 3 and 4 for the treatment of Qualified Refundable Tax Credits and Non-Qualified Refundable Tax Credits. A Qualified Refundable Tax Credit is treated as income for purposes of the GloBE Rules, which means the credit is taken into account in the denominator of the ETR computation and is not treated as reducing a Constituent Entity's taxes in the year the refund or credit is claimed. All other refundable tax credits (i.e. Non-Qualified Refundable Tax Credits) are excluded from income but treated as a reduction to Covered Taxes in the period the refund or credit is claimed, which means they reduce the numerator of the ETR computation. The distinction between "Qualified" and "Non-Qualified" Refundable credits, and their different treatment under specific rules in Chapters 3 and 4, ensure that refundable tax credits are properly accounted for in the computation of the GloBE Income or Loss and the determination of Adjusted Covered Taxes in a way that provides for transparent and predictable outcomes under the GloBE Rules.

135. In order to be treated as a Qualified Refundable Tax Credit under the GloBE Rules, the tax credit regime must be designed in a way so that a credit becomes refundable within 4 years from when the conditions under the laws of the jurisdiction granting the credit are met. Refundable means that the amount of the credit that has not been applied already to reduce Covered Taxes is either payable as cash or cash equivalent. For this purpose, cash equivalent includes checks, short-term government debt instruments, and anything else treated as a cash equivalent under the financial accounting standard used in the Consolidated Financial Statements as well as the ability to use the credit to discharge liabilities other than a Covered Tax liability. If the credit is only available to reduce Covered Taxes, i.e. it cannot be refunded in cash or credited against another tax, it is not refundable for this purpose. If the tax credit regime provides for an election by the taxpayer to receive the credit in a manner that is refundable, the tax credit regime is considered refundable to the extent of the refundable portion, regardless of whether any particular taxpayer elects refundability.

136. The conditions for a Qualified Refundable Tax Credit draw on the treatment in financial accounting standards (both for government grants and for income taxes), and are designed to identify tax credits that are, as a matter of substance and not merely form, likely to be refunded. However, in order to be treated as a Qualified Refundable Tax Credit under the GloBE Rules, the tax credit regime under the laws of a jurisdiction must be designed such that the refund mechanism has practical significance for those taxpayers that will be entitled to the credit. If the design of a tax credit regime is such that the credit will never exceed any taxpayer's tax liability (or it is intended that the credit will never exceed any taxpayer's tax liability), then, the refund mechanism will be of no practical significance to taxpayers and the GloBE Rules will not treat the credit as a Qualified Refundable Tax Credit. The assessment of whether a credit is refundable in the sense contemplated by the GloBE Rules must be made based on the conditions under which the credit is granted and on the information that was available at the time the credit was introduced into domestic law. This analysis is based on a qualitative assessment of the tax credit regime as a whole, and not on a taxpayer specific basis, however it should take into account circumstances under which the credit is made available. For example, a tax credit regime that was only available to a profitable taxpayer or group of taxpayers that were profitable (and excluded taxpayers that were not profitable) might include a refundable element that, in practice, can never result in the credit exceeding the taxpayer's tax liability. In contrast a tax credit regime that is generally available to taxpayers will not cease to be a Qualified Refundable Tax Credit simply because all the taxpayers that take advantage of that credit happen to be profitable.

137. The determination of whether a credit is refundable within 4 years is made at the time the conditions for granting the credit are met based on the law of the jurisdiction that granted the credit. Thus, in a situation where the Constituent Entity has incurred no tax or other liability to a government in the jurisdiction that granted the credit, a credit must be payable in cash or cash equivalents within 4 years from when the relevant conditions for granting the credit are met in order to be a Qualified Refundable Tax

Credit. Where the tax credit regime under the laws of a jurisdiction provides for a partial refund such that only a fixed percentage or portion of the credit is refundable, the refundable portion of the credit can be treated as a Qualified Refundable Tax Credit provided that portion will become refundable within 4 years from when the conditions for granting the credit under the laws of the jurisdiction granting the credit are met.

138. The provisions of Article 8.3 on Administrative Guidance will apply to ensure consistency of outcomes in respect of the application of this standard. If those jurisdictions that adopt the common approach identify risks associated with the treatment of tax credits and government grants that lead to unintended outcomes, the relevant jurisdictions could be asked to consider developing further conditions for a Qualified Refundable Tax Credit or, if necessary, explore alternative rules for the treatment of tax credits and government grants. This analysis would be based on empirical and historical data with respect to the tax credit regime as a whole, and not on a taxpayer specific basis.

Qualified UTPR

139. The GloBE Rules are intended to be implemented as part of a common approach. The common approach does not require jurisdictions to adopt the GloBE Rules, but, if a jurisdiction chooses to do so, it agrees to implement and administer them in a way that is consistent with these GloBE Rules. The GloBE Rules provide an interlocking set of rules that avoid multiple applications of these rules in respect of the same item of income through (i) an agreed rule order and (ii) an allocation of top-up tax where relevant. In particular, the UTPR allocates Top-up Tax among UTPR Jurisdictions, which are defined as jurisdictions that have a Qualified UTPR in force. For purposes of applying the UTPR under local law in each jurisdiction, it is therefore necessary to evaluate which Constituent Entities of the MNE Group are subject to a Qualified UTPR.

140. Under the definition set out in Article 10.1 of the GloBE Rules, a Qualified UTPR means:

“...a set of rules equivalent to Article 2.4 to Article 2.6 of the GloBE Rules (including any provisions of the GloBE Rules associated with those articles) that are included in the domestic law of a jurisdiction and that are implemented and administered in a way that is consistent with the outcomes provided for under the GloBE Rules and the Commentary, provided that such jurisdiction does not provide any benefits that are related to such rules.”

141. The definition prohibits a jurisdiction from providing benefits that are related to the IIR or the UTPR that it has implemented. See discussion on this in the Commentary to the definition of a Qualified IIR.

142. This definition does not compare the UTPR under local law with the equivalent provision implemented in another jurisdiction. Rather it compares the UTPR adopted in the domestic law of a jurisdiction with the GloBE Rules and their Commentary as developed by the OECD/G20 Inclusive Framework on Base Erosion and Profit Shifting. In some cases, constitutional or other legal constraints may restrict a jurisdiction from referring directly to standards developed outside of that jurisdiction. In other words, the jurisdiction is not able to enact legislation that evaluate the UTPR of another jurisdiction based on the GloBE Rules. Under these circumstances, jurisdictions may link the test for a Qualified UTPR to the outcomes under their own legislation.

143. The GloBE Implementation Framework will provide for guidance and processes agreed by the Inclusive Framework on BEPS to facilitate the co-ordinated implementation of the GloBE Rules. This will include guidance and processes to determine whether a set of rules is considered as a Qualified UTPR. The ability of a UTPR Jurisdiction to collect the UTPR Top-Up Tax Amount (taking into consideration, for example, any relevant domestic statute of limitations) that it would be allocated should be taken into account in order to determine whether a jurisdiction has a Qualified UTPR. In order to facilitate compliance by MNEs and administration by tax authorities, the outcome of these determination would be released and made publicly available.

Real Estate Investment Vehicle

144. As with Investment Funds, a Real Estate Investment Vehicle that is the UPE of an MNE Group is an Excluded Entity in accordance with Article 1.5.1. While in many cases, these investment vehicles would qualify as Excluded Entities by virtue of being Investment Funds, in certain cases Real Estate Investment Vehicles may not be subject to the necessary regulation or managed by investment fund management professionals to satisfy the requirements terms of paragraph (f) or (g) of the Investment Fund definition. Accordingly Real Estate Investment Vehicles are also identified under the GloBE Rules as a separate category of Excluded Entity under Article 1.5.1.

145. A Real Estate Investment Vehicle is a widely-held Entity that holds predominantly immovable property. The definition in the GloBE Rules draws on the “special tax regime” provision included in paragraph 86 of the Commentary on Article 1 of the OECD Model Tax Convention (OECD, 2017^[1]). A widely-held Entity is one that has many owners that are not connected persons. For this purpose, an owner should be treated as connected to another owner if it meets the test set out in Article 5(8) of the OECD Model Tax Convention. A Real Estate Investment Vehicle that is owned directly by a small number of other widely-held Investment Entities or Pension Funds that have numerous beneficiaries is considered to be widely-held.

146. One of the conditions set out in the definition is that Real Estate Investment Vehicle achieves a single level of taxation (with at most one year of deferral). The intention of this language is to deal with tax neutral vehicles which are designed to ensure that a single level of taxation is achieved either in the hands of the vehicle or its equity interests holders. This could be the case of an exempt entity provided that it distributes its income within a time period. The distribution is then subject to tax in order to achieve a single level of taxation. Furthermore, this also includes where part of the income is subject to tax at the fund level and the remaining part at the investor level.

147. In some situations, however, the Interest holders could also be tax neutral vehicles such as a recognised Pension Fund. In these cases, on a strict reading, a single level of taxation would not be achieved within a year as the distributions made to these investors could be exempted. However, the definition would still be met because the design of the tax regime was to achieve a single level of taxation.

148. The definition also requires that the Entity holds predominantly immovable property. In some cases, such property would not be held directly but indirectly via holding a security the value of which is linked to immovable property. An Entity that holds predominantly immovable property, either directly or indirectly via such securities (or a combination of the two) will meet the condition the definition.

Tax Treaty

149. The term Tax Treaty is broadly defined in the GloBE Rules. It means an agreement for the avoidance of double taxation with respect to taxes on income including any modifications to that treaty by any subsequent protocol or the Multilateral Convention to Implement Tax Treaty Related Measures to Prevent Base Erosion and Profit Shifting. It also includes any other type of agreements with clauses to avoid double taxation with respect to taxes on income such as an Air Traffic Agreement if such clauses are relevant for purposes of the GloBE Rules.

Article 10.2 - Definitions of Flow-through Entity, Tax Transparent Entity, Reverse Hybrid Entity, and Hybrid Entity

150. Article 10.2 contains the definitions of the terms Flow-through Entity, Tax Transparent Entity, Reverse Hybrid Entity and Hybrid Entity. These terms are used in different parts of the GloBE Rules, in

particular, in Article 3.5 that regulates the allocation of the Financial Accounting Net Income or Loss of Flow-Through Entities and Article 7.1 that applies to UPEs that are Flow-through Entities.

Article 10.2.1

151. Article 10.2.1 defines the term Flow-through Entity. The provision treats an Entity as a Flow-through Entity to the extent that it is fiscally transparent with respect to its income, expenditure, profit or loss in the jurisdiction where it was created. An example of a Flow-through Entity is a fiscally transparent partnership. The test for whether an Entity is treated as fiscally transparent is explained further in the Commentary to Article 10.2.2 below.

152. The last part of the sentence of Article 10.2.1 establishes an exception to the definition. It states that an Entity is not a Flow-through Entity if it is a tax resident and subject to a Covered Tax on its income or profit in another jurisdiction. For example, assume an Entity incorporated in Country A has its place of effective management in Country B. The Entity has elected to be treated as fiscally transparent in Country A (the jurisdiction where it was created). The tax residency test in Country B is place of effective management and therefore, Country B taxes the Entity as a tax resident. In this case, the Entity would not be a Flow-through Entity under the GloBE Rules because it is a tax resident of Country B.

153. Part of this exception requires the Entity to be subject to a Covered Tax in the jurisdiction where it is resident. This ensures that the Entity is not only considered as a tax resident but effectively subject to a Covered Tax in that jurisdiction even if it does not pay tax in a particular Fiscal Year because, for example, it is in a loss position.

154. Flow-through Entities can further be divided into two categories: Tax Transparent Entities and Reverse Hybrid Entities. The difference between these terms depends on how the direct owners (i.e. holders of their Ownership Interest) are treating them under their domestic tax law.

155. A Flow-through Entity is a Tax Transparent Entity if the domestic tax law of the owners also treat it as fiscally transparent and require the owner to recognize the income, expenditure, profit or loss of the Flow-through Entity as if it was income earned or expenditure borne by the owners.

156. On the other hand, a Flow-through Entity is a Reverse Hybrid Entity if the domestic tax law of the owners are not treating it as fiscally transparent and therefore, it does not recognize the income, expenditure, profit or loss when earned or incurred by the Entity, but until the Entity distributes profits or make an equivalent payment to its owners.

157. All three definitions include the phrases “with respect to its income, expenditure, profit or loss” and “to the extent that”. These phrases ensure that the rules in Article 10.2 can apply to an entity in relation to a specific item of income or expenditure or a portion of its profit or loss. The application of this language to different situations is described below.

158. In the case of the definition of a Flow-through Entity, the phrases “with respect to its income, expenditure, profit or loss” and “to the extent” cover the situation in which the jurisdiction where the Entity is created does not treat the Entity as entirely fiscally transparent. For instance, the jurisdiction where a trust is created treats that trust as fiscally transparent only with respect to the income that it treats as income of a beneficiary. The income not attributable to the beneficiary is treated as taxable at the trust level. In this case, the trust is a Flow-through Entity but only to the extent and with respect of the beneficiary income. The trust is not considered as a Flow-through Entity to the extent and with respect to the income that is taxed at the trust level.

159. In the case of the definitions of Tax Transparent Entity and Reverse Hybrid Entity, these phrases accommodate the case where the same Flow-through Entity is treated differently by owners that are tax resident in different jurisdictions and therefore apply different entity characterisation rules to the same Entity such that the same Entity is treated as a Tax Transparent Entity and a Reverse Hybrid Entity in

respect of different owners. For example, when applying Article 3.5.1, the Financial Accounting Net Income or Loss attributable to the owners that treat the Flow-through Entity as a Tax Transparent Entity is allocated to such owners in accordance with Article 3.5.1(b). The Financial Accounting Net Income or Loss attributable to the owners that treat the Flow-through Entity as a Reverse Hybrid Entity is allocated to the Entity in accordance with Article 3.5.1 (c).

Article 10.2.2

160. Article 10.2.2 describes what is meant by fiscally transparent in Articles 10.2.1 and 10.2.5. It states that an Entity is treated as fiscally transparent under the laws of a jurisdiction, if such jurisdiction treats the income, expenditure, profit or loss of that Entity as if they were derived or incurred by the direct owner of the Entity in proportion to its interest.

161. An Entity is treated as fiscally transparent in the jurisdiction in which it is created if that jurisdiction does not impose a Covered Tax on the Entity and treats the owners of the Entity as earning their respective shares of the Entity's income directly for purposes of that Covered Tax. This rule does not require the jurisdiction to treat the owners as incurring their respective shares of the Entity's net losses. Accordingly an Entity may also be considered fiscally transparent where the laws of the jurisdiction where it is established allow for the pass-through of income but requires net losses to be carried forward by the Entity itself and taken into account in the computation of the Entity's income in a subsequent period. An example of this kind of Entity can be a trust which allocates income of a specific category or class to certain beneficiaries but it is allowed to carry forward any net loss from one taxable year to the next one in order to be offset against future income in that year. An Entity should not be treated as fiscally transparent under the laws of a jurisdiction solely because it is treated for tax purposes in that jurisdiction as forming part of another Constituent Entity because it is a member of a tax consolidated group.

162. An Entity may be subject to Covered Tax at a local, state or regional level but treated as fiscally transparent for tax purposes under national or federal law. Such an Entity may still be treated as fiscally transparent under GloBE with respect to its income or profits even if those amounts are subject to a Covered Tax imposed by a local or sub-national tax authority in the same jurisdiction.

163. An Entity is fiscally transparent in the jurisdiction in which the owner is located if the owner is subject to tax on its share of the Entity's income or loss in its tax jurisdiction in a similar manner as if the owner directly earned its share. The owner is subject to tax in a similar manner if it is subject to tax on all of the income items of the Entity, which may be net of expenses and losses applied in that Entity, that would have been subject to tax if they had been earned directly by the owner. However, the item of income that has been passed through to the owner on an item-by-item basis does not need to be subject to tax as if it were taxed at the Entity level. For example, a jurisdiction may impose limitations on capital losses incurred by an Entity that are different from the limitations imposed on capital losses incurred directly by the owner.

Article 10.2.3

164. Article 10.2.3 defines a Tax Transparent Structure as a chain of Tax Transparent Entities through which an owner has an Ownership Interest in an Entity or a PE. This term is used in Article 3.5.3 to describe the situation in which a non-member of the MNE Group has an Ownership Interest in a Flow-through Entity through a Tax Transparent Structure.

Article 10.2.4

165. Article 10.2.4 is a deeming provision that treats a Constituent Entity as a Flow-through Entity and Tax Transparent Entity if such Entity has no tax residency and is not subject to a Covered Tax or a Qualified Domestic Minimum Tax, and its owners treats it as fiscally transparent. The most common case covered

by this provision is where a Constituent Entity, with no tax residency, is created in a jurisdiction with no CIT and its owners treat that Entity as fiscally transparent. This scenario is not covered by Article 10.2.1 because these Entities are not fiscally transparent in the jurisdiction where they are created because they are not subject to a CIT legislation that treats their income, expenditure, profit or loss as derived or incurred by its owners.

166. Article 10.2.4 is only triggered if several conditions are met. First, the Constituent Entity shall not have a tax residence and not subject to a Covered Tax or a Qualified Domestic Minimum Top-up Tax based on its place of management, creation or similar criteria. Second, the jurisdiction of its owners shall treat the Entity as fiscally transparent. Third, Entity shall not have a place of business in the jurisdiction where it is created. Lastly, its income, expenditure, profit or loss shall not be attributable to a PE. The last three conditions are described in paragraphs (a) to (c) of the provision.

167. Similar to Article 10.2.1, Article 10.2.4 applies in respect of the income, expenditure, profit or loss of the Entity to the extent that the conditions in paragraphs (a) to (c) are met. Thus, an Entity could be treated as a Flow-through Entity and Tax Transparent Entity, and at the same time, treated as an Entity that is not a Flow-through Entity. In the latter case, the Entity is not treated as a Reverse Hybrid Entity because it is not a Flow-through Entity (i.e., the jurisdiction of creation does not treat the income, expenditure, profit or loss as derived or incurred by its owners).

168. For example, C Co is a Constituent Entity created in Country C, a jurisdiction with no CIT. C Co has no place of business in the jurisdiction where it was created and its income is not attributable to a PE. The Ownership Interests of C Co are equally distributed among A Co and B Co, which are Constituent Entities of the same MNE Group. A Co is a resident of Country A, which treats C Co as fiscally transparent. B Co is a resident of Country B, which does not treat C Co as fiscally transparent. In this case, only 50% of the income of C Co is treated as being derived by a Tax Transparent Entity (which is subject to Article 3.5). The remaining 50% of the income of C Co is treated as being derived by an Entity that is not a Flow-through Entity (not subject to Article 3.5).

Article 10.2.5

169. Article 10.2.5 defines a Hybrid Entity as an Entity that is treated as a separate taxable person for income tax purposes in the jurisdiction where it is located (i.e. a tax resident) but treated as fiscally transparent in the jurisdiction where its owners are located. Similar to other definitions in Article 10.2, the phrase “with respect to its income, expenditure, profit or loss to the extent that it is fiscally transparent in the jurisdiction in which its owner is located” allows that an Entity can be considered a Hybrid Entity only with respect to the owners that treat it as fiscally transparent. The term Hybrid Entity is relevant for purposes of Article 4.3.2 (d).

Article 10.3 - Location of an Entity and a Permanent Establishment

170. Article 10.3 sets out the rules that determine the location of an Entity and a PE for purposes of the GloBE Rules. Determining the location of an Entity and PE is important for jurisdictional blending and for determining where the Top-up Tax has to be paid. Article 10.3 does not affect the domestic and treaty provisions, such as those dealing with tax residence and source taxation.

171. Article 10.3 has two types of provisions:

- a. The first provides the rule for where an Entity is located for purposes of the GloBE Rules (Articles 10.3.1 to 10.3.3 and 10.3.7);
- b. The second provides tie-breaker rules in the event a Constituent Entity is considered to be located in more than one jurisdiction (Articles 10.3.4 to 10.3.6).

172. The principle underlying the rules is to follow the treatment under local law. The rules give a priority to tax residence whenever possible. In most cases, an Entity will be a tax resident in a jurisdiction, and that will be its location for the purpose of the GloBE Rules. In the event that there is no tax residence, the location will be the place of creation. In the case of Flow-through Entities, these are considered to be located in the jurisdiction where they are created if they are the UPE or required to apply the IIR. In all other cases they are stateless Entities. In the case of a PE, in most cases it will be located in the place of business (as determined by the applicable Tax Treaty, domestic taxing rules or physical location). In limited cases, a PE will be stateless.

173. It is possible that the local law treatment results in an Entity being located in more than one jurisdiction. The GloBE tiebreaker rules follow the result of a tiebreaker that applies under an applicable Tax Treaty. If there is no result from the applicable Tax Treaty, then the Entity is located in the place with higher Covered Taxes or higher Substance (calculated under the Substance-based Income Exclusion), in that order. In limited cases, the Entity will be stateless.

174. The GloBE Rules also provide special rules for the treatment of a “stateless” Entity. These rules treat the income and taxes allocated of a Stateless Constituent Entity as subject to a stand-alone top-up tax calculation. The reason for taxing the GloBE Income allocated to a stateless Constituent Entity on a stand-alone basis is that this income will generally be “stateless income” (i.e. not treated under the laws of any jurisdiction as income of a resident taxpayer or a PE). The GloBE Rules identify two situations where a Constituent Entity could be treated as “stateless”:

- a. the Constituent Entity is a Flow-through Entity identified in Article 10.3.2(b); or
- b. The Constituent Entity is a PE as defined by paragraph (d) of its definition in Article 10.1 (see Article 10.3.3 (d)).

175. The income and taxes allocated to a Stateless Constituent Entity are brought into account for GloBE purposes on a standalone basis.

176. The rules for allocating income and taxes in respect of a Flow-through Entity are set out in Articles 3.5 and 4.3.2(b). In practice, the only case where the allocation of income to a Flow-through Entity will give rise to stateless income is where the Entity is a Reverse Hybrid Entity such that neither of the jurisdictions where the Entity is created or where the owners are located recognizes the income as income of a resident taxpayer. In the case of stateless PEs, the income and taxes allocated to the PE in accordance with Article 3.4.3 will be treated as stateless income and subject to a separate jurisdictional blending calculation. In this case, the residence jurisdiction is exempting the income on the grounds that the income is attributable to a foreign PE that is not recognised under the laws of another jurisdiction. Therefore, the income becomes “stateless income” under the GloBE Rules because it does not belong to a resident taxpayer or a PE.

177. The term “jurisdiction” is not defined in Article 10.1 or any other provision in the GloBE Rules. The approach that has been taken is to follow the definition of “Tax Jurisdiction” used for CbCR, and thus a jurisdiction for purposes of the GloBE Rules means a State as well as a non-State jurisdiction which has fiscal autonomy.

Article 10.3.1

178. Article 10.3.1 is the main rule for determining the location of an Entity that is not a Flow-through Entity. Article 10.3.1 applies to Constituent Entities that are not PEs. The provision is divided into two paragraphs.

Paragraph (a)

179. Paragraph (a) states that an Entity is located in the jurisdiction where it is considered as a tax resident based on its place of management, place of creation, or similar criteria. Whether a Constituent Entity is a resident of a jurisdiction depends on the domestic law of each jurisdiction.

180. Paragraph (a) does not require the Entity to be a legal person provided that it is considered a tax resident in a jurisdiction. For example, a partnership that is considered a tax resident in a jurisdiction would be within the scope of this paragraph. On the other hand, a corporation considered as a Flow-through Entity would fall outside this paragraph.

181. The reference to “place of management and place of creation” are non-exhaustive examples of criteria typically used by jurisdictions in their domestic tax residency rules. The words “place of creation” is used in paragraph (a) because it covers terms such as place of incorporation and place of organisation. The words “or similar criteria” allows for other criteria used in domestic tax residency rules to be taken into account, such as domicile and registration.

182. An Entity will be a tax resident if it is tax resident according to national / federal law. For example, a Constituent Entity may be a Flow-through Entity for purposes of federal or national tax law, but considered as a tax resident under local or sub-national tax law. In these cases, such Entities would not be a resident of the jurisdiction within the scope of paragraph (a).

183. Some jurisdictions may permit an Entity organised outside of the jurisdiction to make an election to claim tax residency in that jurisdiction. Such an election, on its own, is not dispositive of location for purposes of Article 10.3.1 and does not rise to the level of “other similar criteria”.

Paragraph (b)

184. Paragraph (b) states that in all other cases, an Entity that is not a Flow-through Entity is located in a jurisdiction where it was created. This would be the case of Entities created in jurisdictions with no CIT System.

Article 10.3.2

185. Article 10.3.2 refers to the location of an Entity that is a Flow-through Entity. The term Flow-through Entity is defined in Article 10.2 and can be divided into Tax Transparent Entities and Reverse Hybrid Entities. This provision does not apply to a PE through which the Flow-through Entity wholly or partly carries out its business. Article 10.3.2 is divided into two paragraphs.

Paragraph (a)

186. Paragraph (a) states that if the Flow-through Entity is the UPE or is required to apply the IIR, then it would be located in the jurisdiction where it is created.

187. In most cases, it is expected that jurisdictions may not require a Flow-through Parent Entity to apply the IIR because they are not taxable persons. However, some jurisdictions may wish to require these Entities to apply the IIR. If this the case, such Entity would be located in its jurisdiction of creation and therefore, it would be require to apply the IIR in such jurisdiction.

Paragraph (b)

188. Paragraph (b) states that in all other cases, the Flow-through Entity is considered as a stateless Entity. However, the Financial Accounting net Income or Loss of a Flow-through Constituent Entity may not be “stateless income” if it has been allocated to a different Constituent Entity under Article 3.5. The

characterisation and treatment of Stateless Constituent Entities is described in the general Commentary to Article 10.3.

Article 10.3.3

189. Article 10.3.3 deals with the location of a PE. This provision should be read in conjunction with other provisions of the GloBE Rules dealing with PEs such as the definition of PE in Article 10.1 and Constituent Entity in Article 1.3.

190. Article 10.3.3 is divided into the following paragraphs (which correspond to the four types of PE as provided in the definition in Article 10.1).

191. Paragraph (a) determines the location of a PE when the PE meets the definition in paragraph (a) of Article 10.1. This paragraph of the PE definition refers to a PE that is subject to tax on its net income in the source jurisdiction in accordance with a Tax Treaty in force between the source and residence jurisdiction. In this case, the GloBE Rules apply the outcome provided for under the Tax Treaty and the PE is treated as located in the source jurisdiction.

192. Paragraph (b) determines the location of a PE when it meets the definition in paragraph (b) of Article 10.1. This paragraph of the PE definition refers to a PE that is subject to tax on its net income in the source jurisdiction but there is no Tax Treaty in force between the source and residence jurisdiction. In this situation, the PE is located in the source jurisdiction.

193. Paragraph (c) determines the location of a PE when it meets the definition in paragraph (c) of Article 10.1. This paragraph of the PE definition refers to a PE that is not subject to tax on its net income in the source jurisdiction because the jurisdiction has no CIT system. In such cases, Article 10.1 says that a PE is deemed to exist for purposes of the GloBE Rules if the source jurisdiction would have treated it as a PE in accordance with the OECD Model Tax Convention and had the right to tax the income attributable to it in accordance with Article 7. In this case, it would be located in the jurisdiction that does not have a CIT.

194. Finally, paragraph (d) determines the location of a PE when it meets the definition in paragraph (d) of Article 10.1. This paragraph of the PE definition only applies to PEs that are not described in the other paragraphs of the PE definition. As noted in the Commentary to Article 10.1, Paragraph (d) of the PE definition deems a PE to be established for purposes of the GloBE Rules where the law of the residence jurisdiction exempts the income from a resident's operations (or a portion of its operations) on the grounds that they are conducted outside of the residence jurisdiction. Where a PE arises under paragraph (d) of the PE definition Article 10.3.3(d) provides that such deemed PEs are stateless.

Article 10.3.4

195. Article 10.3.4 addresses the case where a Constituent Entity, other than a PE, is located in two or more jurisdictions in accordance with Article 10.3.1 (i.e. a resident in more than one jurisdiction). For example, a Constituent Entity may be incorporated in one jurisdiction and have its place of effective management in another, and treated as tax resident in both jurisdictions under the respective domestic definitions of tax residence.

196. This outcome is incompatible with the GloBE Rules for two reasons: 1) the tax attributes of a Constituent Entity can only be considered in one jurisdiction for purposes of the ETR and Top-up Tax computation; 2) a Constituent Entity can only be required to apply the IIR or UTPR in one jurisdiction to avoid double taxation.

197. To resolve this conflict, Article 10.3.4 determines the location of the Constituent Entity for the purpose of the GloBE Rules. This provision does not impact the taxation rights that jurisdictions have under their domestic law. Article 10.3.4 addresses two scenarios:

- a. situations in which a Tax Treaty in force exists; and
- b. situations in which no treaty applies.

198. Article 10.3.4 applies for each fiscal year. This means that a Constituent Entity can be located in different jurisdictions in different fiscal years depending on the outcome under the tie breaker rule. For example, where a Tax Treaty comes into force in a subsequent year, or when a Competent Authority Agreement is reached in a subsequent year, and resolves the case differently than was the result under paragraph (b). Similarly, where a Competent Authority Agreement or court decision resolves a case of dual residence and this decision applies retroactively, this may affect the GloBE computations (such as the ETR computation of the jurisdictions involved, computation of the Top-up Tax of the Constituent Entity, or where the Top-up Tax is paid). If the Competent Authority Agreement applies retroactively, any tax owed or refunded in connection with the agreement may also require an adjustment under Article 4.6 and a recalculation of the ETR and Top-up Tax under Article 5.4.1.

Applicable Tax Treaty in force

199. Paragraph (a) applies where the jurisdictions in which the Constituent Entity would otherwise be treated as being located have a Tax Treaty in force and its relevant provisions have come into effect.

200. Two outcomes are possible in this case. First, that the relevant Tax Treaty resolves the dual residence (for example, by virtue of a provision similar to Article 4(3) of the OECD Model Tax Convention (OECD, 2017^[1])). In this case, the GloBE Rules follow the outcome of a treaty. This is so irrespective of the type of tiebreaker rule contained in the relevant Tax Treaty (for example, a provision resolving dual residence in favour of the place of effective management, or resolving dual residence by virtue of an agreement reached between the two competent authorities).

201. Second, that the relevant Tax Treaty does not resolve the dual residence (for example, the procedure to reach the agreement has not been initiated, no agreement has been reached between the competent authorities or where the tiebreaker rule says that the Constituent Entity shall not be treated as a resident of either of the jurisdictions for purposes of the treaty). In these cases, Article 10.3.4 (b) applies as if there was no applicable Tax Treaty in force.

No Applicable Tax Treaty in force

202. Article 10.3.4(b) deals with cases where a Tax Treaty does not apply (whether there is no Tax Treaty in force, or because the provisions of the Tax Treaty did not apply or did not resolve the dual residence). It provides a cascading set of rules to resolve the location of the Constituent Entity.

203. The starting point is that Article 10.3.4(b)(i) provides that the Constituent Entity shall be located in the jurisdiction where it paid the greater amount of Covered Taxes for the fiscal year. This rule compares only the amount of Covered Taxes paid in the jurisdictions where the Constituent Entity would otherwise be located. It does not take into account any foreign taxes paid outside those jurisdictions (including withholding taxes), including those that have benefited from a foreign tax credit in those jurisdictions. Furthermore, Article 10.3.4(b)(i) does not take into account taxes paid in accordance with CFC Tax Regime.

204. Article 10.3.4(b)(i) compares “taxes paid” for the Fiscal Year of the MNE Group. For this purpose, “taxes paid” refer to the Covered Taxes that are paid or due to be paid in each jurisdiction for a particular Fiscal Year. The information is taken from the tax returns that the Entity files or will file in each jurisdiction. Where the taxable year is different to the Fiscal Year, then the amount of taxes should be prorated and assigned to the number of months that correspond to the Fiscal Year. For instance, a Constituent Entity paid 120 of taxes for the first taxable year and 60 for the second taxable year. The taxable year runs from July 1 to June 30. The Fiscal Year equals the calendar year. In this case, the Fiscal Year runs between two taxable years. The amount of tax paid for the Fiscal Year is $90 [(120/12)6 + (60/12)6]$.

205. If the amount of Covered Taxes paid in both jurisdictions is the same or zero, then Article 10.3.4(b)(ii) provides that the Constituent Entity shall be located where it has the greater amount of Substance-based Income Exclusion, computed on an entity basis, in accordance with Article 5.3. This subdivision requires a special computation for purposes of determination of the location of the Constituent Entity, because ordinarily the computation under Chapter 5 would be on a jurisdiction basis, rather than on a standalone entity basis.

206. If neither of these two criteria resolve the conflict, then Article 10.3.4(b)(iii) provides that the Constituent Entity shall be considered as stateless. This is the case unless it is the UPE of the MNE Group, in which case it shall be located in the jurisdiction where it was created.

More than two jurisdictions involved

207. Article 10.3.4 also applies to cases where a Constituent Entity is considered to be located in more than two jurisdictions. First, to the extent that there are tax treaties that apply between the relevant jurisdictions, the provisions of those treaties would apply as per paragraph (a). Thereafter, if the issue has not been fully resolved by the application of the relevant treaties, then paragraph (b) will apply.

Article 10.3.5

208. The tie-breaker rule in Article 10.3.4 can result in locating a Parent Entity in a jurisdiction where it would not be subject to apply a Qualified IIR. Under these circumstances, Article 10.3.5 derogates from the outcomes under Article 10.3.4 and allows the other jurisdiction to impose its Qualified IIR on such a Parent Entity. Article 10.3.5 does not change the jurisdiction where the Constituent Entity is located for purposes of computation of the ETR and Top-up Tax. It only allows the other jurisdiction to apply a Qualified IIR.

209. The operation of Article 10.3.5 may be restricted by the application of a Tax Treaty. Where the result of the application of the tiebreaker rule in a Tax Treaty is that the Constituent Entity is resident in one jurisdiction, but not resident in the other, then under the terms of that treaty (provisions equivalent to Articles 7 or 21 of the OECD Model Tax Convention (OECD, 2017^[1])), that second jurisdiction may not be permitted to tax the Constituent Entity as its resident, including applying the IIR. Where, the tiebreaker rule in the Tax Treaty follows or is similar to Article 4(3) of the 2017 OECD Model Tax Convention (which requires an agreement between the competent authorities) such an agreement could provide that it does not restrict a jurisdiction from applying a Qualified IIR where the other jurisdiction has not adopted a Qualified IIR. Alternatively, if no Competent Authority Agreement has been reached and the Constituent Entity is not entitled to any relief or exemption from tax, then nothing restricts the other jurisdiction (under the GloBE tiebreaker rule) from applying the GloBE Rules. In this case, such restriction would not apply because the Tax Treaty would not be prohibiting the application of the GloBE Rules and therefore, Article 10.3.5 still applies.

Article 10.3.6

210. Article 10.3.6 refers to the case where an Entity changes its location during a Fiscal Year. In these cases, Article 10.3.6 states that it should be located in the jurisdiction of departure for that Fiscal Year. For the next Fiscal Year, the Entity would be located in the jurisdiction of arrival.

References

European Union (2011), *Directive 2011/61/EU of the European Parliament and of the Council of 8 June 2011 on Alternative Investment Fund Managers and amending Directives* [7]

2003/41/EC and 2009/65/EC and Regulations (EC) No 1060/2009 and (EU) No 1095/2010, <http://data.europa.eu/eli/dir/2011/61/oj>.

IFRS Foundation (2022), *International Financial Reporting Standards*, <https://www.ifrs.org/>. [2]

IWG (2008), *Sovereign Wealth Funds: Generally Accepted Principles and Practices - "Santiago Principles"*, <https://www.ifswf.org/santiago-principles-landing/santiago-principles>. [9]

OECD (2017), *Model Tax Convention on Income and on Capital: Condensed Version 2017*, OECD Publishing, Paris, https://dx.doi.org/10.1787/mtc_cond-2017-en. [1]

Notes

¹ See International Working Group of Sovereign Wealth Funds, *Sovereign Wealth Funds: Generally Accepted Principles and Practices - "Santiago Principles"* (IWG, 2008^[8]), October 2008, Annex 1; also replicated in 2017 Model Tax Convention (OECD, 2017^[1]), Commentary on Article 4, paragraph 8.5.

Tax Challenges Arising from the Digitalisation of the Economy – Commentary to the Global Anti-Base Erosion Model Rules (Pillar Two)

INCLUSIVE FRAMEWORK ON BEPS

A key part of the OECD/G20 BEPS Project is addressing the tax challenges arising from the digitalisation of the economy. In October 2021, over 135 jurisdictions joined a ground breaking plan to update key elements of the international tax system which is no longer fit for purpose in a globalised and digitalised economy. The Global Anti-Base Erosion Rules (GloBE), published in December 2021, are a key component of this plan and ensure large multinational enterprise pay a minimum level of tax on the income arising in each of the jurisdictions where they operate. More specifically, the GloBE Rules provide for a co-ordinated system of taxation that imposes a top-up tax on profits arising in a jurisdiction whenever the effective tax rate, determined on a jurisdictional basis, is below the minimum rate. This Commentary to the GloBE Rules provides tax administrations and taxpayers with guidance on the interpretation and application of those rules in order to promote a consistent and common interpretation of the GloBE Rules that will facilitate co-ordinated outcomes for both tax administrations and MNE Groups. This Commentary explains the intended outcomes under the GloBE Rules and clarifies the meaning of certain terms. It also illustrates the application of the rules to certain fact patterns.



For more information:

 ctp.contact@oecd.org

 www.oecd.org/tax/beps

 [@OECDtax](https://twitter.com/OECDtax)

 [OECD Tax](https://www.linkedin.com/company/oecd-tax)

OECD/G20 BASE EROSION AND PROFIT SHIFTING PROJECT

Tax Challenges Arising from the Digitalisation of the Economy – Global Anti-Base Erosion Model Rules (Pillar Two) Examples

INCLUSIVE FRAMEWORK ON BEPS



OECD/G20 Base Erosion and Profit Shifting Project

**Tax Challenges Arising from the
Digitalisation of the Economy –
Global Anti-Base Erosion Model Rules
(Pillar Two) Examples**

Inclusive Framework on BEPS

This document and any map included herein are without prejudice to the status of or sovereignty over any territory, to the delimitation of international frontiers and boundaries and to the name of any territory, city or area.

This document was prepared for publication by the OECD Secretariat.

Please cite this document as:

OECD (2022), *Tax Challenges Arising from the Digitalisation of the Economy – Global Anti-Base Erosion Model Rules (Pillar Two) Examples*, OECD, Paris, <https://www.oecd.org/tax/beps/tax-challenges-arising-from-the-digitalisation-of-the-economy-global-anti-base-erosion-model-rules-pillar-two-examples.pdf>.

Photo credits: Cover © ninog – Fotolia.com.

© OECD 2022

The use of this work, whether digital or print, is governed by the Terms and Conditions to be found at www.oecd.org/termsandconditions

Table of contents

| | |
|----------------------------|----|
| Abbreviations and acronyms | 4 |
| Introduction | 5 |
| Chapter 2 – Examples | 6 |
| Article 2.1.3 | 6 |
| Article 2.1.5 | 8 |
| Article 2.2.3 | 10 |
| Article 2.2.4 | 12 |
| Article 2.3.2 | 13 |
| Article 2.4.1 | 16 |
| Article 2.4.2 | 18 |
| Article 2.5.3 | 19 |
| Article 2.6.4 | 20 |
| Chapter 3 – Examples | 23 |
| Article 3.2.1(b) | 23 |
| Article 3.2.1(f) | 25 |
| Article 3.2.3 | 28 |
| Article 3.2.7 | 30 |
| Article 3.3.1 | 32 |
| Chapter 4 – Examples | 34 |
| Article 4.1.3 | 34 |
| Article 4.1.5 | 35 |
| Article 4.3.3 | 38 |
| Article 4.4.1 | 39 |
| Chapter 5 - Examples | 41 |
| Article 5.3.7 (a) | 41 |
| Article 5.5.2 | 42 |
| Chapter 6 - Examples | 43 |
| Article 6.2.1 (e) | 43 |
| Chapter 7 – Examples | 44 |
| Article 7.1.1 (a) | 44 |
| Article 7.1.4 | 46 |
| Article 7.3 | 47 |

Abbreviations and acronyms

| | |
|--------------|--|
| BEPS | Base Erosion and Profit Shifting |
| CFC | Controlled foreign company |
| CIT | Corporate income tax |
| ETR | Effective tax rate |
| FX | Foreign exchange |
| FXGL | Foreign currency gains or losses |
| GloBE | Global Anti-Base Erosion |
| IIR | Income Inclusion Rule |
| LTCE | Low-Taxed Constituent Entity |
| MNE | Multinational Enterprise |
| OECD | Organization for Economic Co-operation and Development |
| PE | Permanent Establishment |
| POPE | Partially-Owned Parent Entity |
| UPE | Ultimate Parent Entity |

Introduction

1. The Global Base Erosion rules (GloBE Rules) have been developed as part of the solution for addressing the tax challenges of the digital economy. They are designed to ensure large multinational enterprises (MNEs) pay a minimum level of tax on the income arising in each jurisdiction where they operate. The Commentary to the GloBE Rules provides tax administrations and taxpayers with guidance on the interpretation and application of those rules. The Commentary is intended to promote a consistent and common interpretation of the GloBE Rules that will facilitate co-ordinated outcomes for both tax administrations and MNE Groups. The Commentary explains the intended outcomes under the rules and clarifies the meaning of certain terms.

2. This document, which has been prepared by the OECD Secretariat, sets out a number of examples that illustrate application of the GloBE Rules. The numbering of the examples is consistent with the relevant provisions of the GloBE Rules and the Articles in the Commentary to the GloBE Rules Articles. The examples are intended to be used for illustrative purposes only and do not form part of the Commentary. Additional examples may be developed and published in the future to illustrate the application of the same or other aspects of the GloBE Rules and the explanations given in the Commentary.

Chapter 2 – Examples

Article 2.1.3

Example 2.1.3 - 1

Application of Top-down Approach

1. This example illustrates the application of the top-down approach under Article 2.1.3 in a situation where the UPE is not required to apply a Qualified IIR.
2. A Co is located in Country A and is the UPE of the ABC Group. A Co directly owns B Co 1 and B Co 2, both located in Country B. B Co 1 and B Co 2 each hold 50% of the Ownership Interests in C Co, which is a Constituent Entity located in Country C. The Ownership Interests of C Co are ordinary common stock that carry an equal right to profit distributions and capital. A Co, B Co 1, B Co 2 and C Co are the only Constituent Entities in the ABC Group.
3. A Co, B Co 1 and B Co 2 all have an ETR for the Fiscal Year that is above the Minimum Rate, however, C Co is an LTCE located in a Low-Tax Jurisdiction. Of the three jurisdictions, only Country B has implemented a Qualified IIR. A diagram illustrating the holding structure and location of the members of the ABC Group is set out below.

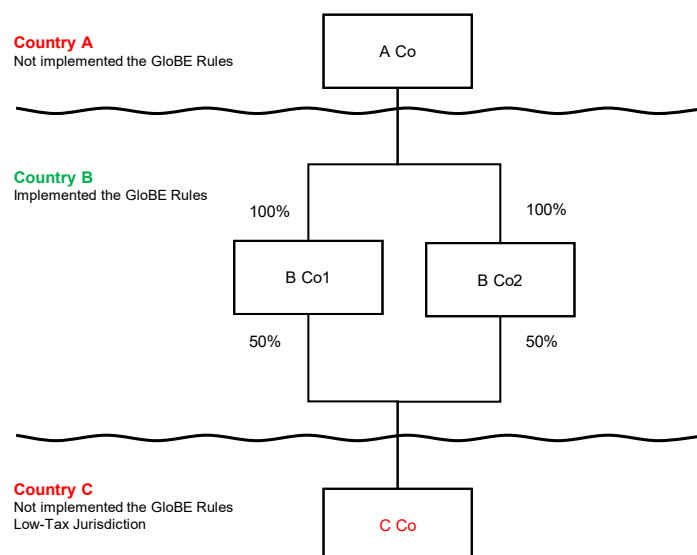

4. Country C is a Low-Tax Jurisdiction and C Co is a LTCE for the purposes of the GloBE Rules and any Top-up Tax determined for C Co under Chapter 5 will therefore be subject to charge under an applicable IIR.

5. A Co is the UPE and would have the priority to apply the IIR under Articles 2.1.1 and 2.1.3 if Country A had introduced a Qualified IIR. In this case, however, only Country B has introduced a Qualified IIR and thus, the Intermediate Parent Entities (B Co 1 and B Co 2) are required to apply the IIR in accordance with Article 2.1.2 because the conditions in Article 2.1.3(a) are not met. B Co 1 and B Co 2 must apply the IIR in accordance with Article 2.1.2 based on their Allocable Share of the Top-up Tax (50% each) of C Co. B Co 1 and B Co 2 pay the Top-tax under the IIR equal to the full amount of C Co's Top-up Tax.

Example 2.1.3 - 2

Application of Top-down Approach and Offset Mechanism

1. This example illustrates the application of the top-down approach under Article 2.1.3 in a situation where an Intermediate Parent Entity required to apply a Qualified IIR owns an Ownership Interest in another Intermediate Parent Entity that is also required to apply a Qualified IIR with respect to the same LTCE.
2. The facts are the same as in example 2.1.3 - 1, except that:
 - a. A Co directly holds 80% of the Ownership Interests in B Co 2 with the balance of B Co 2's Ownership Interests held by B Co 1; and
 - b. Rather than B Co 1 and B Co 2 each holding 50% of the Ownership Interests of C Co, B Co 1 has 10% of the Ownership Interests in C Co and B Co 2 holds 90% of the Ownership Interests.
3. A diagram illustrating the holding structure and location of the members of the ABC Group is set out below.

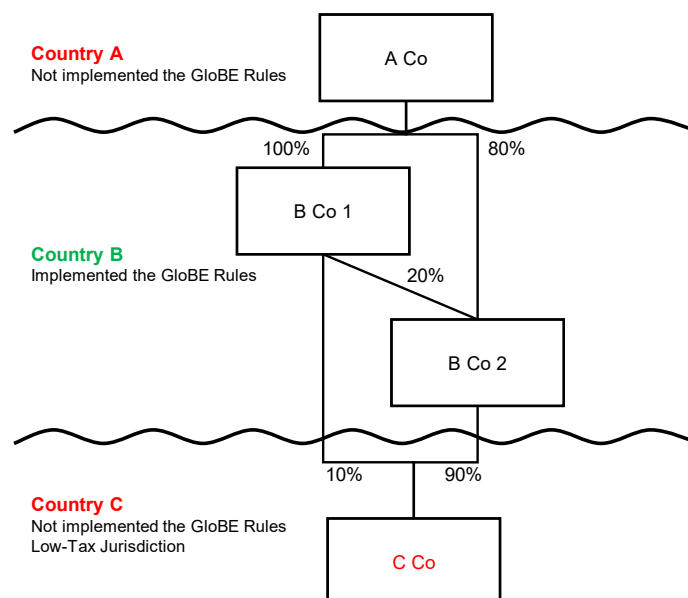

4. In this example, one of the Intermediate Parent Entities (B Co 1) that is required to apply the IIR holds some of the Ownership Interests of another Intermediate Parent Entity (B Co 2). However, Article 2.1.3(b) does not prevent the lower-tier Entity (B Co 2) from applying the IIR because B Co 1 does not own a Controlling Interest in B Co 2. Thus, both B Co 1 and B Co 2 are required to apply the IIR under Article 2.1.2 based on their Allocable Share of the Top-up Tax in accordance with Article 2.2.

5. In this case, it is assumed that B Co 2's Allocable Share of C Co's Top-up Tax is 90% (based on its direct shareholding in C Co) and that B Co 1's Allocable Share of the Top-up Tax is 28% (10% due to its direct ownership and 18% due to its indirect ownership). However, in order to avoid double taxation, Article 2.3 requires B Co 1 to reduce the Top-up Tax attributable to its indirect ownership in C Co by the amount that will be brought into charge by B Co 2.

Article 2.1.5

Example 2.1.5 - 1

Application of the IIR - POPE

1. This example illustrates the application of the split-ownership rules and the top-down approach in a situation where the UPE and POPE are required to apply a Qualified IIR with respect to the same LTCE.
2. A Co is located in Country A and is the UPE of the ABCD Group. A Co owns the Controlling Interests in three Constituent Entities: B Co, C Co and D Co, respectively located in Countries B, C and D. A Co owns 60% of the Ownership Interests in B Co, while the remaining 40% are held by third parties. B Co, in turn, wholly owns C Co and C Co wholly owns D Co. The Ownership Interest of B Co, C Co, and D Co are ordinary common stock that carry an equal right to profit distributions and capital. A diagram illustrating the holding structure and location of the members of the ABCD Group is set out below.

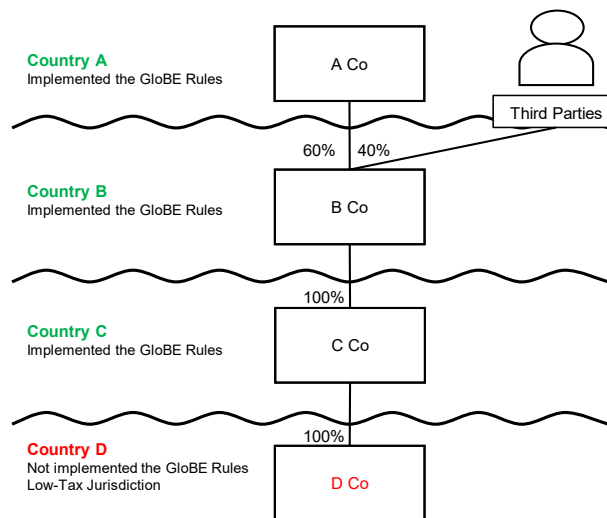

3. D Co is located in a Low-Tax Jurisdiction for the purposes of the GloBE Rules and therefore any Top-up Tax determined for D Co under Chapter 5 will be subject to charge under an applicable IIR.
4. In accordance with Article 10.1, a POPE is a Constituent Entity that: (a) owns (directly or indirectly) an Ownership Interest in another Constituent Entity of the same MNE Group; and (b) more than 20% of its Ownership Interests (in its profits) are held directly or indirectly by persons that are not Constituent Entities of the MNE Group. The indirect ownership test does not consider the Ownership Interests owned by non-Constituent Entities through the UPE. B Co is a POPE because (a) it owns an Ownership Interest in C Co and (b) 40% of its Ownership Interests are owned by persons that are not Constituent Entities of the ABCD Group. C Co also meets the definition of a POPE because (a) it owns an Ownership Interest in D Co and (b) 40% of its Ownership Interests are owned indirectly by persons that are not Constituent Entities of the ABCD Group (through B Co). However, D Co is not a POPE because, while 40% of its Ownership Interests

are owned indirectly by person that are not Constituent Entities of the MNE Group (through B Co and C Co), D Co does not own an Ownership Interest in any Constituent Entity of the MNE Group.

5. In accordance with Article 2.1.4, a POPE is required to apply the IIR based on its Allocable Share of the Top-up Tax of the LTCE notwithstanding that the UPE or an Intermediate Parent Entity is also required to apply the IIR. Thus, both B Co and C Co would be required to apply the IIR under Article 2.1.4 because they have an Ownership Interest in D Co. However, Article 2.1.5 restricts C Co from applying the IIR because it is wholly owned by another POPE (B Co). Consequently, B Co applies the IIR in accordance with Article 2.1.4 and pays tax equal to 100% of the Top-up Tax of D Co.

6. The existence of a POPE does not preclude the UPE from also applying a Qualified IIR. However, the IIR offset mechanism in Article 2.3 requires the UPE to reduce its Allocable Share of the Top-up Tax by the portion that is brought into charge by the POPE. Accordingly, A Co is required to reduce its Allocable Share of the Top-up Tax of D Co to zero in accordance with Article 2.3.

Example 2.1.5 - 2

Application of the IIR - POPE

- This example illustrates the application of the split-ownership rules and the top-down approach under Articles 2.1.4 and 2.1.5 in a situation where two POPEs are required to apply a Qualified IIR with respect to the same LTCE.
- The facts are the same as Example 2.1.5 - 1, except that:
 - 10% of the Ownership Interest in C Co is held directly by third parties; and
 - the remaining 90% is still held by B Co.
- A diagram illustrating the holding structure and location of the members of the ABCD Group is set out below.

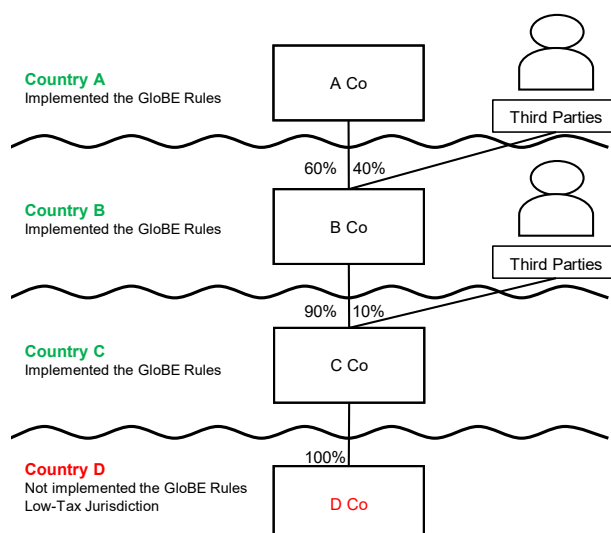

- B Co and C Co are POPEs because more than 20% of their Ownership Interests are held by persons that are not Constituent Entities of the ABCD Group. B Co is a POPE because 40% of its Ownership Interests are held directly by non-Group Members and C Co is also a POPE because 46% of its Ownership Interests are held directly (10%) or indirectly ($40\% \times 90\% = 36\%$) by third parties .
- Under this scenario, however, Article 2.1.5 does not restrict C Co from applying the IIR because it is not wholly owned by another POPE.

6. Therefore, C Co applies the IIR under Article 2.1.4 with respect to 100% of the Top-up Tax of D Co because that is its Allocable Share of the Top-up Tax. In this case, B Co is still required to apply the IIR in accordance with Article 2.1.4 (with a different Allocable Share of the Top-up Tax) and is not restricted by Article 2.1.5. However, the IIR offset mechanism of Article 2.3 would eliminate any potential double taxation due to A Co’s and B Co’s application of the IIR in respect of D Co.

Article 2.2.3

Example 2.2.3 - 1

Allocation of Top-up Tax under the IIR

1. This example illustrates the computation of the Inclusion Ratio and a Parent Entity’s Allocable Share of the Top-up Tax Amount.

2. A Co is the UPE of an MNE Group and owns 70% of the Ownership Interests in B Co, a POPE located in Country B. The remaining 30% of the Ownership Interests in B Co are owned by persons that are not Group Entities. B Co owns 20% of the Ownership Interests in C Co, an LTCE located in Country C. A Co directly owns 70% of the Ownership Interests in C Co. A person that is not a Group Entity owns the remaining 10% of the Ownership Interests in C Co. A Co owns 100% of the Ownership Interests in D Co, an LTCE located in Country D. The Ownership Interest of B Co, C Co, and D Co are ordinary common stock that carry an equal right to profit distributions and capital. A diagram illustrating the holding structure and location of the members of the MNE Group is set out below.

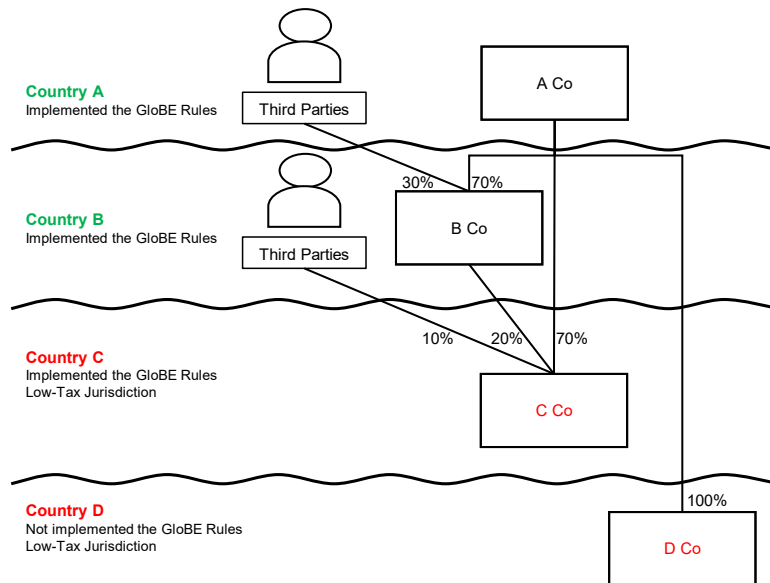

3. The Top-up Tax computed for Country C and allocated to C Co for the Fiscal Year is 1,000. The Top-up Tax computed for Country D and allocated to D Co for the Fiscal Year is 500. The Financial Accounting Net Income of C Co and D Co reflected in the Consolidated Financial Statements of A Co is 18,000 and 0, respectively. C Co’s GloBE Income is 20,000 and D Co’s GloBE Income is 35,000. The difference between C Co’s GloBE Income and the income reflected in the Consolidated Financial Statements is attributable to 2,000 of expenses that are not taken into account in computing GloBE Income or Loss. The difference between D Co’s GloBE Income and its income reflected in the Consolidated Financial Statements is attributable to the fact that all of its transactions were conducted with Group Entities located outside of Country D.

| Entity | Consolidated income | GloBE Income | Difference |
|--------|---------------------|--------------|------------|
| C Co | 18,000 | 20,000 | 2,000 |
| D Co | 0 | 35,000 | 35,000 |

4. B Co's Allocable Share of the Top-Up Tax of C Co is computed as follows:
- If B Co actually prepared Consolidated Financial Statements pursuant to UPE's financial accounting standard, it would not consolidate the income and expenses of C Co because B Co only owns a 20% Ownership Interest in C Co. However, pursuant to Article 2.2.3(a), B Co assumes that it owns a Controlling Interest in C Co such that it would be required to consolidate its income, expense, assets, liabilities and cash flows with C Co for purposes of the hypothetical Consolidated Financial Statements.
 - The first step in determining B Co's Inclusion Ratio is computing the amount of GloBE Income attributable to Ownership Interests held by "other owners" in accordance with Article 2.2.3, which includes the Ownership Interests held by A Co. Under paragraph (d), Ownership Interests held by A Co are treated as Ownership Interests held by non-Group Entities for purposes of applying the UPE's financial accounting standard for allocating income to non-Group Entities that do not have a Controlling Interest in the LTCE. In this case, 16,000 of the GloBE Income is attributed to Ownership Interests held by other owners (2,000 in relation to the 10% owned by a person that is not a Group Entity and 14,000 in relation to the 70% owned by A Co).
 - The second step is to compute B Co's "Inclusion Ratio" for C Co in accordance with Article 2.2.2. B Co's Inclusion Ratio is 20% ($= [20,000 \text{ GloBE Income} - 16,000 \text{ other owners' interest}] / 20,000 \text{ GloBE Income}$).
 - The final step is calculating B Co's Allocable Share of the Top-up Tax of C Co in accordance with Article 2.2.1. B Co's Allocable Share of the Top-up Tax is 200 ($= 1,000 \text{ Top-up Tax} \times 20\% \text{ Inclusion Ratio}$).
5. A Co's Allocable Share of the Top-Up Tax of C Co is computed as follows:
- The first step is computing the amount of GloBE Income attributable to the Ownership Interests held by "other owners" in accordance with Article 2.2.3. In this case, 3,200 of the GloBE Income is attributed to Ownership Interests held by other owners (2,000 in relation to the 10% Ownership Interests owned directly by non-Group Entities and 1,200 in relation to the 6% Ownership Interests indirectly owned by other non-Group Entities through B Co). This amount is different from the amount attributed to persons that are non-Group Entities as reflected in the Consolidated Financial Statements because Article 2.2 uses the GloBE Income and not the Financial Accounting Net Income.
 - The second step is to compute A Co's "Inclusion Ratio" for C Co in accordance with Article 2.2.2. A Co's Inclusion Ratio is 84% ($= [20,000 \text{ GloBE Income} - 3,200 \text{ other owners' interest}] / 20,000 \text{ GloBE Income}$).
 - The final step is to calculate A Co's Allocable Share of the Top-up Tax of C Co in accordance with Article 2.2 and Article 2.3. A Co first computes a tentative Allocable Share of the Top-up Tax under Article 2.2.1 of 840 ($= 1,000 \text{ Top-up Tax} \times 84\% \text{ Inclusion Ratio}$). Then, A Co reduces its Allocable Share by an amount equal to the portion that is brought to charge under the IIR applicable to B Co, or 14% ($= B \text{ Co } 20\% \times 70\%$). Thus, A Co's Allocable Share of the Top-up Tax for purposes of applying Chapter 2 is 700 ($= 840 \text{ tentative Allocable Share} - 140 \text{ offset}$).
6. Finally, A Co's Allocable Share of the Top-Up Tax of D Co is computed as follows:

- a. The first step is computing the amount of GloBE Income attributable to Ownership Interests held by “other owners” in accordance with Article 2.2.3. In this case, that amount is zero because D Co is wholly-owned by A Co.
 - b. The second step is to compute A Co’s Inclusion Ratio with respect to D Co. A Co’s Inclusion Ratio is 100% (= [35,000 GloBE Income – 0 other owners’ interest] / 35,000 GloBE Income). The fact that D Co’s income was eliminated in the actual consolidation process does not change the outcome of the hypothetical allocation because Article 2.2.3(c) requires an allocation on the basis of the GloBE Income and not the Constituent Entity’s income reflected in the Consolidated Financial Statements of A Co.
 - c. The final step is to calculate A Co’s Allocable Share of the Top-up Tax of D Co in accordance with Article 2.2.1. A Co’s Allocable Share of the Top-up Tax is 500 (= 500 Top-up Tax x 100 % Inclusion Ratio).
7. The following table illustrates each Parent Entity’s Allocable Share of the Top-up Tax of each LTCE and the Article 2.3 Offset Mechanism.

| | A Co | B Co | Non-Group | Total |
|------------------------------------|-------------|-------------|------------------|--------------|
| Allocable Share of C Co Top-up Tax | 840 | 200 | 100 | 1,140 |
| Article 2.3 Offset | (140) | - | - | (140) |
| Allocable Share of D Co Top-up Tax | 500 | - | - | 500 |
| Total Top-up Tax allocated | 1,200 | 200 | 100 | 1,500 |

Article 2.2.4

Example 2.2.4 - 1

Allocation of Top-up Tax under the IIR

1. This example illustrates the determination of the Inclusion Ratio and the Allocable Share of the Top-up Tax in a situation where some of the LTCE’s income is allocated to non-Group Entities under Article 3.5.3.
2. Reverse Hybrid Entity is a company incorporated in Country B that is treated as fiscally transparent under the tax laws of Country B but not under the tax laws of Country A. A Parent Entity of the MNE Group, located in Country A, owns 60% of the Ownership Interests of Reverse Hybrid Entity and the remaining 40% of the Ownership Interests are owned by non-Group Entities. A diagram illustrating the holding structure and location of the members of the MNE Group is set out below.

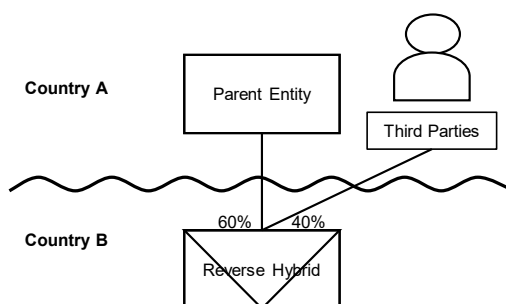

3.

4. Prior to the application of Article 3.5.1, Reverse Hybrid Entity's GloBE Income or Loss is reduced by 40%, the amount allocable to non-Group Entities. The remaining 60% of its GloBE Income or Loss is allocated to itself pursuant to Article 3.5.1(c). For purposes of determining the Parent Entity's Allocable Share of the Top-up Tax under Article 2.2, Article 2.2.4 provides that Reverse Hybrid Entity's income does not include any income allocated to non-Group Entities under Article 3.5.3. Accordingly, the Parent Entity's Inclusion Ratio for purposes of determining its Allocable Share of the Top-up Tax of Reverse Hybrid Entity is 100% after the adjustment pursuant to Article 3.5.3. In other words, because the GloBE Income allocable to the non-Group Entities has been removed from the Reverse Hybrid Entity's GloBE Income pursuant to Article 3.5.3, all of the remaining GloBE Income is attributable to the Parent Entity's Ownership Interest.

Article 2.3.2

Example 2.3.2 - 1

IIR Offset Mechanism – POPE

1. This example illustrates the application of the IIR offset mechanism in Article 2.3.2 in a situation where a UPE and a POPE apply a Qualified IIR with respect to the same LTCE.

2. A Co is the UPE of ABC Group. A Co is located in Country A that directly or indirectly owns Controlling Interests in two subsidiary companies: B Co and C Co, respectively located in Countries B and C. C Co is an LTCE located in a Low-Tax Jurisdiction. A Co, B Co and C Co are the only Constituent Entities in the ABC Group.

3. A Co has a 60% Ownership Interest in B Co while third parties own the remaining 40%. B Co, in turn, wholly owns C Co. The Ownership Interest of B Co and C Co are ordinary common stock that carry an equal right to profit distributions and capital. A diagram illustrating the holding structure and location of the members of the MNE Group is set out below.

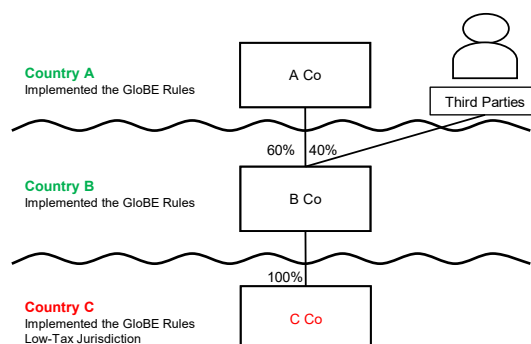

4. The Top-up Tax of C Co is EUR 10 million. B Co is a POPE because it has Ownership Interests in another Constituent Entity of the ABC Group and 40% of its Ownership Interests are held by third parties (i.e. non-group Entities). B Co is therefore required to apply the IIR in accordance with Article 2.1.4 because it is a POPE that owns an Ownership Interest in a LTCE. A Co is also required to apply the IIR in accordance with Article 2.1.1 because it is the UPE. To prevent double taxation, however, Article 2.3.1 reduces the Top-up Tax that has been allocated to A Co because it owns an Ownership Interest in an LTCE (C Co) through a POPE (B Co). The reduction of Top-up Tax is limited to “the portion” of the Top-up Tax that has been allocated to the upper-tier Parent Entity (A Co) and that “is brought into charge” by the lower-tier Intermediate Parent Entity or POPE (B Co) in accordance with Article 2.3.2.

5. Therefore, B Co is required to apply the IIR and its Allocable Share of the Top-up Tax is EUR 10 million. A Co is also required to apply the IIR but its Allocable Share of the Top-up Tax (EUR 6 million) is reduced to zero by the Top-up Tax brought into charge by B Co. A table illustrating the numerical results of this example is set out below.

| Entity | Direct Ownership Interest in C Co | Indirect Ownership Interest in C Co | Inclusion Ratio | Allocable Share of Top-up Tax | IIR offset | Final Top-up Tax Liability |
|--------|-----------------------------------|-------------------------------------|-----------------|-------------------------------|---------------|----------------------------|
| B Co | 100% | - | 1 | EUR 10 million | - | EUR 10 million |
| A Co | - | 60% (60%*100%) | 0.6 | EUR 6 million | EUR 6 million | EUR 0 |

Example 2.3.2 - 2

IIR Offset Mechanism – POPE

1. This example illustrates the application of the IIR offset mechanism in Article 2.3.2 in a situation where a UPE has a direct Ownership Interest in an LTCE and an indirect Ownership Interest in the LTCE that is owned through a POPE and both the UPE and the POPE apply a Qualified IIR with respect to the LTCE.

2. The facts are the same as Example 2.3.2 - 1, except that A Co has a 50% direct Ownership Interest in C Co while the remaining 50% is held by B Co. The Ownership Interests of B Co and C Co are ordinary common stock that carry an equal right to profit distributions and capital. A diagram illustrating the holding structure and location of the members of the MNE Group is set out below.

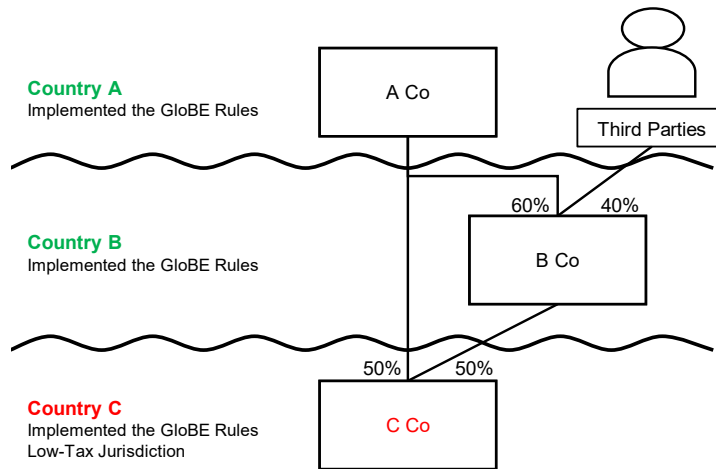

3. The Top-up Tax of C Co is EUR 10 million. B Co is required to apply the IIR because it is a POPE that owns 50% of an LTCE (C Co). A Co is also required to apply the IIR because it is a UPE that owns, directly and indirectly, 80% of an LTCE (C Co). A Co's Allocable Share of Top-up Tax, however, is reduced by an amount equal to the portion that is brought into charge by the lower-tier Parent Entity (B Co). A table illustrating the numerical results of this example is set out below.

| Entity | Direct Ownership Interest in C Co | Indirect Ownership Interest in C Co | Inclusion Ratio | Allocable Share of Top-up Tax | IIR offset | Final Top-up Tax liability |
|--------|-----------------------------------|-------------------------------------|-----------------|-------------------------------|---------------|----------------------------|
| B Co | 50% | - | 0.5 | EUR 5 million | - | EUR 5 million |
| A Co | 50% | 30% (60%*50%) | 0.8 | EUR 8 million | EUR 3 million | EUR 5 million |

Example 2.3.2 – 3

IIR Offset Mechanism – Intermediate Parent Entity

1. This example illustrates the application of the IIR offset mechanism in Article 2.3.2 in a situation where two Intermediate Parent Entities apply a Qualified IIR with respect to the same LTCE.

2. A Co is the UPE of ABCD Group. A Co is a company located in Country A that owns Controlling Interests in three subsidiary companies: B Co, C Co and D Co, respectively located in Countries B, C and D. D Co is an LTCE located in a Low-Tax Jurisdiction. A Co, B Co, C Co and D Co are the only Constituent Entities in the ABCD Group. Only Countries B and C have implemented the GloBE Rules.

3. A Co has a 100% Ownership Interest in B Co and a 60% Ownership Interest in C Co. B Co has the remaining 40% Ownership Interest in C Co, which is not a Controlling Interest for the purposes of this example. C Co, in turn, has a 100% Ownership Interest in D Co. The Ownership Interests of C Co are ordinary common stock that carry an equal right to profit distributions and capital. A diagram illustrating the holding structure and location of the members of the MNE Group is set out below.

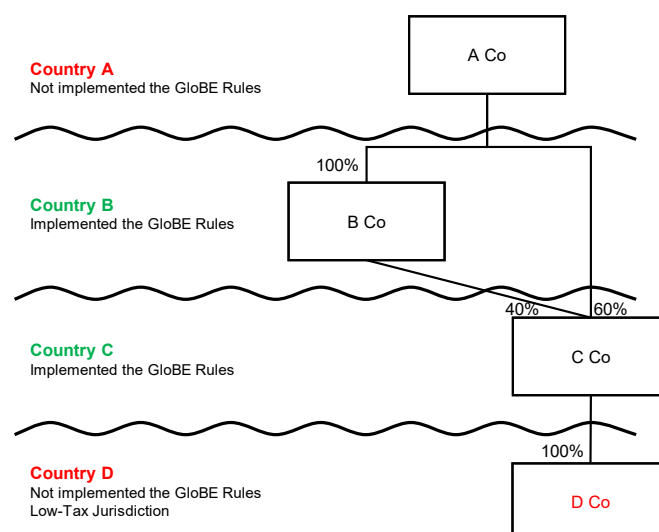

4. The Top-up Tax of D Co is EUR 10 million. The UPE (A Co) is not required to apply the IIR as Country A has not implemented the GloBE Rules.

5. C Co is an Intermediate Parent Entity and is therefore required to apply the IIR in accordance with Article 2.1.2 because it owns an Ownership Interest in an LTCE (D Co). C Co's obligation to apply the IIR

is not switched-off under Article 2.1.3 because the Parent Entity holding its Controlling Interests (A Co) is not required to apply the IIR.

6. B Co is also required to apply the IIR because it is an Intermediate Parent Entity that owns 40% of an LTCE (D Co) and its Controlling Interests are not held by a Parent Entity that is required to apply the IIR (A Co is not required to apply the IIR). B Co's Allocable Share of the Top-up Tax, however, is reduced by the amount that is equal to the portion brought into charge by the lower-tier Parent Entity (C Co) through which its Ownership Interest in D Co is held. A table illustrating the numerical results of this example is set out below.

| Entity | Direct Ownership Interest in D Co | Indirect Ownership Interest in D Co | Inclusion Ratio | Allocable Share of Top-up Tax | IIR off-set | Final Top-up Tax liability |
|--------|-----------------------------------|-------------------------------------|-----------------|-------------------------------|---------------|----------------------------|
| A Co | - | 100% (60%+40%) | - | - | - | |
| B Co | - | 40% | 0.4 | EUR 4 million | EUR 4 million | EUR 0 |
| C Co | 100% | - | 1 | EUR 10 million | - | EUR 10 million |

Article 2.4.1

Example 2.4.1 - 1

Application of the UTPR – Additional Cash Tax Expense (reduction of loss carry-forward)

1. This example illustrates how to assess whether Constituent Entities located in a UTPR Jurisdiction have an additional cash tax expense equal to the UTPR Top-up Tax Amount allocated to that jurisdiction for purposes of applying Article 2.4.1. Assessing whether Constituent Entities have had an additional cash tax expense equal to that UTPR Top-up Tax Amount may also be relevant for the purposes of applying Article 2.4.2 (availability of the carry-forward mechanism) and 2.6.3 (effect on the UTPR Percentage of a UTPR Jurisdiction).

2. Assume a Constituent Entity in a UTPR Jurisdiction earns revenue of EUR 200 and deductible expenses of EUR 300 (loss of EUR 100) in Year 1 and revenue of EUR 200 and deductible expenses of EUR 100 (profit of EUR 100) in Year 2. Assume the jurisdiction where the Constituent Entity is located allows losses to be carried forward indefinitely. Assume that the UTPR Top-up Tax Amount allocated to that jurisdiction is EUR 60 for Year 1, that the jurisdiction has a CIT rate of 20% and that there are no other Constituent Entities in that jurisdiction.

3. The additional cash tax expense is in addition to the amount of additional tax that the Constituent Entities would otherwise have been paid under the ordinary domestic rules for calculating their taxable income and tax liability. Therefore, the additional cash tax expense is determined by comparing the amount of tax that is due after the UTPR adjustment is made with the amount of tax that would have been paid under the ordinary domestic rules for calculating taxable income.

4. The jurisdiction denies EUR 300 of deductions (= 60 / 20%) under its UTPR in order to produce an additional tax expense of EUR 60, equal to the UTPR Top-up Tax Amount. In Year 1, the denial of a deduction for EUR 300 of expenses results in the elimination of the loss carry-forward of EUR 100 and in a profit of EUR 200. On the profit of EUR 200, the Constituent Entity is subject to EUR 40 of tax in respect of Year 1, whereas it would not have been liable for any tax in the absence of a UTPR adjustment. The EUR 40 of additional tax is the additional cash tax expense incurred in respect of Year 1, and the full additional cash tax expense (60) is not paid in Year 1. The EUR 40 of additional tax is lower than the EUR

60 of UTPR Top-up Tax Amount allocated to this jurisdiction, but an additional cash tax expense may arise in respect of a future year because of the elimination of the loss carry-forward.

5. In this example, the UTPR adjustment made in respect of Year 1 will result in another additional cash tax expense in Year 2. Because the UTPR adjustment has eliminated the loss carry-forward of EUR 100, the Constituent Entity will have an additional cash tax expense of EUR 20 on the profits generated in Year 2. If the loss carry-forward of EUR 100 was not eliminated in Year 1 as a result of the UTPR adjustment, it would have offset the taxable income in Year 2 and resulted in no income tax liability in Year 2 absent the application of the UTPR.

6. The following table summarises the income tax liability of the Constituent Entity in the UTPR Jurisdiction before the UTPR adjustment.

| Before UTPR adjustment | Year 1 | Year 2 |
|--|---------------|---------------|
| <i>Revenue</i> | 200 | 200 |
| <i>Deductible Expenses</i> | (300) | (100) |
| <i>Profit or loss (before UTPR adjustment)</i> | (100) | 100 |
| <i>Loss carry-forward generated or (used) (before UTPR adjustment)</i> | 100 | (100) |
| <i>Loss carry-forward balance (before UTPR adjustment)</i> | 100 | 0 |
| <i>Tax due in the jurisdiction (before UTPR adjustment)</i> | 0 | 0 |

7. The following table summarises the income tax liability of the Constituent Entity in the UTPR Jurisdiction after the UTPR adjustment.

| After UTPR adjustment | Year 1 | Year 2 |
|---|---------------|---------------|
| <i>Revenue</i> | 200 | 200 |
| <i>Deductible Expenses</i> | (300) | (100) |
| <i>UTPR Adjustment (denial of deduction)</i> | 300 | - |
| <i>Profit or loss (after UTPR adjustment)</i> | 200 | 100 |
| <i>Loss carry-forward generated or (used) (after UTPR adjustment)</i> | 0 | 0 |
| <i>Loss carry-forward balance (after UTPR adjustment)</i> | 0 | 0 |
| <i>Tax due in the jurisdiction (after UTPR adjustment)</i> | 40 | 20 |

8. The following table illustrates the computations that are made to assess the additional cash tax expense that the Constituent Entity had in respect of Year 1 and Year 2.

| Computation of the additional cash tax expense | Year 1 | Year 2 |
|---|---------------|---------------|
| <i>[A] Tax due in the jurisdiction (before UTPR adjustment)</i> | 0 | 0 |
| <i>[B] Tax due in the jurisdiction (after UTPR adjustment)</i> | 40 | 20 |
| <i>[C] Additional cash tax expense, where [C] = [B] – [A]</i> | 40 | 20 |

2. As illustrated in this example, a reduction to loss carry-forward does not result in additional cash tax expense until corresponding income has arisen in a subsequent period. On this basis, the additional

cash tax expense incurred by the Constituent Entity amounts to EUR 30 in respect of Year 1 and EUR 20 in respect of Year 2. Therefore, this Constituent Entity has an additional cash tax expense of EUR 60 over the period.

Article 2.4.2

Example 2.4.2 - 1

Application of the UTPR – Additional Cash Tax Expense (no loss carry-forward)

1. This example illustrates a situation where the carry-forward mechanism provided under Article 2.4.2 is necessary for the Constituent Entities located in a UTPR Jurisdiction to have an additional cash tax expense equal to the UTPR Top-up Tax Amount allocated to that jurisdiction for the purposes of applying Article 2.4.1.
2. In Example 2.4.1 - 1, the application of the UTPR in Year 1 eliminates the loss that can be carried forward to Year 2 and results in an additional cash tax expense over the two-year period that equals the UTPR Top-up Tax Amount. Therefore, no additional UTPR adjustment is needed in Year 2.
3. The facts are the same as in Example 2.4.1 - 1, except that the UTPR jurisdiction does not allow the carry forward of losses in the computation of taxable income.
4. The following table summarises the income tax liability of the Constituent Entity in the UTPR Jurisdiction before the UTPR adjustment.

| Before UTPR adjustment | Year 1 | Year 2 |
|--|---------------|---------------|
| <i>Revenue</i> | 200 | 200 |
| <i>Deductible Expenses</i> | (300) | (100) |
| <i>Profit or loss (before UTPR adjustment)</i> | (100) | 100 |
| <i>Loss carry-forward (before UTPR adjustment) – not available</i> | 0 | 0 |
| <i>Tax due in the jurisdiction (before UTPR adjustment)</i> | 0 | 20 |

5. The following table summarises the income tax liability of the Constituent Entity in the UTPR Jurisdiction after the UTPR adjustment made in respect of Year 1.

| After UTPR adjustment made in Year 1 | Year 1 | Year 2 |
|---|---------------|---------------|
| <i>Revenue</i> | 200 | 200 |
| <i>Deductible Expenses</i> | (300) | (100) |
| <i>UTPR Adjustment (denial of deduction)</i> | 300 | - |
| <i>Profit or loss (after UTPR adjustment)</i> | 200 | 100 |
| <i>Loss carry-forward (after UTPR adjustment) – not available</i> | 0 | 0 |
| <i>Tax due in the jurisdiction (after UTPR adjustment)</i> | 40 | 20 |

6. In this example, the additional cash tax expense incurred by the Constituent Entity amounts to EUR 40 in respect of Year 1 and EUR 0 in respect of Year 2 unless an additional adjustment is made

under Article 2.4.2 (see below). There is no additional cash tax expense in Year 2 that results from the UTPR adjustment made in Year 1.

7. Therefore, to impose an additional cash tax expense under the UTPR in Year 2, the UTPR Jurisdiction will need to deny another EUR 100 of deductions in Year 2 to increase the profit to EUR 200 (thereby imposing an additional EUR 20 of tax by virtue of the application of the UTPR).

8. The following table summarises the income tax liability of the Constituent Entity in the UTPR Jurisdiction after the UTPR adjustment made in respect of Year 1 and the additional adjustment made in respect of Year 2.

| After UTPR adjustment in Year 1 and 2 | Year 1 | Year 2 |
|---|---------------|---------------|
| <i>Revenue</i> | 200 | 200 |
| <i>Deductible Expenses</i> | (300) | (100) |
| <i>UTPR Adjustment (denial of deduction)</i> | 300 | 100 |
| <i>Profit or loss (after UTPR adjustment)</i> | 200 | 200 |
| <i>Loss carry-forward (after UTPR adjustment) – not available</i> | 0 | 0 |
| <i>Tax due in the jurisdiction (after UTPR adjustment)</i> | 40 | 40 |

9. The following table illustrates the computations that are made to assess the additional cash tax expense that the Constituent Entity had in respect of Year 1 and Year 2.

| Computation of the additional cash tax expense | Year 1 | Year 2 |
|---|---------------|---------------|
| <i>[A] Tax due in the jurisdiction (before UTPR adjustment)</i> | 0 | 20 |
| <i>[B] Tax due in the jurisdiction (after UTPR adjustment)</i> | 40 | 40 |
| <i>[C] Additional cash tax expense, where [C] = [B] – [A]</i> | 40 | 20 |

10. In this example, the additional cash tax expense incurred by the Constituent Entity amounts to EUR 30 in respect of Year 1 and EUR 20 in respect of Year 2. Therefore, this Constituent Entity has an additional cash tax expense of EUR 50 over the period, but, unlike in Example 2.4.1-1, an additional UTPR adjustment was necessary in respect of Year 2 to achieve this outcome. This additional adjustment is made under Article 2.4.2.

Article 2.5.3

Example 2.5.3 – 1

UTPR Top-up Tax Amount

1. This example illustrates how to compute the UTPR Top-up Tax Amount under Article 2.5.3.
2. Assume A Co is the UPE of the ABC Group. A Co is located in Jurisdiction A. A Co directly owns 100% of B Co, 55% of C Co and 100% of D Co, respectively located in Jurisdictions B, C and D. Assume B Co has a 40% Ownership interest in C Co, and that the remaining 5% ownership interests of C Co are held by minority shareholders. A diagram illustrating the holding structure and location of the members of the ABC Group is set out below.

3. Assume C Co is a LTCE and Jurisdictions A and C have not implemented the GloBE Rules whereas Jurisdictions B and D both have a Qualified IIR and a Qualified UTPR. Assume the Top-up Tax of C Co is EUR 100.

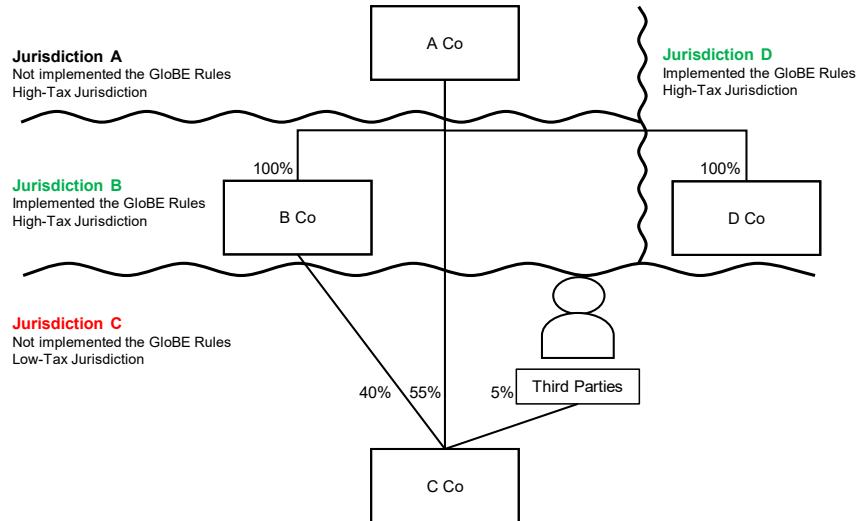

4. A Co is not required to apply a Qualified IIR. B Co's allocable share of the Top-up Tax of C Co equals 40%. Therefore, as provided under Article 2.1.2, B Co is required to apply a Qualified IIR with respect to 40% of the Top-up Tax of C Co. B Co is liable for a Top-up Tax of EUR 40.

5. A Co's Ownership Interest in C Co equals to 95% in total (40% indirectly held via B Co and 55% directly held). Therefore, not all of A Co's Ownership Interest in C Co are held by a Parent Entity that is required to apply a Qualified IIR with respect to C Co and Article 2.5.3 applies respectively.

6. Article 2.5.3 provides that the Top-up Tax of EUR 100 of C Co is reduced by the amount of B Co's allocable share of C Co's Top-up Tax (EUR 40) to compute the UTPR Top-up Tax Amount that is allocated under the UTPR. In this example, the UTPR Top-up Tax Amount is EUR 60 (= 100 – 40).

Article 2.6.4

Example 2.6.4 – 1

Allocation of Top-up Tax for the UTPR

1. This example illustrates the effect of Article 2.6.4 on the UTPR Percentages of the UTPR Jurisdictions.

2. The fact pattern is similar to the one presented in Example 2.5.3 – 1 but B Co does not own any Ownership Interest in C Co and A Co holds its Ownership Interest in C Co directly. A diagram illustrating the holding structure and location of the members of the ABC Group is set out further below.

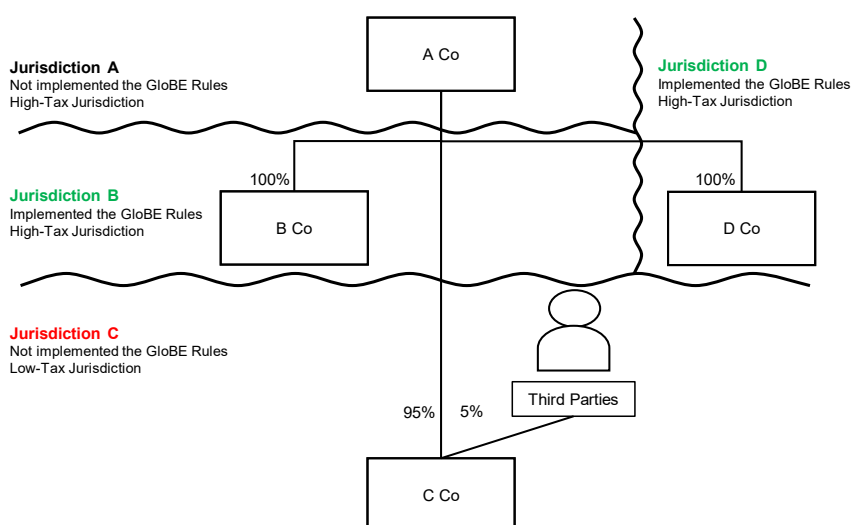

3. No Constituent Entity is required to apply a Qualified IIR with respect to the Top-up Tax of C Co because Jurisdiction A has not implemented the GloBE Rules and B Co and D Co do not have Ownership Interests in C Co. Therefore, the total amount of Top-up Tax is allocated under the UTPR.

4. Assume the UTPR Top-up Tax Amount in respect of C Co is EUR 100 for each of Fiscal Years 1 to 4 and that the UTPR Percentages of Jurisdictions B and D are 50% each over the same period based on the formula under Article 2.6.1.

5. For Fiscal Year 1, Jurisdiction B and D are each allocated an amount of Top-up Tax of EUR 50. Assume that Jurisdiction B is not able to collect the whole amount of EUR 50 for the taxable year in which Fiscal Year 1 ends. Article 2.6.3 provides that Jurisdiction B's UTPR Percentage is deemed to be zero for Year 2 (and following Years) as long as the UTPR Top-Up Tax Amount of EUR 50 allocated to Jurisdiction B in Year 1 has not resulted in B Co having an equivalent additional cash tax expense. This means that no more UTPR Top-up Tax Amount is allocated to Jurisdiction B until it has been able to impose the relevant Tax.

6. In Fiscal Year 2, Jurisdiction B has a UTPR percentage of zero. As a consequence, the whole UTPR Top-up Tax calculated for Fiscal Year 2 (EUR 100) is allocated to Jurisdiction D. Assume that Jurisdiction B is again not able to collect the whole amount of UTPR Top-up Tax of EUR 50 (allocated in respect of Fiscal Year 1) for the taxable year in which Fiscal Year 2 ends. Further, Jurisdiction D is also not able to collect the whole amount of EUR 100 (allocated in respect of Fiscal Year 2) for the taxable year in which Fiscal Year 2 ends. As provided in Article 2.6.3, both Jurisdictions B and D would have a UTPR percentage of zero for Fiscal Year 3.

7. However, Article 2.6.4 stipulates that Article 2.6.3 would not apply when it would result in all UTPR Jurisdictions' UTPR percentages being reduced to zero. Pursuant to Article 2.4.2, in Fiscal Year 3, the Total UTPR Top-up Tax Amount of EUR 100 is therefore allocated to Jurisdictions B and D in respect of their UTPR Percentage based on the formula under Article 2.6.1 (50%/50%) without the application of Article 2.6.3. An amount of EUR 50 of Top-up Tax is added to the other UTPR Top-up Tax Amounts that are still to be collected by each Jurisdiction.

8. Finally, assume that all remaining UTPR Top-up Tax Amounts are collected in both Jurisdictions for the taxable year in which Fiscal Year 3 ends. In Fiscal Year 4, the UTPR Top-up Tax Amount of 100 is allocated to Jurisdictions B and D based on their respective UTPR Percentages determined using the formula in Article 2.6.1.

9. The following table summarises the amount of UTPR Top-up Tax allocated to each Jurisdiction under this example.

| Year | UTPR Top-up Tax Amount | Allocation Jurisdiction B | Allocation Jurisdiction D |
|------|------------------------|------------------------------------|--------------------------------------|
| 1 | EUR 100 | EUR 50 (UTPR Percentage of 50%) | EUR 50 (UTPR Percentage of 50%) |
| 2 | EUR 100 | EUR 0 (UTPR Percentage of 0%) | EUR 100 (UTPR Percentage of 100%) |
| 3 | EUR 100 | EUR 50 (UTPR Percentage of 50%) | EUR 50 (UTPR Percentage of 50%) |
| 4 | EUR 100 | EUR 50 (UTPR Percentage of 50%) | EUR 50 (UTPR Percentage of 50%) |

Chapter 3 – Examples

Article 3.2.1(b)

Example 3.2.1(b) - 1

Excluded Dividend and Short-term Portfolio Shareholding

1. This example illustrates how to test the period during which a Portfolio Shareholding was held.
2. Assume A Co is a Constituent Entity of an MNE Group that is subject to the GloBE Rules. B Co is unrelated to A Co. B Co has 10,000 ordinary shares on issue that carry an equal right to profit distributions and capital. A Co acquires 200 common shares in B Co on 1 July in Year 1 and acquires an additional 100 common shares in B Co on 31 March in Year 2. B Co has only one class of shares and distributes a dividend of EUR 0.10 per share on 31 December of Year 2. A time line showing the period A Co held the two tranches of B Co shares and the receipt of the dividend is set out below.

| Year 1 | | | | Year 2 | | | |
|------------|-------------|-------------------------------------|-------------|---------------------------------------|-------------|--------------|-----------------------------------|
| Jan.-March | April -June | July – Sept. | Oct. – Dec. | Jan.-March | April -June | July – Sept. | Oct. – Dec. |
| | | 200 Shares | | | | | |
| | | | | | 100 Shares | | |
| | | 1 July Acquisition 200 | | 31 March Acquisition 100 | | | 31 December Dividend 30 |

3. A Co is a member of an MNE Group that holds less than 10% of the shares in B Co. Therefore, A Co holds a Portfolio Shareholding in B Co at the date the dividend is paid. One hundred of these shares are treated as a Short-term Portfolio Shareholding under the GloBE Rules because A Co has held those shares for less than 12 months at the dividend date. The dividends received on those shares (10 = 100 shares x 0.10) will be taken into account in calculating A Co's GloBE income and only 20 of the dividends received by A Co in respect of the remaining 200 shares will be treated as an Excluded Dividend under Article 3.2.1(b) of the GloBE Rules.

Example 3.2.1(b) - 2

Excluded Dividend and Short-term Portfolio Shareholding

1. The facts are the same as in Example 3.2.1(b) - 1, except that A Co disposes of 40 B Co shares on 30 September in Year 2. In accordance with the Commentary to Article 3.2.1, the sale of B Co shares is deemed to be a sale of those shares of the same class of shares that were most recently acquired by A Co. Therefore, A Co is treated as having disposed the B Co common shares that were acquired on 31 March in Year 2. B Co distributes a dividend of EUR 0.10 per share on 31 December of Year 2. A timeline showing the period A Co held the B Co shares and the receipt of the dividend is set out below.

| Year 1 | | | | Year 2 | | | |
|-------------|-------------|-------------------------------------|-----------|---------------------------------------|-------------|--------------------------------|-----------------------------------|
| Jan.- March | April -June | July – Sept. | Oct.-Dec. | Jan.-March | April -June | July – Sept. | Oct. – Dec. |
| | | 200 Shares | | | | | |
| | | | | | 60 Shares | | |
| | | | | | 40 Shares | | |
| | | 1 July Acquisition 200 | | 31 March Acquisition 100 | | 30 September Sale 40 | 31 December Dividend 26 |

2. At the date of the distribution, 60 of the 260 shares that are held are treated as a Short-term Portfolio Shareholding under the GloBE Rules because A Co has held those 60 shares for less than 12 months at the dividend date. The dividend received on those shares ($6 = 60 \text{ shares} \times 0.10$) will be taken into account in calculating A Co's GloBE income and only 20 of the dividends received by A Co in respect of the remaining 200 shares will be treated as an Excluded Dividend under Article 3.2.1 of the GloBE Rules.

Example 3.2.1(b) - 3

Excluded Dividend and Short-term Portfolio Shareholding

1. The facts are the same as Example 3.2.1(b) - 1 but assume that A Co disposes of 50 shares on 31 December of Year 1. In accordance with the Commentary to Article 3.2.1, the sale of B Co shares is deemed to be a sale of those shares that were most recently acquired by A Co. In this case A Co is treated as having disposed the B Co shares that were acquired on 1 July in Year 1. B Co distributes a dividend of EUR 0.10 per share on 31 December of Year 2. A timeline showing the period A Co held the B Co shares and the receipt of the dividend is set out below.

| Year 1 | | | | Year 2 | | | |
|-------------|--------------|----------------------------------|-------------------------------|------------------------------------|--------------|-------------|-------------|
| Jan.- March | April - June | July – Sept. | Oct. – Dec. | Jan. - March | April - June | July – Sept | Oct. – Dec. |
| | | 150 Shares | | | | | |
| | | 50 Shares | | | 100 Shares | | |
| | | 1 July Acquisition 200 | 31 December Sale 50 | 31 March Acquisition 100 | | | Dividend 25 |

2. At the date of the distribution, 100 of these shares are treated as a Short-term Portfolio Shareholding under the GloBE Rules because A Co has held those shares for less than 12 months as at the dividend date. The dividend received on these shares ($10 = 100 \text{ shares} \times 0.10$) will be taken into account in calculating A Co's GloBE income and only 15 of the dividends received by A Co in respect of the remaining 150 shares will be treated as an Excluded Dividend under Article 3.2.1 of the GloBE Rules.

Article 3.2.1(f)

Example 3.2.1(f) - 1

Asymmetric Foreign Currency Gains or Losses

1. A Co, located in Country A, is member of an MNE Group that is subject to the GloBE Rules. A Co has an accounting and tax reporting period that corresponds to the calendar year. A Co uses Euros for its tax functional currency and US Dollars for its accounting functional currency. At the start of Year 1, A Co holds a non-interest bearing bond with a face value of \$1,000. At the beginning of the year the EUR€ : US\$ exchange rate is €1:\$1, however by the end of the year the Euro has strengthened against the US\$ and the exchange rate is €1:\$1.25. The fall in the value of the bond in euro terms ($-\text{€}200 = [\text{€}1,000 / 1.25] - \text{€}1,000$) is taken into account in Year 1 as a deduction for the purposes of calculating A Co's taxable income under Country A law. However there is no change to A Co's accounting income because the bond is denominated in the same currency as the financial accounts.

2. The table below illustrates the effect of the movement in the exchange rate in Year 1. The table on the left shows A Co's profit and ETR for local tax purposes (calculated in Euros) while the table on the right shows the same calculations for accounting purposes (calculated in dollars). Other income and Country A tax are converted based on the year-end exchange rate of €1:\$1.25.

| Tax Functional Currency (Euros) | | Accounting Functional Currency (Dollars) | |
|---------------------------------|-------|--|-----|
| Other income | 500 | Other income | 625 |
| Foreign currency gain (loss) | (200) | Foreign currency gain (loss) | - |
| Total profit | 300 | Total profit | 625 |
| Country A Tax | 60 | Country A Tax | 75 |
| ETR | 20% | | 12% |

3. In this case, the strengthening of the Euro results in a decrease in profit for A Co in EUR terms (and a corresponding decrease in tax expense), however the financial accounts do not show a foreign currency loss on the bond because both the bond and the accounts are denominated in the same currency. Accordingly, while A Co's ETR in its tax functional currency is 20%, the ETR is 12% (i.e. $75/625$) in its financial accounting functional currency.

4. The foreign currency loss that arises for tax purposes is attributable to fluctuations in the exchange rate between its accounting and tax functional currency. Accordingly, this loss falls within paragraph (a) of the definition of Asymmetric Foreign Currency Gains or Losses. The amount of the loss that is recognised for tax purposes must be translated into dollars at the relevant exchange rate (€1:\$1.25) and then included as a negative adjustment to the Financial Accounting Net Income or Loss of A Co. The table below shows the effect of including the Asymmetric Foreign Currency Loss in the GloBE ETR calculation.

| Accounting Functional Currency (Dollars) | |
|--|-------|
| Other income | 625 |
| Asymmetric Foreign Currency Gain (Loss) Adj. | (250) |
| Total profit | 375 |
| Country A Tax | (75) |
| ETR | 20% |

Example 3.2.1(f) - 2

Asymmetric Foreign Currency Gains or Losses

1. A Co, located in Country A, is member of an MNE Group that is subject to the GloBE Rules. A Co has an accounting and tax reporting period that corresponds to the calendar year. A Co uses Euros for its tax functional currency and US Dollars for its accounting functional currency. At the start of Year 1, A Co enters into a loan agreement denominated in Euros and at the end of Year 1 it accrues EUR 500 of interest expense that translates to \$500 interest expense in the Consolidated Financial Statements because the EUR€ : US\$ exchange rate is €1:\$1 for Year 1.

2. In Year 2, A Co pays EUR 500 of interest expense accrued at the end of Year 1, which translates to \$625 in the financial accounts because the Euro has strengthened against the US\$ and the exchange rate is now €1:\$1.25. The difference between the amount of interest expense accrued (\$500) and the amount paid (\$625), or \$125, is reflected as a foreign currency loss or additional interest expense in the Consolidated Financial Statements. However, that difference does not result in any tax gain or loss because the loan and the interest expense are denominated in Euros, which is the tax functional currency.

3. The table below illustrates the effect of the movement in the exchange rate between Year 1 and Year 2. The table on the left shows A Co's profit and ETR for local tax purposes (calculated in Euros) in Year 2 while the table on the right shows the same calculations for accounting purposes (calculated in dollars). Other Income and Tax are converted based on the year-end exchange rate of €1:\$1.25.

| Tax Functional Currency (Euros) | | Accounting Functional Currency (Dollars) | |
|---------------------------------|-------|--|-------|
| Other income | 1,000 | Other income | 1,250 |
| Foreign currency gain (loss) | - | Foreign currency gain (loss) | (125) |
| Total profit | 1,000 | Total profit | 1,125 |
| Tax | (200) | Tax | (250) |
| ETR | 20% | | 22.2% |

4. In this case, the strengthening of the Euro results in a foreign currency loss or an increase of interest payable for A Co in dollar terms but the tax accounts do not show a foreign currency loss for A Co on the interest payable because both the interest payable and the tax accounts are denominated in the same currency. Accordingly, while A Co's ETR when calculated based on its tax accounts is 20%, the ETR is 22.2% (i.e. 250/1,125) when calculated based on its financial accounts.

5. The foreign currency loss that arises for accounting purposes is attributable to fluctuations in the exchange rate between its tax and accounting functional currency. Accordingly, this loss falls within paragraph (b) of the definition of Asymmetric Foreign Currency Gains or Losses. The amount of the loss that is recognised for accounting purposes must be included as a positive adjustment to the Financial Accounting Net Income or Loss of A Co. The table below shows the effect of including the Asymmetric Foreign Currency Loss in the GloBE Income or Loss and ETR calculation.

| Accounting Functional Currency (Dollars) | |
|--|-------|
| Other income | 1250 |
| Foreign Currency Gain (Loss) | (125) |
| Asymmetric Foreign Currency Gain (Loss) Adj. | 125 |
| Total profit | 1,250 |
| Country C Tax | (250) |
| ETR | 20% |

Example 3.2.1(f) - 3

Asymmetric Foreign Currency Gains or Losses

1. A Co, located in Country A, is member of an MNE Group that is subject to the GloBE Rules. A Co has an accounting and tax reporting period that corresponds to the calendar year. A Co uses Euros for its tax functional currency and US Dollars for its accounting functional currency. In Year 1, the GBP£ : EUR€ exchange rate is £1:€1.1, the GBP£ : US\$ exchange rate is £1:\$1.8, and the US\$: EUR€ exchange rate is \$1:€0.61. In Year 1, A Co sells merchandise on account for £100 and accrues a receivable of €110 for local tax purposes and a receivable of \$180 in the financial accounts.

2. In Year 2, A Co receives £100 in respect of the receivable recorded in Year 1, which translates to €121 and \$198 because the British Pound Sterling has strengthened: (i) against the Euro so that the exchange rate is now £1:€1.21; and (ii) against the US Dollar so that the exchange rate is now £1:\$1.98. (In Year 2, the US\$: EUR€ exchange rate remains \$1:€0.61.)

3. The strengthening of the British Pound Sterling results in a €11 (= 121 – 110) gain for tax purposes because A Co received British Pounds Sterling worth €121 in respect of a receivable that was recorded at €110 in the tax accounts. Furthermore, the strengthening results in a \$18 (= 198 - 180) gain for accounting purposes because A Co received British Pounds Sterling worth \$198 in respect of a receivable that was recorded at \$180 in the financial accounts. The gain in euro terms, however, is not taken into account for the purposes of calculating A Co's taxable income under Country A law.

4. The table below illustrates the effect of the movement in the exchange rate between Year 1 and Year 2. The table on the left shows A Co's profit and ETR for local tax purposes (calculated in Euros) in Year 2 while the table on the right shows the same calculations for accounting purposes (calculated in Dollars). Other Income and Tax are converted based on the year-end exchange rates of £1:€1.21 and £1:\$1.98.

| Tax Functional Currency (Euros) | | Accounting Functional Currency (Dollars) | |
|---------------------------------|-----|--|-----|
| Other income | 200 | Other income | 328 |
| Foreign currency gain (loss) | - | Foreign currency gain (loss) | 18 |
| Total profit | 200 | Total profit | 346 |
| Tax | 30 | Tax | 49 |
| ETR | 15% | ETR | 14% |

5. In this case, the strengthening of the British Pound Sterling results in an increase of profit for A Co in dollar terms. The foreign currency gain that arises for accounting purposes is attributable to fluctuations in the exchange rate between a third currency (GBP) and the accounting functional currency of A Co. Accordingly, this gain falls within paragraph (c) of the definition of Asymmetric Foreign Currency Gains or Losses. Therefore, the amount of the gain that is recognised for accounting purposes must be included as a negative adjustment to the Financial Accounting Net Income or Loss of A Co.

6. The foreign currency gain that is attributable to fluctuations in the exchange rate between a third currency (GBP) and the tax functional currency of A Co falls within paragraph (d) of the definition of Asymmetric Foreign Currency Gains or Losses. Paragraph (d) requires an adjustment to the Financial Accounting Net Income or Loss when there is a gain or loss attributable to such fluctuations irrespective of whether such gain or loss is included in the taxable income of A Co. Accordingly, the amount of the gain in respect of the tax functional currency must be translated into the accounting functional currency and included as a positive adjustment to the Financial Accounting Net Income or Loss of A Co. The table below shows the effect of including the adjustments under paragraphs (c) and (d) of the Asymmetric Foreign Currency Gain adjustments under paragraphs (c) and (d) in the GloBE ETR calculation.

| Accounting Functional Currency | (Dollars) |
|--------------------------------------|-----------|
| Other Income | 328 |
| Foreign currency gain (loss) | 18 |
| Asymmetric FXGL Adj. (paragraph (c)) | (18) |
| Asymmetric FXGL Adj. (paragraph (d)) | 18 |
| Total profit | 346 |
| Country A Tax | 49 |
| ETR | 14% |

Article 3.2.3¹

Example 3.2.3 - 1

Arm's Length Requirement for Cross-border Transactions

1. A Co, which is located in Jurisdiction A, and B Co, which is located in Jurisdiction B, are Constituent Entities of the same MNE Group. The nominal tax rate in Jurisdiction A is 25% and Jurisdiction B does not impose an income tax on Entities located therein. B Co provides services to A Co in Year 1. The financial accounts of A Co reflect an expense of 100 and the financial accounts of B Co reflect income of 100 in respect of the transaction. For tax purposes, however, A Co deducts 150 in respect of the services.

2. Article 3.2.3 requires transactions between Group Entities to be at the same price and consistent with the Arm's Length Principle. Where necessary to prevent double taxation or double non-taxation under the GloBE Rules, Article 3.2.3 requires an adjustment to the Financial Accounting Net Income or Loss when a Constituent Entity claims an amount of income or expense in a tax return attributable to a controlled transaction that differs from the amount reflected in the financial accounts.

3. In this scenario, A Co reported 150 of expense in its Jurisdiction A tax return for Year 1 and 100 of expense in its financial accounts for Year 1. B Co reported 100 of income in its financial accounts in Year 1. As a result, 50 of the MNE Group's income is not subject to tax in Jurisdiction A and is not exposed to Top-up Tax in Jurisdiction B. To avoid double non-taxation under the GloBE Rules, Article 3.2.3 requires A Co to include the 50 of additional expense in the computation of its GloBE Income or Loss for Year 1 and B Co to include 50 of additional income in the computation of its GloBE Income or Loss for Year 1.

¹ Examples 3.2.3 – 1, 3.2.3 – 2 and 3.2.3 – 3 do not implicate Article 4.6.1 because the adjustments are made contemporaneously with the filing of the relevant tax returns.

Example 3.2.3 - 2

Arm's Length Requirement for Cross-border Transactions

1. The facts are the same as in Example 3.2.3 – 1, except that A Co reported 80 of expense from the transaction with B Co in its Jurisdiction A tax return in accordance with a unilateral Advance Pricing Agreement concluded with Jurisdiction A.
2. In this scenario, A Co reported 80 of expense in its Jurisdiction A tax return for Year 1 and 100 of expense in its financial accounts for Year 1. B Co reported 100 of income in its financial accounts in Year 1. As a result, A Co is subject to tax in Jurisdiction A on 20 of income that is also exposed to Top-up Tax in Jurisdiction B. To avoid double taxation under the GloBE Rules, Article 3.2.3 requires A Co to reduce the expense by 20 in the computation of its GloBE Income or Loss and B Co to include 20 less income in the computation of its GloBE Income or Loss.

Example 3.2.3 - 3

Arm's Length Requirement for Cross-border Transactions

1. The facts are the same as in Example 3.2.3 – 1, except that Jurisdiction B has a corporate income tax that has a nominal rate of 7.5% and B Co reported 50 of income from the transaction with A Co in Jurisdiction B in accordance with a unilateral Advance Pricing Agreement concluded with Jurisdiction B.
2. In this scenario, B Co reported 50 of income in its Jurisdiction B tax return for Year 1 and 100 of income in its financial accounts for Year 1. A Co reported 100 of expense in its Jurisdiction A tax return and its financial accounts in Year 1. The 50 of income that is both deducted in A Co's Jurisdiction A taxable income and excluded from B Co's Jurisdiction B taxable income is exposed to Top-up Tax in Jurisdiction B under the GloBE Rules because it is included in B Co's GloBE Income or Loss. An adjustment to conform to B Co's local tax treatment would cause double non-taxation under the GloBE Rules because the income would not be subject to tax in Jurisdiction A or exposed to Top-up Tax in Jurisdiction B. Accordingly, Article 3.2.3 neither requires nor permits an adjustment to the GloBE Income or Loss of A Co nor B Co.

Article 3.2.6

Example 3.2.6 - 1

Election to Spread Capital Gains Over Five Years

1. A Co is a Constituent Entity of an MNE Group. A Co is incorporated and tax resident in Country A and holds Local Tangible Assets. In Year 3, A Co disposed of a Local Tangible Asset and incurred a Net Asset Loss of EUR 25. In Year 5, A Co disposed of its remaining Local Tangible Assets for EUR 300. The carrying value of the Local Tangible Assets disposed of in Year 5 was EUR 100. As a result, a Net Asset Gain of EUR 200 was realised in Year 5. A Co made an Annual Election under Article 3.2.6 with respect to the Net Asset Gain in Year 5.
2. As discussed in the Commentary on Article 3.2.6, with the disposal of its Local Tangible Assets in Year 5, A Co realised an Aggregate Asset Gain of EUR 200. Because A Co also had incurred a Net Asset Loss of EUR 25 in Year 3, A Co first must allocate EUR 25 of the Aggregate Asset Gain to Year 3 under Article 3.2.6 (b). This is because Article 3.2.6(b) provides that Aggregate Asset Gain in the Election Year must first be carried-back to the earliest Loss Year and set-off against any Net Asset Loss.

3. Then, pursuant to Article 3.2.6(d), A Co must allocate the remaining EUR 175 evenly to each Fiscal Year in the Look-back Period, which consists of the four prior Fiscal Years and the Election Year. This results in a carry-back of EUR 35 to each Fiscal Year in the Look-back Period.

4. Article 3.2.6 is an ETR Adjustment Article. Pursuant to Article 5.4.1, A Co's GloBE Income or Loss, ETR and Top-up Tax must be recalculated for each of the prior Fiscal Years in the Look-back Period by including all of the Aggregate Asset Gain allocated to each year under Article 3.2.6(d).

5. The allocation of the Aggregate Asset Gain over the five years of the Look-back Period can be summarised as follows:

| Aggregate Asset Gain | Year 1 | Year 2 | Year 3 | Year 4 | Year 5 / Election year |
|----------------------|--------|--------|--------|--------|------------------------|
| EUR 200 | EUR 35 | EUR 35 | EUR 60 | EUR 35 | EUR 35 |

Article 3.2.7

Example 3.2.7 - 1

Special Rule for Intra-Group Financing Arrangements

1. A Co is a Constituent Entity located in Country A where a 10% CIT rate applies. B Co is a Constituent Entity of the same MNE Group located in Country B where a 30% CIT rate applies. Prior to the transaction described below, the ETR of Country A for the MNE Group is 10% and for Country B is 30%.

2. A Co issues an interest bearing instrument to B Co in exchange for cash (i.e., A Co borrows from B Co), that is treated as debt for financial account purposes, but as equity for tax purposes in both Country A and Country B. As a result, payments on the instrument reduce the GloBE Income or Loss of A Co, while not reducing the Country A domestic tax liability of A Co. This is because the interest payments are included in income or expense for GloBE purposes, but dividends are not included in income or expense for tax purposes in Country A and Country B. Similarly, the payments on the instrument increase the GloBE Income or Loss of B Co, while not increasing the Country B domestic tax liability of B Co. As a result of the issuance of this instrument, the ETR for GloBE purposes of Country A will be increased and the ETR of Country B will be decreased.

3. This arrangement requires analysis under Article 3.2.7 to determine if it is an Intragroup Financing Arrangement. If the arrangement is an Intragroup Financing Arrangement, the operative provisions of Article 3.2.7 will apply.

4. Under Article 10.1, an Intragroup Financing Arrangement is an arrangement entered into between two or more members of the MNE Group whereby a High-Tax Counterparty directly or indirectly provides credit or otherwise makes an investment in a Low-Tax Entity.

5. Under Article 10.1, a High-Tax Counterparty is a Constituent Entity that is located in a jurisdiction that is not a Low-Tax Jurisdiction or that is located in a jurisdiction that would not be a Low-Tax Jurisdiction if its ETR were determined without regard to any income or expenses accrued by that Entity in respect of an Intragroup Financing Arrangement. A Low-Tax Jurisdiction is a jurisdiction where the MNE Group has Net GloBE Income and is subject to an ETR in that period lower than the Minimum Rate.

6. B Co is a High-Tax Counterparty because, notwithstanding this transaction, its ETR of 30% exceeds the Minimum Rate and therefore is not located in a Low-Tax Jurisdiction.

7. Because B Co is a High-Tax Counterparty, it must be determined if A Co is a Low-Tax Entity. A Low-Tax Entity means a Constituent Entity located in a Low-Tax Jurisdiction or that would be a Low-Tax Jurisdiction notwithstanding the transaction analysed. Since A Co has an ETR of 10% which is lower than the Minimum Rate notwithstanding this transaction, A Co is a Low-Tax Entity.

8. The final step of the Article 3.2.7 analysis is to determine whether, over the expected duration of the arrangement, it can be reasonably anticipated that:

- a. the arrangement will increase the amount of expenses taken into account in calculating the GloBE Income or Loss of the Low-Tax Entity (A Co);
- b. without resulting in a commensurate increase in the taxable income of the High-Tax Counterparty (B Co).

9. Because the instrument issued between B Co and A Co is treated as interest bearing debt for financial accounting purposes, it will increase the amount of expenses taken into account in calculating the GloBE Income or Loss of A Co, satisfying the first prong of the test described above.

10. The second prong of the Article 3.2.7 test is also satisfied because the instrument issued between B Co and A Co is treated as equity for tax purposes in Country B and accordingly will not increase the taxable income of B Co in Country B.

11. Since all requirements to apply Article 3.2.7 are met, the interest expense with respect to the instrument issued between B Co and A Co shall be excluded from the computation of GloBE Income or Loss for A Co.

Example 3.2.7 - 2

Special Rule for Intra-Group Financing Arrangements and use of tax attributes that would not otherwise be used to increase the ETR of a Low-Tax Entity

1. The facts are the same as in Example 1, except that the instrument issued between B Co and A Co is treated as debt for tax purposes in Country A and Country B. At the time the instrument is issued, A Co is highly-levered and cannot deduct any additional interest expense for Country A tax purposes. B Co is also highly-levered and has carried forward previously denied interest expense deductions for Country B tax purposes sufficient to shelter the interest income with respect to the instrument issued between B Co and A Co.

2. The interest expense incurred by A Co will satisfy the first prong of the Article 3.2.7 test because the interest expense increases the amount of expenses taken into account in calculating the GloBE Income or Loss of A Co.

3. The second prong of Article 3.2.7 is also satisfied because there is no commensurate increase in the taxable income of B Co. This is because B Co does not incur a commensurate increase in its Country B taxable income with respect to the interest income received from A Co given its excess interest expense carry-forward.

4. As in the previous example, since all requirements to apply Article 3.2.7 are met, the interest expense with respect to the instrument issued between B Co and A Co shall be excluded from the computation of GloBE Income or Loss for A Co

Article 3.3.1

Example 3.3.1 - 1

Exclusion of International Shipping Income and Qualified Ancillary International Shipping Income from GloBE Income or Loss

1. This example illustrates how the exclusion of International Shipping Income and Qualified Ancillary International Shipping Income provided under Article 3.3 operates. Assume a Constituent Entity has Financial Accounting Net Income of EUR 200. This Constituent Entity has an income of EUR 60 that was derived from performing an activity that is not covered by Article 3.3. In addition, this Constituent Entity has International Shipping Income of EUR 100 and Qualified Ancillary International Shipping Income of EUR 40. No adjustments other than the exclusion of International Shipping Income and Qualified Ancillary International Shipping Income are required to compute the GloBE Income of the Constituent Entity. The resulting GloBE Income of the Constituent Entity is EUR 60 (= 200 – (100 + 40)).

2. The adjustment required under Article 3.3.1 is illustrated in the following table.

| Computation of the GloBE Income of the Constituent Entity | Net Income |
|---|------------|
| [A] Financial Accounting Net Income or Loss | 200 |
| [B] Income (other than shipping) | 60 |
| [C] International Shipping Income | 100 |
| [D] Qualified Ancillary International Shipping Income | 40 |
| [E] Adjustment under Article 3.3.1 = [C+D] | 140 |
| GloBE Income = [A] – [E] | 60 |

Example 3.3.1 - 2

Exclusion of International Shipping Income and Qualified Ancillary International Shipping Income when Qualified Ancillary International Shipping Income exceeds the limitation provided under Article 3.3.4

1. This example illustrates how the exclusion of International Shipping Income and Qualified Ancillary International Shipping Income provided under Article 3.3 operates when the amount of Qualified Ancillary International Shipping Income exceeds the limitation provided under Article 3.3.4. The facts are the same as in Example 3.3.1 – 1, except that the amount of income that was derived from performing an activity that is not covered by Article 3.3 is EUR 40 and the amount of Qualified Ancillary International Shipping Income is EUR 60.

2. Article 3.3.4 provides that the aggregated Qualified Ancillary International Shipping Income of all Constituent Entities located in a jurisdiction shall not exceed 50% of those Constituent Entities' International Shipping Income. Therefore, the total amount of Qualified Ancillary International Shipping Income is limited to EUR 50 in this example. The resulting GloBE Income of the Constituent Entity is EUR 50 (= 200 – (100 + 50)).

3. The adjustment required under Article 3.3.1 is illustrated in the following table.

| Computation of the GloBE Income of the Constituent Entity | Net Income |
|--|-------------------|
| [A] Financial Accounting Net Income or Loss | 200 |
| [B] Income (other than shipping) | 40 |
| [C] International Shipping Income | 100 |
| [D] Qualified Ancillary International Shipping Income | 60 |
| [D] Negative adjustment under Article 3.3.4 that limits [D] to 50% x [C] | (10) |
| [E] Adjustment under Article 3.3.1 = [C+D+D] | 150 |
| GloBE Income = [A] – [E] | 50 |

Example 3.3.1 - 3

Exclusion of International Shipping Loss and Qualified Ancillary International Shipping Loss

1. This example illustrates how the exclusion of International Shipping Income and Qualified Ancillary International Shipping Income provided under Article 3.3 operates when they are negative (i.e. they generate a Loss).
2. The facts are the same as in Example 3.3.1 – 1, except that the Constituent Entity has an income of EUR 360 that was derived from performing an activity that is not covered by Article 3.3 and that, in addition, this Constituent Entity has International Shipping loss of EUR 100 and Qualified Ancillary International Shipping loss of EUR 60. Although the Financial Accounting Net Income of the Constituent Entity is EUR 200, the GloBE Income of the Constituent Entity is EUR 360 (= 200 - (-100 - 60) = 200 + 160).
3. The adjustment required under Article 3.3.1 is illustrated in the following table.

| Computation of the GloBE Income of the Constituent Entity | Net Income |
|--|-------------------|
| [A] Financial Accounting Net Income or Loss | 200 |
| [B] Income (other than shipping) | 360 |
| [C] International Shipping Income | (100) |
| [D] Qualified Ancillary International Shipping Income | (60) |
| [E] Adjustment under Article 3.3.1 = [C+D] | (160) |
| GloBE Income = [A] – [E] | 360 |

Chapter 4 – Examples

Article 4.1.3

Example 4.1.3 – 1

Net Basis Taxes

1. A Co is member of an MNE Group that is subject to the GloBE Rules and it is located in Country A, which imposes a 20% corporate income tax. In a Fiscal Year, A Co receives a dividend of 100 that is excluded from the computation of GloBE Income or Loss under Article 3.2.1(b). The dividend, however, is included in the computation of the taxable income in Country A.
2. In the same Fiscal year, A Co earns an additional 100 of Country A taxable income that is also GloBE Income. Accordingly, for Country A tax purposes, A Co records taxable income of 200 (Dividend of 100 + Operating Income of 100) and Country A tax of 40 (20% x 200).

| | Year 1 |
|--------------------------------|--------|
| A Co Domestic Taxable Income: | |
| Dividend | 100 |
| Operating Income | 100 |
| Total Country A Taxable Income | 200 |
| Country A Tax (20%) | 40 |
| A Co GloBE Income: | |
| Dividend | 0 |
| Operating Income | 100 |
| Total A Co's GloBE Income | 100 |

3. Article 4.1.3(a) requires that the amount of current tax expense with respect to income excluded from the computation of GloBE Income or Loss must reduce Covered Taxes for a Constituent Entity. Accordingly, the Country A tax relating to the dividend that has been excluded for GloBE purposes must be removed from the Adjusted Covered Taxes of A Co for GloBE purposes.
4. To determine the amount of Article 4.1.3(a) reduction attributable to the excluded income, the amount of excluded income shall be divided by the taxable income for the jurisdiction and then multiplied by the current tax expense.
5. In this case, there is excluded income of 100 (the dividend received) and taxable income of 200 (Dividend of 100 + Operating Income of 100). Dividing 100 by 200 results in a 50% reduction of A Co's taxable income in Country A. This percentage is then multiplied by the 40 of A Co's Country A tax, to remove 20 of tax from the Covered Tax computation for A Co.
6. As a result, for the Fiscal Year, A Co has GloBE Income of 100 (since the dividend is excluded) and an ETR of 20% (20 Covered Tax / GloBE Income of 100).

Article 4.1.5

Example 4.1.5 – 1

Imposition of top-up tax in loss year

1. A Co is a Constituent Entity of an MNE Group that is subject to the GloBE Rules. A Co is the only Constituent Entity located in Country A. The only tax imposed on A Co under Country A law is corporation tax which is imposed at the rate of 15%. Country A provides for the carry-forward of tax losses, which allows a taxpayer to carry forward such losses into a subsequent period to be used to reduce taxable income in future years.

2. In Year 1, A Co has income of 120 and expenditure of (220) under the GloBE Rules resulting in a total GloBE Loss for the period of (100). However, under the tax laws of Country A, A Co is only treated as having taxable income of 100. This is due to the fact that 20 of A Co's income results from a capital gain that is excluded from tax under Country A law. The table below illustrates the tax position of A Co for local tax and GloBE purposes. The table on the left shows A Co's loss as determined for local tax purposes while the table on the right shows the same calculation as determined under the GloBE Rules.

| Local Tax | | GloBE | |
|---------------------|-------|--|-------|
| Income | 100 | Income | 100 |
| | | Capital gain excluded under local law | 20 |
| Expenditure | (220) | Expenditure | (220) |
| Total Profit (Loss) | (120) | Total Profit (Loss) | (100) |
| Tax (Tax benefit) | (18) | Expected Adjusted Covered Taxes Amount | (15) |

3. The local tax loss of A Co is greater than the loss that has been recorded for GloBE purposes. The additional tax loss of 20 under Country A law results from the fact that Country A law does not include the 20 of capital gain (i.e. the additional loss is a permanent difference in respect of a non-economic loss). A Co's tax loss gives rise to a deferred tax asset for financial accounting purposes equal to the tax loss multiplied by the corporate tax rate ($120 \times 15\% = 18$). The generation of this deferred tax asset is incorporated into A Co's Total Deferred Tax Adjustment Amount under Article 4.4.1 and treated as a reduction to A Co's Adjusted Covered Taxes under Article 4.1.1. When the loss carry-forward is used in a subsequent year in Country A, the deferred tax asset is treated as an addition to A Co's Adjusted Covered Taxes under the mechanics of the same provisions.

4. In a Fiscal Year in which there is no Net GloBE Income for a jurisdiction, if the Adjusted Covered Taxes for a jurisdiction are less than zero and less than the Expected Adjusted Covered Taxes Amount, the Constituent Entities in that jurisdiction shall be treated as having Additional Current Top-up Tax for the jurisdiction under Article 5.4 arising in the current Fiscal Year equal to the difference between these amounts. The Expected Adjusted Covered Taxes Amount is equal to the GloBE Income or Loss for a jurisdiction multiplied by the Minimum Rate.

5. In this case A Co has a GloBE Loss and it is the only Constituent Entity located in Country A. This means there is no Net GloBE Income in Country A. A Co's Expected Adjusted Covered Taxes Amount for the year is A Co's GloBE Loss of (100) multiplied by the Minimum Rate of 15% [$(100) \times 15\% = (15)$].

6. A Co's Adjusted Covered Taxes (18) are less than A Co's Expected Adjusted Covered Taxes Amount (15). A Co therefore has additional Top-up Tax of EUR 3 in Year 1 under Article 4.1.5. Imposing an immediate tax charge on A Co in Year 1 means that the additional tax asset generated for local tax purposes can be recognised in the Adjusted Covered Taxes Amount while preserving the adherence between the deferred tax expense of A Co under the financial accounting rules and the GloBE Rules (i.e.

the EUR 18 deferred tax asset determined for financial accounting purposes is also used for GloBE purposes). Article 4.1.5 thereby ensures that the permanent difference giving rise to the inflated tax loss does not result in an overstated ETR for Country A when the deferred tax attribute is later used.

7. Assume that, in Year 2, A Co has 220 of income and (100) of expenditure resulting in 120 of profit that is included in both GloBE Income and taxable income. As A Co uses EUR 120 loss carry-forward under local tax rules from Year 1, A Co has 120 of GloBE Income, zero taxable income and zero current tax expense in Year 2. The full deferred tax asset of EUR 18, however, is included in the Adjusted Covered Taxes in Year 2 under Article 4.4 and no Top-up Tax is expected to arise.

8. The table below illustrates the tax position of A Co for local tax and GloBE purposes in Year 2. The table on the left shows A Co's position for local tax purposes while the table on the right shows the ETR calculation under the GloBE Rules.

| Local Tax | | GloBE | |
|---------------------|-------|--------------------------|-------|
| Income | 220 | Income | 220 |
| Expenditure | (100) | Expenditure | (100) |
| Loss offset | (120) | | |
| Total Profit (Loss) | 0 | Total Profit | 120 |
| | | Adjusted Covered Taxes - | 18 |
| | | GloBE ETR | 15% |

Example 4.1.5 – 2

Adjusted Covered Taxes

1. The facts are the same as in Example 4.1.5 - 1, except that:
 - a. A Co 1 and A Co 2 are Constituent Entities of an MNE Group that is subject to the GloBE Rules and are both located in Country A;
 - b. In Year 1, A Co 1 has the same tax implications as A Co (GloBE Loss (100); deferred tax asset of 18); and
 - c. In Year 1, A Co 2 has a total GloBE Income of 50.
2. Under this scenario, if the Adjusted Covered Taxes in Country A are less than zero and less than the Expected Adjusted Covered Taxes Amount, A Co 1 and A Co 2 are treated as having Additional Current Top-up Tax arising in Year 1 and equal to the difference between these two amounts under Article 4.1.5.
3. A Co 1 and A Co 2's Expected Adjusted Covered Taxes Amount for Year 1 is equal to the GloBE Income or Loss for the jurisdiction multiplied by the Minimum Rate. For this reason, A Co 1's deferred tax asset of (18) has to be added to A Co 2's Covered Taxes of 7.5 (15% * 50), which results in Adjusted Covered Taxes for Country A of (10.5). A Co 1 and A Co 2's Expected Adjusted Covered Taxes Amount for Year 1, is A Co 1 and A Co 2's GloBE Loss of (50) multiplied by the Minimum Rate of 15% [(50) x 15% = (7.5)].
4. As the Adjusted Covered Taxes (10.5) are less than zero and less than the Expected Adjusted Covered Taxes Amount (7.5), an Additional Current Top-up Tax of 3 arises under Article 4.1.5. The Additional Current Top-up Tax of 3 is then allocated to A Co 1 under Article 5.4.3 as A Co 1 recorded an Adjusted Covered Taxes amount that is less than zero and less than the GloBE Income or Loss multiplied by the Minimum Rate.
5. A table illustrating the numerical results of this example is set out below.

| | A Co 1 | A Co 2 | Jurisdictional (Country A) |
|--|--------|--------|-------------------------------|
| GloBE Income or (Loss) | (100) | 50 | (50) |
| Deferred Tax Asset | (18) | - | |
| Covered Taxes | - | 7.5 | |
| Expected Adjusted Covered Taxes Amount | | | (7.5) |
| Adjusted Covered Taxes Amount | (18) | 7.5 | (10.5) |
| Additional Current Top-up Tax | | | 3 |

Example 4.1.5 – 3

Adjusted Covered Taxes

6. The facts are the same as in Example 4.1.5 - 2, except that Country A has an income tax rate of 25%.

7. In this scenario, A Co 2 has Adjusted Covered Taxes of 12.5 ($50 * 25\%$). The Expected Adjusted Covered Taxes Amount of Country A in Year 1 remains (7.5) because the GloBE Loss is always multiplied by the Minimum Rate ($15\% * (50)$). As the deferred tax asset of A Co 1 was recast at the Minimum Rate in accordance with Article 4.4.1, it remains (18) and is added to the Adjusted Covered Taxes of A Co 2 of 12.5, which results in Adjusted Covered Taxes for Country A of (5.5).

8. Because the Adjusted Covered Taxes amount for Country A of (5.5) is not less than the Expected Adjusted Covered Taxes Amount of (7.5), no adjustment is required in this case under Article 4.1.5. The taxes accrued by A Co 2 in Year 1 are sufficient to shelter the permanent difference in A Co 1 from Top-up Tax. A table illustrating the numerical results of this example is set out below:

| | A Co 1 | A Co 2 | Jurisdictional (Country A) |
|--|--------|--------|-------------------------------|
| GloBE Income or (Loss) | (100) | 50 | (50) |
| Deferred Tax Asset | (18) | - | |
| Covered Taxes | - | 12.5 | |
| Expected Adjusted Covered Taxes Amount | | | (7.5) |
| Adjusted Covered Taxes Amount | (18) | 12.5 | (5.5) |
| Additional Current Top-up Tax | | | 0 |

Example 4.1.5 - 4

Excluded Dividends under Article 4.1.5

1. A Co is located in Country A, which imposes a domestic corporate income tax rate of 25%. The tax base in Country A is the same as the GloBE base. In a Fiscal Year, A Co receives dividend income of 100, which is excluded from GloBE Income or Loss under Article 3.2(b). A Co also incurs expenses of 150, which directly relate to the dividend income, during the Fiscal Year. Because Article 3.2(b) only excludes dividend income, A Co has a GloBE Loss of (150) for the Fiscal Year, since the dividend is excluded. No

Top-up Tax under Article 4.1.5 will arise, because the Expected Adjusted Covered Taxes Amount for A Co is (22.5) and the actual deferred tax asset established for GloBE purposes is also (22.5) (i.e., the domestic tax loss of (150) multiplied by the 15% Minimum Rate).

Article 4.3.3

Example 4.3.3 - 1

Adjusted Covered Taxes (CFC Tax push-down limitation)

1. A Co is a Constituent Entity of a MNE Group in Country A. Country A imposes a 25% CIT rate and has a Controlled Foreign Company (CFC) Tax Regime which imposes Taxes on shareholders in respect of Passive Income derived by foreign (CFC) subsidiaries.
2. A Co wholly owns B Co, which is located in Country B. Country B imposes a 5% CIT rate. B Co is the only Constituent Entity located in Country B.
3. In Year 1, B Co has GloBE Income of EUR 100, of which EUR 50 is Passive Income that is subject to the CFC Tax Regime of Country A.
4. Country A imposes its CFC charge on the EUR 50 of Passive Income earned by B Co. This CFC charge is computed by applying the Country A CIT rate of 25% to the Passive Income earned by B Co, less any applicable foreign tax credit (FTC). Accordingly, the Country A CFC charge is 10 ((25% x 50) – (5% x 50)). A Co has no other operating income in Year 1. The table below illustrates the tax calculation for both A Co and B Co.

| A Co (Country A) | |
|---|-----------|
| <i>Country A Income</i> | |
| Operating Income | 0 |
| CFC Inclusion (B Co) | 50 |
| Total Taxable Income | 50 |
| <i>Country A Tax</i> | |
| Tax on Operating Income (25%) | 0 |
| Tax on CFC Inclusion (25%) | 12.5 |
| Foreign Tax Credit (CFC Inclusion) | -2.5 |
| Total Country A Tax* | 10 |
| <i>*Entirely attributable to CFC inclusion since there is no other income</i> | |

| B Co (Country B) | |
|------------------------------|------------|
| <i>Country B Income</i> | |
| Operating Income | 50 |
| Passive Income | 50 |
| Total Taxable Income | 100 |
| <i>Country B Tax</i> | |
| Tax on Operating Income (5%) | 2.5 |
| Tax on Passive Income (5%) | 2.5 |
| Total Country B Tax | 5 |

5. The amount of any CFC Taxes included in the financial accounts of a direct or indirect Constituent Entity-owner on its share of the Controlled Foreign Company's income is allocated to such CFC under Article 4.3.2(c). The allocation of CFC Taxes, however, is subject to the limitations of Article 4.3.3.
6. Under Article 4.3.3, the allocation of CFC Taxes is limited to the lesser of:
 - (a) the actual amount of Covered Taxes in respect of such Passive Income; or
 - (b) the Top-up Tax Percentage that applies in the subsidiary jurisdiction, multiplied by the amount of the subsidiary's Passive Income that is includible under the CFC Tax Regime.

For the purposes of this formula, the Top-up Tax Percentage is determined without regard to the Covered Taxes to be allocated to the subsidiary under the CFC Tax Regime.

7. The maximum amount of CFC Taxes that can be allocated from Country A to Country B (to increase its ETR) under Article 4.3.3 is therefore computed as follows:

- Step 1: the Top-up Tax Percentage for Country B is determined without regard to any Covered Taxes of the Constituent Entity-owner on such Passive Income. This amount is 10% (15% - 5%).
- Step 2: the Top-up Tax Percentage calculated under Step 1 is multiplied by the amount of the Constituent Entity's Passive Income includible under the CFC Tax Regime of Country A. This amount is EUR 5 (10% x EUR 50).
- Step 3: the lesser of the Step 2 amount or the actual CFC Taxes with respect to the Passive Income is allocated to B Co.

8. In this case the Step 2 amount is 5, while the actual CFC Tax amount is 10. Therefore, Covered Tax of 5 may be allocated under Article 4.3.3 from Country A to Country B. Absent the limitation in Article 4.3.3, Article 4.3.2 (c) would have allocated the full CFC Tax of EUR 10 to Country B. Article 4.3.3 ensures that the CFC Tax allocated from Country A to Country B is sufficient to reach the Minimum Rate with respect to the income brought into charge under the CFC Tax Regime. The remaining Covered Tax of EUR 5 in Country A stays with A Co and is included in its Adjusted Covered Taxes for purposes of determining the ETR in Country A. The table below illustrates the GloBE Calculations after Application of Article 4.3.3:

| A Co (Country A) | | B Co (Country B) | |
|---|----------|---|-----------|
| GloBE Income | 0 | GloBE Income | 100 |
| | | | 50 |
| Covered Taxes | | Covered Taxes | |
| Country A Tax | 10 | Country B Tax | 5 |
| CFC Tax Allocated to Country B | -5 | CFC Tax Allocated from Country A | 5 |
| <u>Total Country A Adjusted Covered Taxes</u> | <u>5</u> | <u>Total Country B Adjusted Covered Taxes</u> | <u>10</u> |
| ETR | - | ETR | 10% |
| Top-up Tax | - | Top-up Tax | 5 |

Article 4.4.1

Example 4.4.1 - 1

Total Deferred Tax Adjustment Amount – generation of tax credits

1. A Co is a Constituent Entity of an MNE Group that is subject to the GloBE Rules. A Co is the only Constituent Entity located in Country A. The only tax imposed on A Co under Country A law is corporation tax which is imposed at the rate of 25%. The tax base of Country A is the same as the GloBE tax base. Country A has a minimum tax regime that provides at least 17% corporate income tax must be paid in a taxable year.

2. In Year 1, A Co earns GloBE Income of 100 in Country A. The initial tax liability for A Co is therefore 25 but Country A provides an incentive tax credit to A Co of 15. Because of the Country A minimum tax regime, only 8 of the incentive tax credit may be used in Year 1 given the 17% minimum rate requirement. The remaining 7 of incentive tax credit is available for carry-forward to a future tax year. A Co therefore pays 17 of Country A tax in Year 1 and carries-forward an excess credit of 7.

3. In Year 2, A Co earns GloBE Income of 100 and has an initial tax liability in Country A of 25. A Co applies its remaining 7 tax credit carry-forward from Year 1 and pays 18 of Country A tax in Year 2.

4. Because Article 4.4.1(e) excludes deferred tax expense with respect to the generation and use of tax credits, the carry-forward of 7 generated in Year 1 does not give rise to a deferred tax asset for GloBE purposes, and therefore does not reduce the Adjusted Covered Taxes for Country A in Year 1. Applying the same rule, the use of the credit carry-forward of 7 in Year 2 does not increase Adjusted Covered Taxes for Country A in Year 2. As a result, the Country A ETR is 17% in Year 1 (17/100) and 18% in Year 2 (18/100). A table illustrating the numerical results of this example is set out below.

| | Year 1 | Year 2 |
|----------------------------------|--------|--------|
| GloBE Income/ (Loss) | 100 | 100 |
| Country A Tax (25%) | (25) | (25) |
| Tax Credit Generated | 15 | 0 |
| Carry-forward Tax Credit Applied | 0 | 7 |
| Minimum Tax Adjustment | (7) | 0 |
| Final Country A Tax | (17) | (18) |
| Country A ETR | 17% | 18% |
| Top-up Tax | 0 | 0 |
| Excess Tax Credit Carry-forward | 7 | 0 |

5. Absent the rule in Article 4.4.1(e), the Country A results would have been distorted by the generation of excess tax credits in Year 1, as the credit carry-forward would give rise to a deferred tax asset that would otherwise reduce Adjusted Covered Taxes below the Minimum Rate.

Chapter 5 - Examples

Article 5.3.7 (a)

Example 5.3.7 - 1

Substance-based Income Exclusion

1. This example illustrates the application of the Substance-based Income Exclusion in the situation in which a Flow-through Entity has Eligible Payroll Costs and Eligible Tangible Assets.
2. A Co is located in Country A and is the UPE of the AB Group. A Co owns 50% of the Ownership Interests of B Co 1 and 100% of the Ownership Interests of B Co 2. The remaining Ownership Interests of B Co 1 are held by B Co 2 (45%) and non-Group Entities (5%).
3. Furthermore, B Co 1 is a Flow-through Entity and conducts business operations in Country B. A Co has a PE in Country B as a result of the business being carried out by B Co 1 in Country B. A Co, B Co 1, B Co 2 and the PE are Constituent Entities of the AB Group.
4. B Co 1 earns EUR 1,000 of GloBE Income in Year 1, incurs EUR 200 of Eligible Payroll Costs in respect of employees that work in Country B and has EUR 400 of Eligible Tangible Assets located in Country B.

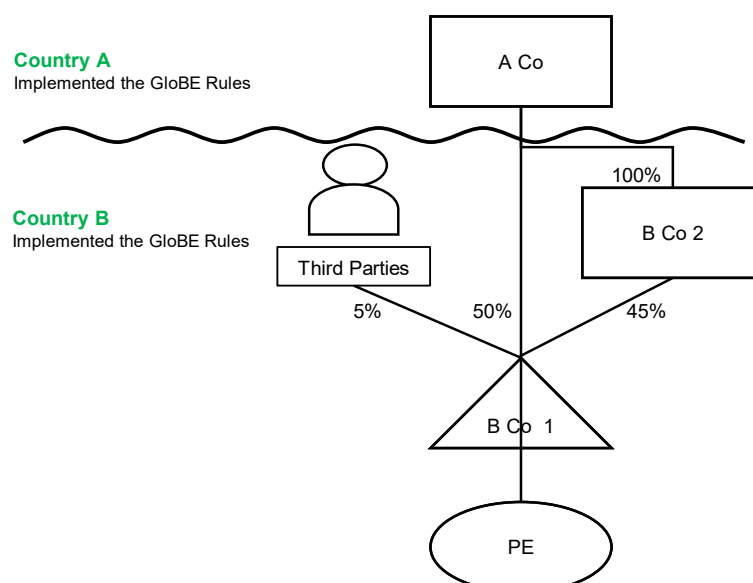

5. B Co 1's GloBE Income is reduced and allocated as follows. First, B Co 1's GloBE Income is reduced by EUR 50, the amount allocable to persons that are not Group Entities, under Article 3.5.3. Next, EUR 500 of B Co 1's GloBE Income is allocated to the PE in accordance with Article 3.4 and reduced from

its GloBE Income under Article 3.5.1 (a). Finally, the remaining EUR 450 of B Co 1's GloBE Income is allocated to B Co 2 under Article 3.5.1 (b).

6. B Co 1's Eligible Payroll Costs and Eligible Tangible Assets are allocated as follows. 50% of B Co 1's Eligible Payroll Costs (EUR 100) and Eligible Tangible Assets (200) are allocated to the PE under Article 5.3.6. Under Article 5.3.7(a), 45% of B Co 1's Eligible Payroll Costs (EUR 90) and Eligible Tangible Assets (EUR 180) are then allocated to B Co 2 because B Co 2 is located in Country B. The remainder of B Co 1's Eligible Payroll Costs (EUR 10) and Eligible Tangible Assets (EUR 20) are not included in the computation of a Constituent Entity's Substance-based Income Exclusion under Article 5.3.7 (c).

Article 5.5.2

Example 5.5.2 - 1

De minimis exclusion – short Fiscal Years taken into account in the average

1. This example illustrates how the computation of the Average GloBE Revenue and Average GloBE Income is adjusted in the situation where there is a short Fiscal Year.

2. Assume the ABC Group uses the calendar year as its Fiscal Year and has only one Constituent Entity in Jurisdiction B, B Co. B Co was created on 1 July in Year 1 and it had GloBE Revenue of EUR 1 million and a GloBE Income of EUR 50,000 in Year 1. Assume that in Year 2, B Co has GloBE Revenue of EUR 1 million and a GloBE Income of EUR 100,000. In Year 3, B Co has GloBE Revenue of EUR 3 million and a GloBE Loss of EUR 200,000. B Co only generates GloBE Revenue, GloBE Income, and GloBE Loss in Jurisdiction B. This example illustrates how the computation is performed and assesses whether the Top-up Tax for B Co may be deemed to be zero for Fiscal Year 3.

3. The computation of the average amounts under Article 5.5.2 relies on the assumption that Fiscal Years have the same duration. If one Fiscal Year is shorter, the average shall be computed by adjusting the corresponding GloBE Revenue and GloBE Income (or Loss) calculations in proportion to the period covered by the short Fiscal Year over a 12 month period. Therefore, in Year 1, as B Co's GloBE Revenue and GloBE Income were only realized over 6 months (1 July - 31 December), the GloBE Revenue and the GloBE Income of Year 1 will be multiplied by 2 (= 12/6) for the purposes of determining the average annual GloBE Revenue and GloBE Income.

4. The computation of the average is made as follows:

5. The three-year Average GloBE Revenue for this jurisdiction is:

$$\frac{(2 \times 1 \text{ million}) + 1 \text{ million} + 3 \text{ million}}{3} = \text{EUR 2 million}$$

And the three-year Average GloBE Revenue or Loss for this jurisdiction is:

$$\frac{(2 \times 50,000) + 100,000 + (-200,000)}{3} = \text{EUR 0}$$

6. The Average GloBE Revenue of Jurisdiction B is less than EUR 10 million and the Average GloBE Income or Loss of Jurisdiction B is less than EUR 1 million. As a consequence, the Top-up Tax for B Co shall be deemed to be zero for Year 3 if the Filing Constituent Entity elects for it under the GloBE Rules.

Chapter 6 - Examples

Article 6.2.1 (e)

Example 6.2.1 - 1

Constituent Entities joining and leaving an MNE Group

1. ABC Group sells all the shares of its wholly-owned Constituent Entity, C Co, to DEF Group at a price of EUR 200 on 30 September in Year 2. C Co holds a single asset, which is an Eligible Tangible Asset that has a carrying value of EUR 100 as recorded for the purposes of preparing ABC Group's Consolidated Financial Statements at the end of Year 1 (which is also the carrying value at the beginning of the Year 2). The carrying value of the asset at the end of Year 2 is EUR 20 because C Co claimed EUR 80 of depreciation in respect of the asset during the period that it was owned by ABC Group in Year 2. The Fiscal Years end in December.

2. The computation of the carrying value of the asset for purposes of Article 5.3.4 has to be based on the average of the carrying value at the beginning and ending of the Reporting Fiscal Year as recorded for purposes of preparing the Consolidated Financial Statements of the UPE (see Article 5.3.5). Under Article 6.2.1(e), the carrying value must be adjusted proportionally to the length of the relevant Fiscal Year that C Co was a member of the ABC Group. The carrying value of the asset for ABC Group is therefore EUR 45 $[(\text{EUR } 100 + \text{EUR } 20) / 2] \times (9/12)$.

3. In the case of DEF Group, the carrying value of the Eligible Tangible Asset of the acquired C Co at the beginning of the Reporting Fiscal Year (Year 2) is zero. However, at the end of Year 2 the carrying value is EUR 200 because the UPE's Consolidated Financial Statements reflect the fair value of the asset based on the indirect acquisition cost of the asset adjusted for accumulated depreciation by the DEF Group. Taking into account the carrying value of the asset at the beginning and end of DEF Group's Reporting Fiscal Year (Year 2) and the length of Year 2 that C Co was a member of the DEF Group, the carrying value of the asset under Article 6.2.1(e), is equal to EUR 25 $[(\text{EUR } 0 + \text{EUR } 200) / 2] \times (3/12)$.

Chapter 7 – Examples

Article 7.1.1 (a)

Example 7.1.1(a) - 1

Ultimate Parent Entity that is a Flow-through Entity

1. A Co is a Flow-through Entity that is the UPE of an MNE Group. A Co is located in Country A and has a Fiscal Year that ends on 31 January. Person 1 is an individual tax resident in Country A while Person 2 is an individual tax resident in Country B. Person 1 and Person 2 each hold a 50% of the Ownership Interests in A Co. For the Fiscal Year ended 31 January Year 1, A Co reports EUR 140,000 of income both for domestic income tax and GloBE purposes.

2. Under the tax laws of Country A, EUR 70,000 of A Co's income is included in the taxable income of Person 1 for the calendar year ended 31 December Year 1. The computation of the taxable income of Person 1 also includes a loss of EUR 50,000 from another business conducted in Country A. The taxable income of Person 1 under the tax laws of Country A is EUR 20,000 (= 70,000 – 50,000) and Person 1 is subject to tax in Country A at a rate of 20% on such taxable income.

3. Under the tax laws of Country A, Person 2 is treated as having a PE in Country A and the taxable income of that PE includes EUR 70,000 of A Co's taxable income. Person 2 is subject to tax in Country A at a rate of 20% on the income of its PE for the calendar year ended 31 December Year 1.

4. A Flow-Through Entity that is the UPE reduces its GloBE Income pursuant to Article 7.1.1(a)(i) by the amount of GloBE Income attributable to an Ownership Interest if (1) the holder is subject to tax on that income for a taxable period that ends within 12 months of the end of the MNE Group's Fiscal Year and (2) the holder of the Ownership Interest is subject to tax on the full amount of such income at a nominal rate that equals or exceeds the Minimum Rate.

5. Person 1 is subject to tax on his/her share of A Co's GloBE Income for a taxable period that ends on 31 December Year 1, which is within 12 months of the end of A Co's Fiscal Year ended on 31 January Year 1, notwithstanding that payment of Person 1's tax liability is not due within 12 months of the end of A Co's Fiscal Year. Further, Person 1 is subject to tax on his/her share of A Co's GloBE Income at a nominal rate that equals or exceeds the Minimum Rate. Person 1 is subject to tax on the full amount of such income notwithstanding that he/she was allowed to offset his/her share of A Co's GloBE Income with a loss from another business in computing his/her Country A taxable income. Accordingly, A Co reduces its GloBE Income for the Fiscal Year ended 31 January Year 1 pursuant to Article 7.1.1(a)(i) by EUR 70,000 in respect of the Ownership Interests held by Person 1. A Co will reduce its Covered Taxes proportionately under Article 7.1.3.

6. Person 2 is subject to tax on his/her share of A Co's GloBE Income for a taxable period that ends within 12 months of the end of A Co's Fiscal Year. Person 2 is also subject to tax on the full amount of such income at a nominal rate that equals or exceeds the Minimum Rate. Accordingly, A Co reduces its GloBE Income for the Fiscal Year ended 31 January Year 1 pursuant to Article 7.1.1(a)(i) by EUR 70,000

in respect of the Ownership Interests held by Person 2. A table illustrating the results of this example is set out below.

| | Person 1 | Person 2 |
|--|----------|----------|
| <i>GloBE Income</i> | 70,000 | 70,000 |
| <i>Tax at Minimum Rate</i> | 15% | 15% |
| <i>Nominal Rate</i> | 20% | 20% |
| <i>GloBE Income reduction Article 7.1.1 (a)(i)</i> | Yes | Yes |

Example 7.1.1(a) - 2

UPE that is a Flow-through Entity

1. C Co is a Flow-through Entity and a Tax Transparent Entity that is the UPE of an MNE Group. C Co is located in Country C where a 5% CIT rate applies. C Co's taxable income and GloBE Income for the Fiscal Year ended on 31 December Year 1 is EUR 200,000. The Adjusted Covered Taxes of C Co on its income are EUR 10,000 (= 5% * EUR 200,000) and such taxes meet the definition of Covered Taxes (see Article 4.2).

2. Person 3 is an individual tax resident in Country C that holds a 50% Ownership Interest in C Co. Person 3's share of C Co's income for Year 1 is EUR 95,000 (= 50% * [EUR 200,000 – 10,000]). Person 3 is subject to a nominal 11% personal income tax rate on a calendar year basis. Person 3's share of C Co's income for the Fiscal Year ended on 31 December Year 1 is included in Person 3's Country C taxable income for the calendar year that ended 31 December Year 1. Person 3 is not entitled to reduce its Country C tax imposed on its share of C Co's income as a result of Country C taxes imposed on such income.

3. C Co cannot reduce its GloBE Income pursuant to subparagraph (i) of Article 7.1.1(a) because the personal income tax rate applicable to Person 3 is 11%, which is a nominal rate below the Minimum Rate. However, a Flow-Through Entity that is the UPE reduces its GloBE Income pursuant to subparagraph (ii) of Article 7.1.1(a) by the amount of GloBE Income attributable to an Ownership Interest if (1) the holder is subject to tax on that income for a taxable period that ends within 12 months of the end of the MNE Group's Fiscal Year and (2) it can reasonably be expected that the aggregate amount of Adjusted Covered Taxes of the UPE and Taxes of the holder of the Ownership Interest on such income equals or exceeds the amount that results from multiplying the full amount of such income by the Minimum Rate (see Article 7.1.1 (a)(ii)).

4. Person 3 is reasonably expected to pay EUR 10,450 of Taxes (= 11% * EUR 95,000 after-tax income of C Co) in Country C. The sum of the Taxes paid by Person 3 and C Co on the EUR 100,000 of GloBE Income attributable to Person 3 is EUR 15,450 (= EUR 10,450 paid by Person 3 + EUR 5,000 paid by C Co), which exceeds the amount (EUR 15,000) that results from multiplying the full amount of such income by the Minimum Rate (EUR 100,000 * 15%). C Co will therefore reduce its EUR 200,000 GloBE Income in Year 1 by the EUR 100,000 GloBE Income attributable to Person 3's Ownership Interest. C Co will reduce its Covered Taxes proportionally under Article 7.1.3. A table illustrating the numerical results of this example is set out below.

| | EUR |
|----------------------------|---------|
| <i>GloBE Income</i> | 100,000 |
| <i>Tax at Minimum Rate</i> | 15,000 |
| <i>Taxes (C Co)</i> | 5,000 |
| <i>Taxes (Person 3)</i> | 10,450 |

| | |
|--|--------|
| Aggregate Taxes | 15,450 |
| GloBE Income reduction Article 7.1.1 (a)(ii) | Yes |

5. C Co would not have been entitled to reduce its GloBE Income if Person 3 was granted a tax credit in Country C equal to the amount of Taxes paid by C Co. In that case, it would not be reasonable to expect the aggregate amount of Taxes (EUR 11,000) paid by Person 3 (EUR 6,000) and C Co (EUR 5,000) to equal or exceed the amount that results from multiplying the full amount of GloBE Income by the Minimum Rate. A table illustrating the numerical results of this paragraph is set out below.

| | EUR |
|--|-------------|
| GloBE Income | EUR 100,000 |
| Tax @ Minimum Rate | EUR 15,000 |
| Taxes (C Co) | EUR 5,000 |
| Taxes (Person 3) | EUR 6,000 |
| Aggregate Taxes | EUR 11,000 |
| GloBE Income reduction Article 7.1.1 (a)(ii) | No |

Article 7.1.4

Example 7.1.4 - 1

UPE that is a Flow-through Entity

1. A Co is the UPE of ABC Group. A Co is a Flow-through Entity and a Tax Transparent Entity created in Country A with two owners, each of whom holds 50% of its Ownership Interests. A Co conducts business operations in Countries A and B. The place of business through which A Co carries out business operations in Country B creates a PE in Country B. Overall, A Co generated GloBE Income of EUR 300 in Countries A and B during a Fiscal Year.

2. Under the rules of Articles 3.4 and 3.5, EUR 100 of A Co's income is allocated to a PE located in Country B (see Article 3.5.1 (a)). Country B imposes tax on the owners of A Co in respect of the EUR 100 income allocated to PE at a 15% nominal rate and each owner paid EUR 7.5 of tax to Country B (total EUR 15).

3. In Country B, the holders of A Co's Ownership Interests are subject to tax at a nominal rate that equals the Minimum Rate and it is reasonable to expect that the EUR 7.5 tax paid by each holder equals the amount of each holders' share of the PE's income multiplied by the Minimum Rate, or EUR 7.5 (= 50 income x 15% Minimum Rate). Accordingly, PE's GloBE Income is reduced by EUR 100 in Country B pursuant to Article 7.1.4.

4. A table illustrating the numerical results of this example is set out below.

| A Co | Country B |
|--------------------------------|-----------|
| Allocation income | EUR 100 |
| Tax rate | 15% |
| Tax paid | EUR 15 |
| Tax above/(below) Minimum Rate | EUR 0 |
| Tax reduction Article 7.1.4 | Yes |

Article 7.3

Example 7.3.4 - 1

Eligible Distribution Tax Regime

1. A Co is a Constituent Entity of an MNE Group and it is located in a jurisdiction with an Eligible Distribution Tax Regime. Distributions (and deemed distributions) are subject to tax at a 15% rate. An election pursuant to Article 7.3.1 is made for Year 1, Year 2, and Year 3 with respect to the jurisdiction. A Co makes no actual or deemed distributions in Year 1, Year 2, or Year 3.

2. In Year 1, A Co earns GloBE Income of EUR 100 and records Deemed Distribution Tax of EUR 15 pursuant to Article 7.3.2(a). Accordingly, the balance of the Deemed Distribution Tax Recapture Account at the end of Year 1 is EUR 15 (see Article 7.3.4).

3. In Year 2, A Co incurs a Net GloBE Loss of EUR 120. Under Article 7.3.3, the Net GloBE Loss is multiplied by the Minimum Rate (i.e., EUR 120 x 15% = EUR 18) and EUR 15 is applied to reduce the Deemed Distribution Tax Recapture Account to EUR 0 (Article 7.3.3(b)). The excess over the Deemed Distribution Tax Recapture Account, EUR 3 (= EUR 18 – EUR 15), is added to a Recapture Account Loss Carry-forward.

4. In Year 3, A Co earns GloBE Income of EUR 100 and Deemed Distribution Tax of EUR 15 is recorded to achieve the Minimum Rate (see Article 7.3.2(a)). The Deemed Distribution Tax Recapture Account is increased by EUR 15 and then reduced by EUR 3, the balance of the Recapture Account Loss Carry-forward from Year 2, leaving a balance of EUR 12 in the Deemed Distribution Tax Recapture Account established for Year 3.

| | Year 1 | Year 2 | Year 3 |
|---|---------|-----------|---------|
| GloBE Income (or Loss) | EUR 100 | (EUR 120) | EUR 100 |
| Tax at Minimum Rate | EUR 15 | (EUR 18) | EUR 15 |
| Deemed Distribution Tax Recapture Account | EUR 15 | EUR 0 | EUR 12 |
| Recapture Account Loss Carry-forward | EUR 0 | EUR 3 | EUR 0 |

Tax Challenges Arising from the Digitalisation of the Economy – Global Anti-Base Erosion Model Rules (Pillar Two) Examples

INCLUSIVE FRAMEWORK ON BEPS

A key part of the OECD/G20 BEPS Project is addressing the tax challenges arising from the digitalisation of the economy. In October 2021, over 135 jurisdictions joined a ground breaking plan to update key elements of the international tax system which is no longer fit for purpose in a globalised and digitalised economy. The Global Anti-Base Erosion Rules (GloBE), published in December 2021, are a key component of this plan and ensure large multinational enterprise pay a minimum level of tax on the income arising in each of the jurisdictions where they operate. More specifically, the GloBE Rules provide for a co-ordinated system of taxation that imposes a top-up tax on profits arising in a jurisdiction whenever the effective tax rate, determined on a jurisdictional basis, is below the minimum rate. These examples illustrate the application of the Model GloBE Rules to certain fact patterns.



For more information:

 ctp.contact@oecd.org

 www.oecd.org/tax/beps

 @OECDtax

 OECD Tax